

APPENDIX A

THE STRATEGIC ENERGY SECURITY CORPORATION:

A LEGISLATIVE INITIATIVE TO PROVIDE MARKET RISK INSURANCE FOR DOMESTIC COAL, OIL SHALE, AND BIOMASS ALTERNATIVE LIQUID FUELS PRODUCERS

Developers of a diverse assortment of alternative liquid fuels manufacturing plants are currently on the sidelines waiting to initiate commercially viable projects, but the risk of market manipulation by OPEC and others is keeping them from committing. The oil market risk insurance program described here provides a self-funding means to overcome a significant barrier to the rapid development of a new and needed domestic liquid fuel industry. By mitigating market risk, project sponsors backed by large pools of private capital will build alternative liquid fuels plants in all 50 U.S. states, strengthening economies, creating millions of jobs, stabilizing fuel prices, and lessening U.S. dependence on foreign oil.

Concept Summary. Congress is encouraged to establish the Strategic Fuels Corporation (“SESC” or the “Corporation”), as a self-funding, self-sustaining government corporation that will administer a new alternative liquid fuels market insurance program (Figure A-1). SESC will provide the following functions: (1) collect insurance premiums from companies that “opt in” to the SESC insurance program; (2) invest net premiums (after administrative costs) in an insurance fund for future payout to program members if and when necessary; (3) facilitate market insurance payments to members if oil prices fall below a defined “Low Trigger Price,” as described below; and (4) administer the collection of “standby” insurance fees, to be levied on imported oil if oil prices fall below the “Low Target Price” and the accumulated investment pool of insurance premiums (including investment returns thereon) is exhausted.

The primary function of the SESC program will be to insure viable markets prices for qualifying alternative liquid fuel plants in the event oil prices fall below a designated “Low Trigger Price” as defined below and in Figure A.2. This will be accomplished by providing insurance payments to insured plant owners if any oil products from their plants sell at prevailing market prices that are less than the Low Trigger Price on a crude oil equivalent basis. By way of example, if an SESC insured plant sells 300,000 barrels of diesel fuel for the crude oil equivalent prevailing market price of \$45 per barrel, the insurance payment to the plant owner would be \$1,500,000, computed as \$50/bbl (Low Trigger Price) less \$45/bbl (sale price of product on crude oil equivalent basis), times 300,000 barrels. Note: if the alternative fuel excise tax credit is operational (see below), the insurance payment is not available until the prevailing market price falls below \$30 per barrel.

Figure A-1

STRATEGIC ENERGY SECURITY CORPORATION FUNCTIONS

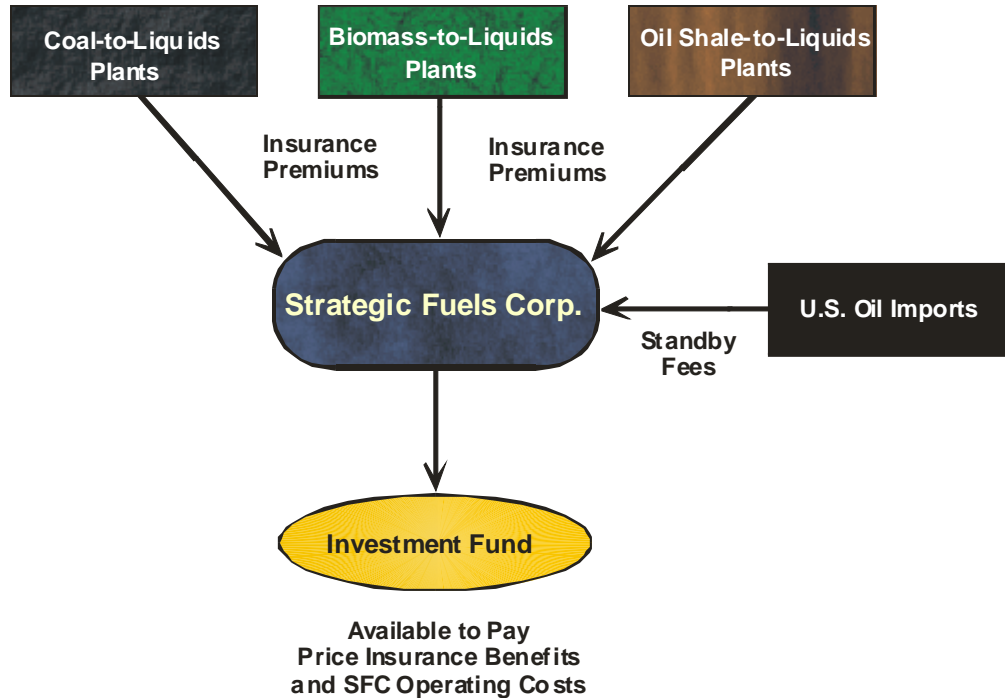

Source: Southern States Energy Board, 2006.

Sources and Use of Proceeds: There will be several sources/levels of funding for this program. Each is described below.

Seed Capital. A one-time appropriation of \$5.0 million provided by Congress to establish, staff and organize the SESC, and to cover ongoing administrative costs for an initial period until adequate member-paid premiums are received that allow the Corporation to become self-funding.

Opt-in Premiums. Plant developers will be required to pay a one-time up-front “Opt-in Premium” to insure a qualifying plant, calculated as two percent of the total capital cost of the plant. For example, to secure SESC insurance for a plant costing \$800 million, the plant owner would pay an Opt-In Premium of \$16 million. For a nominal cost, “a conditional letter of intent to insure” will be issued by SESC for a qualified project, locking in insurance while capital is raised for the project. Once financing is secured, a “commitment fee” portion of the Opt-In Premium will be payable to the SESC, with the balance of this Premium placed in an escrow account. When the plant begins operation, the remaining portion of the Opt-in Premium will be due and released from the escrow account to the SESC. Premium proceeds will be invested in

the SESC insurance fund, available to pay future price insurance benefits, if and when required. Costs to operate the SESC will be drawn from the insurance fund as well.

Operating Premiums. Once an insured plant begins operation, an Operating Premium will become payable, and this fee will be set at two percent of the price of all liquid fuel products sold. Proceeds will be invested in the SESC insurance fund, available to pay future price insurance benefits, if and when required.

Windfall Premiums. These premiums will be paid along with Operating Premiums whenever crude oil prices rise above the High Trigger Price level (assumed to be \$65 for purposes of discussion -- see Figure A-2). Windfall Premium rates will be progressive, based on the level of crude oil prices above the High Trigger Price. They will be computed as follows, using the progressive premium rate table shown in Table A-1.

$$\begin{array}{r}
 \text{Spot Crude Oil Price/bbl} - \$65 \\
 \times \\
 \text{Applicable Windfall Premium Rate} \\
 \times \\
 \text{Barrels Sold During Period} \\
 = \\
 \text{Windfall Premium}
 \end{array}$$

Table A-1 presents the progressive premium rates proposed. The crude oil price ranges in this table are presented for discussion purposes and are subject to adjustment in the authorizing legislation.

**Table A-1
Proposed Windfall Premium Rates**

| Crude Oil Price (2007 \$/bbl) | Windfall Premium Rate |
|----------------------------------|-----------------------------|
| \$65 - \$74.99 | 15% |
| \$75 - \$84.99 | 25% |
| \$85 + | 35% |

Source: Southern States Energy Board, 2006.

Windfall Premiums will be allocated as follows: ¾ of proceeds invested in the SESC insurance fund, available to pay future price insurance benefits, if and when required; and, ¼ of proceeds distributed to LIHEAP, or to another low-income fuel assistance program established to help needy Americans pay for fuel.

National Security Standby Insurance Fees: If oil prices fall below the Low Trigger Price level for more than 30 days, and funds in the SESC insurance pool are exhausted by payment of insurance benefits, a National Security Insurance Fee will then be applied to imported oil (crude and products) to enable ongoing market insurance benefit payments to SESC members. This fee will be assessed on a monthly basis, if and when required, and computed as the amount necessary to enable payment of SESC price insurance benefits for that month. The U.S. currently imports approximately 13 million barrels of oil (crude and products) per day. Consequently, if and when National Security Insurance fees are required, they should not have a significant burden on oil prices. This is evident in the following example. Assume that oil prices fell to \$40 per barrel, the Low Trigger Price was \$50, and the SESC investment pool had been exhausted. Further, assume that there are 1.0 million barrels per day of alternative liquid fuels production covered under SESC price insurance, and 13 million barrels per day of oil being imported. The National Security Standby Insurance Fee would be calculated as follows: $(\text{Low Trigger Price} - \text{Spot Crude Price}/\text{bbl}) \times (\text{Avg. SESC Insured Production per Day}/\text{Avg. Imported Oil per Day})$. Using the assumptions above, this fee would be only \$0.769 /bb, computed as $(\$50 - \$40) \times (1 \text{ MM bpd} / 13 \text{ MM bpd}) = \0.769 per barrel – or about two cents per gallon.

Figure A-2
STRATEGIC ENERGY SECURITY CORPORATION
 High and Low Triggers

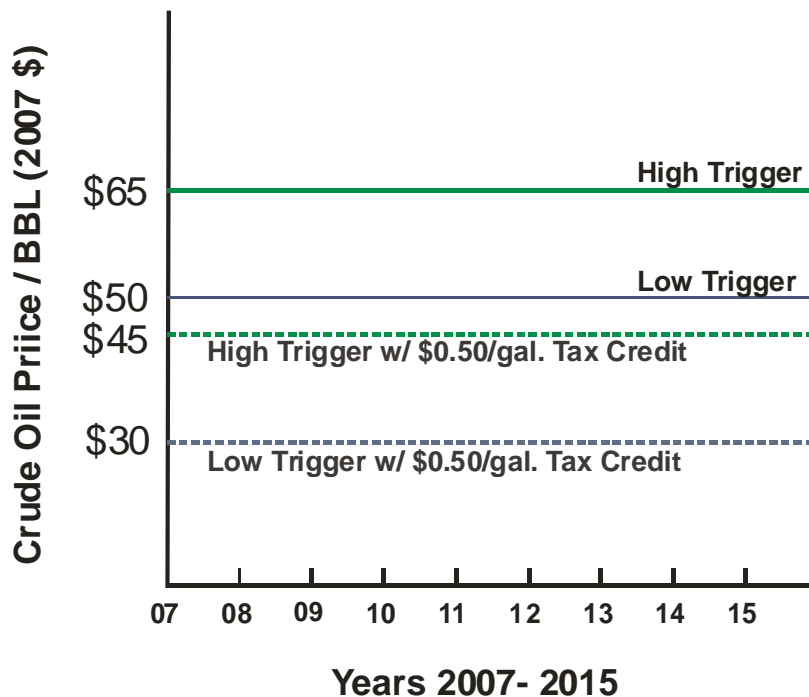

Source: Southern States Energy Board, 2006.

Low Trigger Price: The approximate minimum price needed by an average commercial alternative liquid fuels plants to be viable. This price level is shown as \$50/bbl (2007 dollars) for discussion purposes.

Low Trigger Price With \$0.50/gallon Tax Credit: The approximate minimum price needed by an average commercial alternative liquid fuels plants to be viable, assuming the provision for the current \$0.50 per gallon alternative fuels excise tax credit is extended and is in effect (see discussion below). This price level is shown as \$30/bbl (2007 dollars) for discussion purposes. As background, the Safe, Accountable, Flexible, Efficient Transportation Equity Act: A Legacy for Users, SAFETEA-LU 2005 extension, provides a \$0.50 per gallon excise tax credit for certain alternative liquid fuels, including coal-to-liquids and biomass-to-liquids fuel products. This translates to an additional \$21.00 per barrel of added revenues for qualifying producers. The excise credit expires in 2009. If extended, which is strongly encouraged, it would have the effect of lowering the Low Trigger Price by about \$20 per barrel.

High Trigger Price: The High Trigger price would be based on a \$15 per barrel premium above the low trigger price. This is the price at which Windfall Premiums are triggered, shown as \$65/bbl (2007 dollars) for discussion purposes.

High Trigger Price With \$0.50/gallon Tax Credit: The price at which Windfall Premiums are triggered, assuming the provision for the current \$0.50 per gallon alternative fuels excise tax credit is extended and is in effect (see discussion above). This price level is shown as \$45/bbl (2007 dollars) for discussion purposes.

Full or Partial Insurance: Plant developers may choose to insure the market price for all or only a portion of plant output. Premium charges will be adjusted on a prorate basis. If, for example, a long-term contract is established for 60 percent of the output of a plant, the developer can insure the remaining 40 percent of production with SESC.

Insurance Benefit Payment Schedule: If and when necessary, insurance benefits will be paid on a monthly basis.

Inflation: Low and High Trigger Prices will be adjusted on a quarterly basis by suitable escalation formulas to be established.

Insurance Term. A plant can participate in the SESC insurance program for the first 10 years of its operation life.

Program Term (Sunset and Winding Up). The SESC will automatically dissolve at midnight on December 31, 2025. Money remaining in the SESC investment fund will be distributed: ½ to insurance program participants on the basis of their net premiums paid (premiums paid less insurance benefits received), with distribution computed with consideration given to the time value of money; and ½ distributed to

LIHEAP, or to another low-income fuel assistance program established to help needy Americans pay for fuel.

Federal Loan Guarantee Recipients. It is suggested that alternative fuels plant developers utilizing federal loan guarantees be required to purchase insurance from SESC.

Successes to Model

Sasol: This South African company single-handedly provides for almost 30 percent of the countries transportation fuel requirements by converting coal to liquids – see the discussion in Section IV.B.1. The South African Government, which facilitated the establishment of Sasol through the Industrial Development Corporation, did so by providing loan guarantees and a floor price mechanism. A requirement was also put in place for Sasol to repay the government if crude oil prices exceeded a pre-determined level, which occurred. All government loans and support were fully repaid in due time and there was no net cost to the taxpayer, and no support has been in place for several decades. The economic and multiplier effects of having such facilities, and the national security benefits, are substantial. Sasol is now a private sector company which is very profitable, it has produced more than 1.5 billion barrels of fuel from coal since its inception in 1950, and markets in excess of 200 chemical products internationally. Sasol shares are traded at various stock exchanges around the world, including the NYSE.

Alberta, Canada Tar Sands: The following statement made by Senator Orrin Hatch in October 2005 is instructive. “Alberta [Canada] is now second only to Saudi Arabia in proven oil reserves and ninth in the world in annual oil production. This is owing mostly to their successful development of oil sands. In Alberta, you have dozens of major oil companies, using a variety of technologies and recovery methods, going after very different types of oil sands resources, and in almost every case doing so [now] for less than \$20 a barrel, including during their very tough winters. It is a gigantic success story, and it began with Alberta’s government deciding to promote the development of this resource and not giving up.”

OPIC: The Overseas Private Investment Corporation (OPIC) was formed by Congress in 1971 as a development agency of the U.S. government, providing political risk insurance and other incentives for American businesses to make foreign direct investment in designated high-risk countries. Through insurance premiums and other user fees and charges, OPIC has operated successfully for decades as a self-sustaining U.S. Government corporation, assisting private industry to reduce risk to levels that stimulate investments in targeted countries. In a very similar function, SESC will reduce risk and stimulate investment in a crucial new domestic industry, the alternative liquid fuels industry.

APPENDIX B: COAL RESOURCES:

RETHINKING U.S. COAL RESERVES AND RESOURCES

Introduction

How much U.S. coal is available for recovery in the near, intermediate and long-term is important knowledge for decision makers as they attempt to guide our country toward energy security and independence. America is endowed with the largest coal reserves in the world. Recoverable reserves are estimated to be 270 billion tons by the Energy Information Administration (EIA). In 2005 the U.S. produced 1.13 billion tons of coal, second only to China. Based on EIA's 270 billion ton estimate, America has more than 200 years of coal at today's production rate. Even if production were to be doubled, the recoverable reserves would last for more than a century.

This chapter presents an overview of U.S. coal reserves and resources. Reserves and resources are discussed together because resources are the deposits of coal in such a condition that economic extraction is currently or may become feasible. Reserves are a special subset of resources that can be economically mined at the time of determination. The US has large amounts of both reserves and resources. This report will describe the importance of these resource-reserve categories.

It also offers evidence that the widely referenced EIA reserve estimates understated America's true coal potential. Decision makers frequently refer to the EIA 270 billion ton recoverable reserve estimate as being America's coal endowment but the EIA total coal resource for the U.S. is nearly 4 trillion tons and the Demonstrated Reserve Base (DRB) is nearly 500 billion tons. Clearly the U.S. endowment of coal is enormous. In fact there is evidence that the 500 billion ton DRB better approximates U.S. coal resources that will ultimately be recovered when advancements in technology, coal field growth, new discoveries, and other dynamics are taken into account. This report will demonstrate this evidence.

The purpose of this report is to provide a clear picture of the magnitude of the U.S. coal endowment. Methods and limitations to EIA and USGS approaches to coal reserve estimation are discussed and recommendations are made to improve these methods.

As part of the research for this report, a questionnaire was sent to coal geologists at state geological surveys or other state agencies that assess coal resources, to gather current expert knowledge of each state's coal resources. The specific goal of this survey was to evaluate EIA's DRB versus state Identified resources. Officials of the USGS and the EIA were also interviewed to gain their perspective. Results from this survey are discussed in "State-by-State Coal Resource Survey Results." The survey questionnaire, and complete survey responses, are presented in Appendix 1 to this report.

Inspiration From China

China has not only recognized the strategic significance of its coal resources, it is acting aggressively to realize the full potential of this low cost, multi-use fuel and feedstock. China is utilizing coal as a primary fuel source for the production of electricity and steel. They have

also taken the lead in the world with regard to coal-to-liquids and coal gasification initiatives. Take a look at Chinese coal production growth between 2000 and 2004 in Figure 1 below. This new world competitor plans to add as much as another billion tons of annual coal production by 2020.¹

Figure 1.

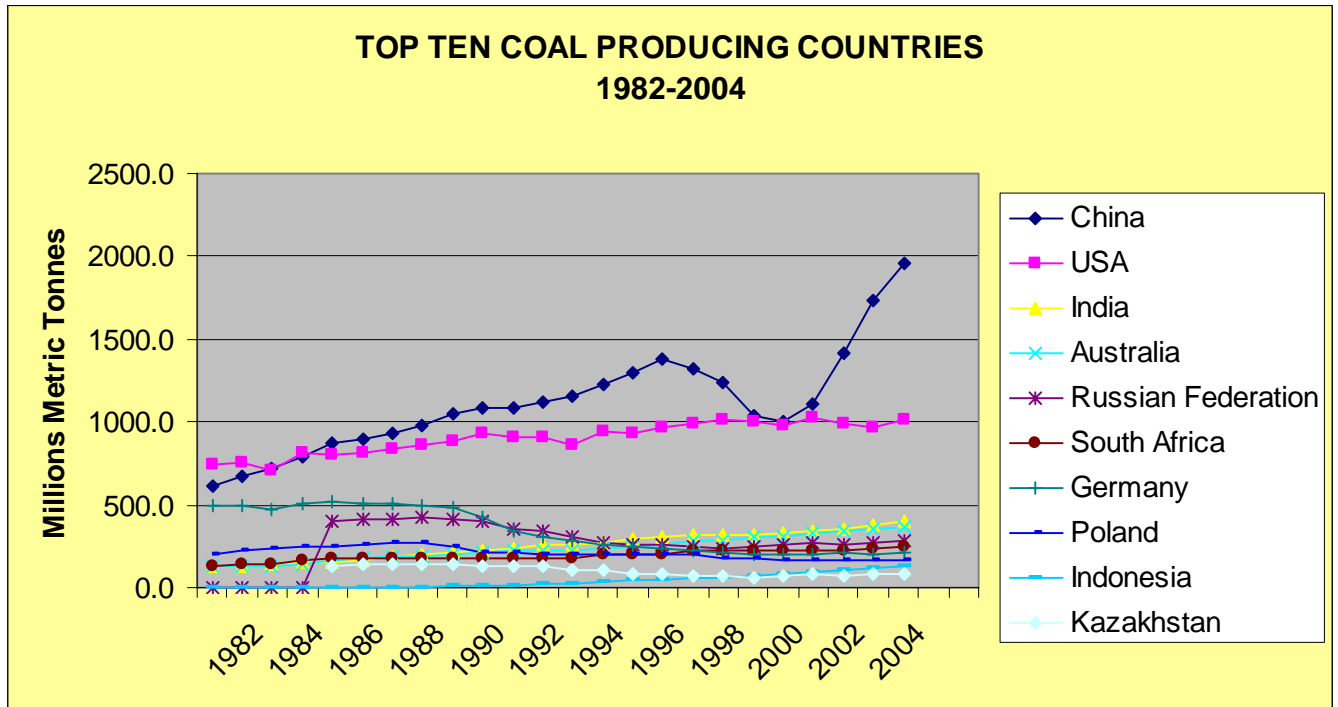

Source: “BP Statistical Review of World Energy 2005,”
<http://www.bp.com/genericsection.do?categoryId=92&contentId=7005893>, June 14, 2005

DOE EIA Coal Reserves and Resources Estimates

The coal fields of the U.S. are vast, diverse, and well distributed across the country. The DOE reports coal deposits of one or more coal ranks (bituminous, subbituminous, lignite and anthracite) in thirty-three states, as shown in the map of major U.S. coal fields (Figure 2) below.

Figure 2

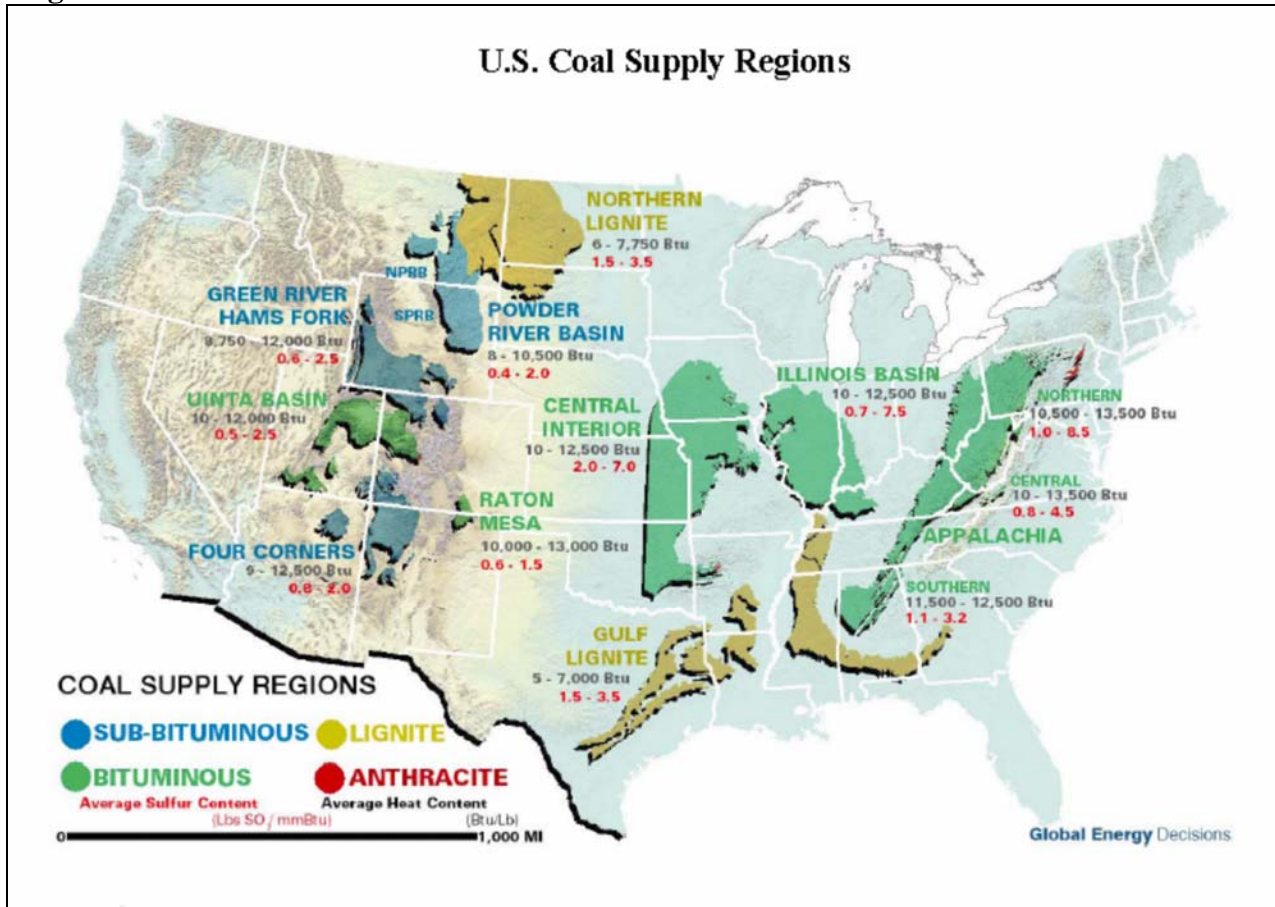

Source: The National Coal Council, "Coal: America's Energy Future," May 2006, Pg. 99

Below is a summary of current U.S. coal reserve/resource estimates by category, published by the DOE EIA. These estimates are discussed in some detail throughout this chapter.

DOE EIA COAL RESERVE/RESOURCE ESTIMATES (2004)

Estimated Recoverable Reserves: 267.3 billion tons²

Demonstrated Reserve Base: 494.4 billion tons³

Identified Resources: 1,730.9 billion tons⁴

Total Resources: 3,968.3 billion tons⁵

In general terms, Estimated Recoverable Reserves (ERR) are held to be the portion of the Demonstrated Reserve Base that will be recovered by mining. The Demonstrated Reserve Base (DRB) is comprised of "in-place" coal that meets certain criteria of measurement reliability, and is found within defined depths and in coalbed thicknesses considered technologically minable at

the time of determination. An estimate is then made as to what percentage of the demonstrated base are accessible and economically recoverable by current mining methods under existing regulatory limits. EIA estimates that approximately 17% of the DRB is inaccessible for mining, and that 34% of the accessible portion would be unrecovered or lost during mining, leaving 54% of the DRB as potentially recoverable. This equates to 268 billion tons of recoverable coal using the recent 494 billion ton DRB estimate.

The “Coal Reserve and Resource Estimate Methodologies” section of this chapter contains definitions and descriptions of primary coal reserve measurement classifications, terms, and guidelines. Subsequent sections, “Limitations of DOE EIA Estimates” and “State-by-State Coal Resource Survey Results” present additional data, analysis and observations about the EIA’s coal reserve projections and methodology.

Table 1 (below) shows EIA 2004 figures for “Estimated Recoverable Reserve” and “Demonstrated Reserve Base” estimates by state and mining method. These numbers are presented for underground and surface mineable coal, and as combined totals.

Table 1. Estimated Recoverable Reserves, and Demonstrated Reserve Base by Mining Method, 2004 (Million Short Tons) ⁶

| Coal Resource By State | Underground Mineable Coal | | Surface Mineable Coal | | Total | |
|------------------------|--------------------------------|---------------------------|--------------------------------|---------------------------|--------------------------------|---------------------------|
| | Estimated Recoverable Reserves | Demonstrated Reserve Base | Estimated Recoverable Reserves | Demonstrated Reserve Base | Estimated Recoverable Reserves | Demonstrated Reserve Base |
| Alabama | 521 | 1,034 | 2,285 | 3,208 | 2,806 | 4,242 |
| Alaska | 2,745 | 5,423 | 545 | 689 | 3,291 | 6,112 |
| Arizona | - | - | 5 | 7 | 5 | 7 |
| Arkansas | 127 | 272 | 101 | 144 | 228 | 417 |
| Colorado | 6,050 | 11,529 | 3,748 | 4,764 | 9,798 | 16,293 |
| Georgia | 1 | 2 | 1 | 2 | 2 | 4 |
| Idaho | 2 | 4 | - | - | 2 | 4 |
| Illinois | 27,944 | 87,972 | 10,075 | 16,557 | 38,019 | 104,529 |
| Indiana | 3,630 | 8,764 | 451 | 771 | 4,080 | 9,534 |
| Iowa | 807 | 1,732 | 320 | 457 | 1,127 | 2,189 |
| Kansas | - | - | 681 | 973 | 681 | 973 |
| Kentucky Total | 7,488 | 17,202 | 7,516 | 13,023 | 15,004 | 30,225 |
| Eastern | 716 | 1,282 | 5,244 | 9,389 | 5,960 | 10,671 |
| Western | 6,772 | 15,920 | 2,273 | 3,634 | 9,044 | 19,554 |
| Louisiana | - | - | 316 | 427 | 316 | 427 |
| Maryland | 320 | 584 | 46 | 67 | 366 | 652 |
| Michigan | 55 | 123 | 3 | 5 | 59 | 128 |
| Mississippi | - | - | - | - | - | - |
| Missouri | 689 | 1,479 | 3,158 | 4,511 | 3,847 | 5,990 |
| Montana | 35,922 | 70,958 | 39,067 | 48,322 | 74,989 | 119,280 |
| New Mexico | 2,848 | 6,171 | 4,086 | 6,001 | 6,934 | 12,172 |
| North Carolina | 5 | 11 | - | - | 5 | 11 |

| | | | | | | |
|--|----------------|----------------|----------------|----------------|----------------|----------------|
| North Dakota | - | - | 6,935 | 9,090 | 6,935 | 9,090 |
| Ohio | 7,733 | 17,577 | 3,774 | 5,765 | 11,507 | 23,342 |
| Oklahoma | 574 | 1,232 | 227 | 325 | 801 | 1,557 |
| Oregon | 7 | 15 | 2 | 3 | 9 | 17 |
| Pennsylvania Total | 10,768 | 23,330 | 1,055 | 4,267 | 11,822 | 27,597 |
| Anthracite | 340 | 3,844 | 420 | 3,356 | 760 | 7,200 |
| Bituminous | 10,428 | 19,486 | 635 | 911 | 11,062 | 20,397 |
| South Dakota | - | - | 277 | 366 | 277 | 366 |
| Tennessee | 281 | 513 | 180 | 266 | 462 | 779 |
| Texas | - | - | 9,578 | 12,442 | 9,578 | 12,442 |
| Utah | 2,538 | 5,177 | 212 | 268 | 2,750 | 5,445 |
| Virginia | 653 | 1,163 | 369 | 576 | 1,022 | 1,740 |
| Washington | 674 | 1,332 | 7 | 8 | 681 | 1,341 |
| West Virginia | 15,673 | 29,366 | 2,431 | 3,854 | 18,104 | 33,220 |
| Wyoming | 22,950 | 42,501 | 18,853 | 21,824 | 41,804 | 64,325 |
| | | | | | | |
| U.S. Total | 151,007 | 335,468 | 116,305 | 158,982 | 267,312 | 494,450 |
| | | | | | | |
| W = Withheld to avoid disclosure of individual company data. | | | | | | |
| NA = This estimated value is not available due to insufficient data or inadequate data/model performance. | | | | | | |
| Note: · Recoverable coal reserves at producing mines represent the quantity of coal that can be recovered (i.e. mined) from existing coal reserves at reporting mines. EIA's estimated recoverable reserves include the coal in the demonstrated reserve base considered recoverable after excluding coal estimated to be unavailable due to land use restrictions or currently economically unattractive for mining, and after applying assumed mining recovery rates; see "Coal Reserve and Resource Estimate Methodologies" for criteria. The effective date for the demonstrated reserve base, as customarily worded, is "Remaining as of January 1, 2005." These data are contemporaneous with the Recoverable reserves at Producing Mines, customarily presented as of the end of the past year's mining, that is in this case, December 31, 2004. The demonstrated reserve base includes publicly available data on coal mapped to measured and indicated degrees of accuracy and found at depths and in coalbed thicknesses considered technologically minable at the time of determinations; see "Coal Reserve and Resource Estimate Methodologies" for criteria. Excludes silt, culm, refuse bank, slurry dam, and dredge operations except for Pennsylvania anthracite. Excludes mines producing less than 10,000 short tons, which are not required to provide data and refuse recovery. | | | | | | |
| Data Source: Energy Information Administration Form EIA-7A, "Coal Production Report," and U.S. Department of Labor, Mine Safety and Health Administration, Form 7000-2, "Quarterly Mine Employment and Coal Production Report," and EIA estimates. http://www.eia.doe.gov/cneaf/coal/page/acr/table15.html | | | | | | |

U.S. coal resources are widely distributed geographically. Approximately 21% of U.S. coal resource lies in the Appalachian region; 32% in the Interior region; and 47% in the Western region (see the Figure 3 region map below). Note that *Eastern* Kentucky is included in the Appalachian region, while *Western* Kentucky (on the Eastern edge of the Illinois Basin) is counted in the Interior region.

U.S. deposits are found in four major types, also known as "rank". Anthracite comprises approximately 1.5% of the DRB; bituminous 53%; subbituminous 37%; and lignite 8.5%. The majority of our reserve base is recoverable by underground methods (about 335 billion tons, or 68%), with surface mineable measures making up the rest (158 billion tons or 32%).

The following map (Figure 3) highlights the three coal regions often used to describe where coal occurs and production originates.

Figure 3. U.S. Coal Regions

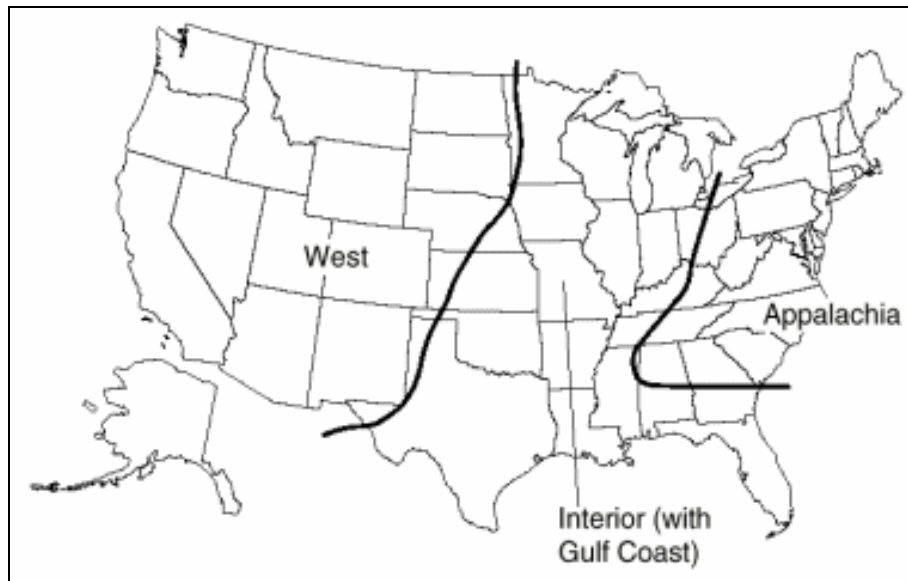

Source: Energy Information Administration

The EIA’s current Estimated Recoverable Reserve (EER) projection of approximately 270 billion tons is likely the most frequently cited measure of “U.S. coal reserves.” The ERR is a calculated percentage of the Demonstrated Reserve Base (DRB), currently estimated to be about 54% of the DRB average for the entire U.S.

As previously noted, one objective of this reserve analysis is to determine whether the EER represents an accurate measure of the nation’s coal potential, as many decision makers believe. The state coal survey conducted for this report clearly indicates that the 2004 EIA estimates are viewed to be understated (see “State-by-State Coal Resource Survey Results”). The report section entitled “Limitations of DOE EIA Estimates” offers analysis and insight as to why the ERR estimates fall short of providing a good measure of ultimately recoverable U.S. coal reserves.

Using the EIA estimates, the U.S. is endowed with almost two times the coal resources of the Russian Federation, the second largest international reserve holder. World coal reserve estimates are presented by country in Table 2 (below). One interesting statistic is that China has only about half of the coal resources of the U.S., yet they produced approximately 2.2 billion tons in 2005 (double U.S. production levels), and have committed to increase output to as much as 3.0 billion annual tons by 2020.

Note that the estimates in Table 2 (below) were compiled by the World Coal Council and are in metric tons. To convert to U.S. tons, multiply by 1.10229.

Table 2

| Coal: Proved Reserves at End of 2004 ⁷ (million metric tonnes) | | | | | |
|--|---------------------------|---------------------------|---------------|----------------|---|
| Table in millions of metric tonnes. | Anthracite and bituminous | Subbituminous and Lignite | Total | Share of total | Reserve-to-Production (R/P) ratio in years of reserves. |
| USA | 111338 | 135305 | 246643 | 27.10% | 245 |
| Russian Federation | 49088 | 107922 | 157010 | 17.30% | * |
| China | 62200 | 52300 | 114500 | 12.60% | 59 |
| India | 90085 | 2360 | 92445 | 10.20% | 229 |
| Australia | 38600 | 39900 | 78500 | 8.60% | 215 |
| South Africa | 48750 | - | 48750 | 5.40% | 201 |
| Ukraine | 16274 | 17879 | 34153 | 3.80% | 424 |
| Kazakhstan | 28151 | 3128 | 31279 | 3.40% | 360 |
| Other Europe & Eurasia | 1529 | 21944 | 23473 | 2.60% | 341 |
| Poland | 14000 | - | 14000 | 1.50% | 87 |
| Brazil | - | 10113 | 10113 | 1.10% | * |
| Germany | 183 | 6556 | 6739 | 0.70% | 32 |
| Colombia | 6230 | 381 | 6611 | 0.70% | 120 |
| Canada | 3471 | 3107 | 6578 | 0.70% | 100 |
| Czech Republic | 2094 | 3458 | 5552 | 0.60% | 90 |
| Indonesia | 740 | 4228 | 4968 | 0.50% | 38 |
| Turkey | 278 | 3908 | 4186 | 0.50% | 87 |
| Greece | - | 3900 | 3900 | 0.40% | 55 |
| Hungary | 198 | 3159 | 3357 | 0.40% | 240 |
| Pakistan | - | 3050 | 3050 | 0.30% | * |
| Other S. & Cent. America | 992 | 1698 | 2690 | 0.30% | * |
| Bulgaria | 4 | 2183 | 2187 | 0.20% | 84 |
| Thailand | - | 1354 | 1354 | 0.10% | 67 |
| Mexico | 860 | 351 | 1211 | 0.10% | 135 |
| Other Africa | 910 | 174 | 1084 | 0.10% | 490 |
| North Korea | 300 | 300 | 600 | 0.10% | 21 |
| New Zealand | 33 | 538 | 571 | 0.10% | 115 |
| Spain | 200 | 330 | 530 | 0.10% | 26 |
| Zimbabwe | 502 | - | 502 | 0.10% | 154 |
| Romania | 22 | 472 | 494 | 0.10% | 16 |
| Venezuela | 479 | - | 479 | 0.10% | 53 |
| Middle East | 419 | - | 419 | ♦ | 399 |
| Japan | 359 | - | 359 | ♦ | 268 |
| Other Asia Pacific | 97 | 215 | 312 | ♦ | 34 |

| | | | | | |
|--|-----|----|-----|---|------------------------------|
| United Kingdom | 220 | - | 220 | ♦ | 9 |
| Vietnam | 150 | - | 150 | ♦ | 6 |
| South Korea | - | 80 | 80 | ♦ | 25 |
| France | 15 | - | 15 | ♦ | 17 |
| * More than 500 years | | | | | Source: World Energy Council |
| ♦ Less than 0.05% | | | | | |
| Notes: | | | | | |
| Proved reserves of coal - Generally taken to be those quantities that geological and engineering information indicates with reasonable certainty can be recovered in the future from known deposits under existing economic and operating conditions. | | | | | |
| Reserves/Production (R/P) ratio - If the reserves remaining at the end of the year are divided by the production in that year, the result is the length of time that those remaining reserves would last if production were to continue at that level. | | | | | |
| | | | | | |

Note: 1 metric tonne = 1.10229 U.S. tons and 1 U.S. ton = 0.9072 metric tonnes.

Coal Reserve and Resource Estimate Methodologies

In order to use coal resource estimates for decision making, it is important to understand the methodologies and assumptions that underlie them.

Coal resource evaluations and estimation have been conducted by state and federal geological surveys periodically since the beginning of the industrial revolution. Studies are typically sponsored by policy makers in times of national need, such as the Arab Oil Embargo of the early 1970's. This has resulted in new resource estimates every 25 to 50 years.

The U.S. Bureau of Mines (USBOM) and the U.S. Geological Survey (USGS) played central roles in coal resource estimates as facilitators of congressionally funded programs for geologic mapping in the nation, and as technical advisors to the states. In 1983, the USGS published guidelines and accepted methodology for calculating coal resources in Coal Resources Classification System of the U.S. Geological Survey, also known as USGS Circular 891.⁸ These methods are almost uniformly used by practitioners in the U.S., including the DOE EIA and the state geological surveys. They are described in some detail below.

Current Coal Resource Classification System.

The pyramid graphic below (Figure 4) presents a visual characterization of how coal resources are classified in the U.S. From top to bottom, the pyramid generally represents reserves/resource estimates by diminishing degree of confidence in data reliability and mineability characteristics. The top two categories, "Recoverable Reserves at Active Mine" and "Estimated Recoverable Reserves," are estimates of tonnage that is available to be recovered by current mining practices. The lower categories are estimates of "in-place" coal resources, before applying a recovery factor.

The Figure 4 resource pyramid is based on older data. Although dated, the graphic has been included to introduce the current approach to classifying coal reserve and resources.

Figure 4. Delineation of U.S. Coal Resources and Reserves (billions of short tons)⁹

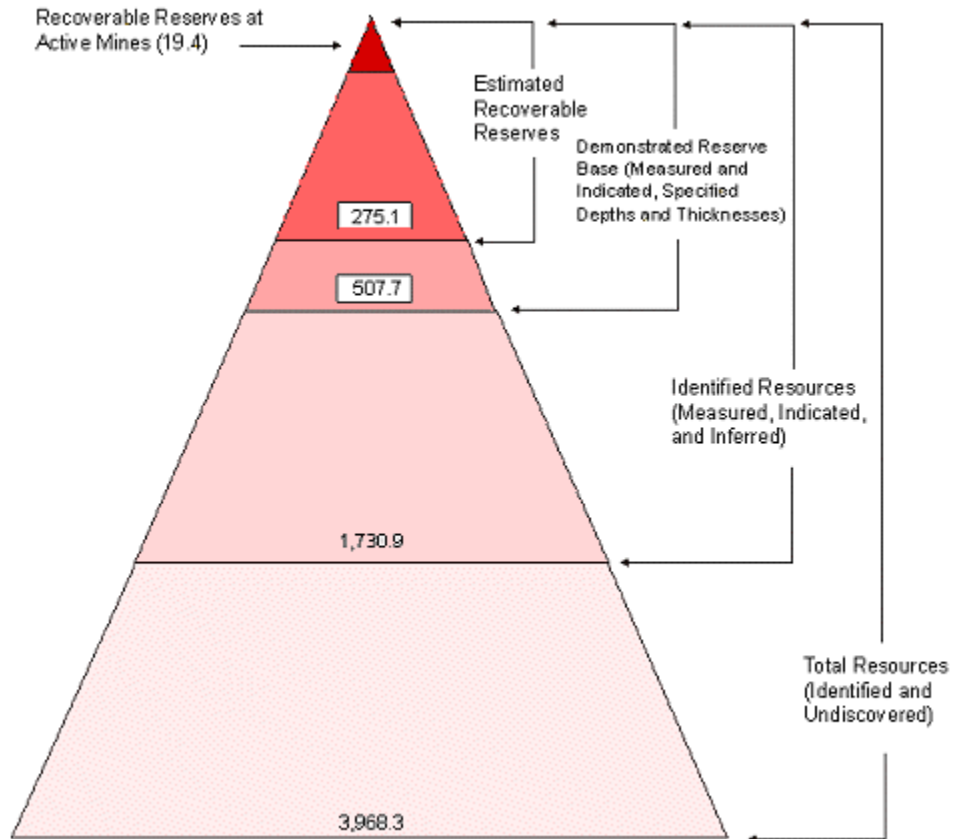

Notes: Resources and reserves data are in billion short tons. Darker shading in the diagram corresponds to greater relative data reliability. The estimated recoverable reserves depicted near the top of the diagram assume that the 19 billion short tons of recoverable reserves at active mines reported by mine operators to the Energy Information Administration (EIA) are part of the same body of resource data. This diagram portrays the theoretical relationships of data magnitude and reliability among coal resource data. All numbers are subject to revision with changes in knowledge of coal resource data.

Data Sources: The DRB estimate was compiled by the EIA as of January 1, 1997. Estimated recoverable reserves were compiled in EIA's Coal Reserves Data Base (CRDB) program. Recoverable reserves at active mines were reported in EIA's Coal Industry Annual, 1996. Identified resources and total resources are estimates as of January 1, 1974, compiled and published by the U.S. Geological Survey in Coal Resources of the United States, January 1, 1974.

[This Space Left Blank Intentionally]

Definitions of Terms.^{10 11}

Recoverable Reserves at Producing (Active) Mines: The amount of in situ coal that can be recovered by mining existing reserves at mines reporting on Form EIA-7A. This reserve category is not especially meaningful.

Estimated Recoverable Reserves: This category is calculated from the Demonstrated Reserve Base (the DRB as defined below). A recovery factor is applied to the DRB to estimate recoverable reserves. The recovery factor is derived from actual mining practices in the active mining district. Estimated recoverable reserves include the coal in the “in-place” demonstrated reserve base that is considered to be accessible to the mining industry, technologically mineable, and can be recovered by the prevailing mining methods for a region. Accessibility factors relate to limitations to mining due to regulatory and land use constraints. Technological limitations may be regulatory (required mine buffers) or other physical barriers to mining. Recovery percentages are estimated according to mining method. Surface mining regions have higher recovery rates, longwall mines have intermediate rates, and conventional and continuous underground mining areas have the lowest recovery rates.

The ERR recovery rate averages 54 percent of the DRB for the nation, with a range between 36 and 77 percent for individual states. Table 3, presented later in this chapter, sets forth DOE’s estimated average recovery rates for each state.

Demonstrated Reserve Base: Represents that portion of identified coal resources from which reserves are calculated. A collective term for the sum of coal in both measured and indicated resource categories of reliability which represents 100 percent of the coal in these categories in place as of a certain date. Includes beds of bituminous coal and anthracite 28 inches or more thick and beds of subbituminous coal 60 inches or more thick that occur at depths to 1,000 feet. This includes beds of lignite 60 inches or more thick that can be surface mined. Includes also thinner and/or deeper beds that presently are being mined or for which there is evidence that they could be mined commercially at this time.

The demonstrated reserve base includes publicly available data on coal mapped to measured and indicated degrees of certainty and found at depths and in coalbed thickness considered technologically minable at the time of determination. In most cases, the DRB begins with Identified Resources and then excludes coal in certain resource categories. For example, the DRB includes only bituminous coal greater than 28 in thick (subbituminous and lignite greater than 5 feet that is surface mineable). DRB coal must be less than 1000 ft in depth for bituminous and subbituminous coals, or 500 ft for lignite. Only coal within $\frac{3}{4}$ mile of a thickness measurement is included in the DRB. It is also periodically reduced to account for historical mining production or increased as a result of additions of new data or mining activity in areas outside the DRB. In cases where state estimates used different classifications than Circular 891 or lack certain categories (e.g., not all estimates include overburden data), the EIA devised methods for estimating these categories. The current DRB is about 15% of total Identified Resources.

Identified Resources: Specific bodies of coal whose location, rank, quality, and quantity are known from geologic evidence supported by engineering measurements. Included are beds of bituminous coal and anthracite 14 inches or more thick and beds of subbituminous coal and lignite 30 inches or more thick that occur at depths to 6,000 feet and whose existence and

quantity have been delineated within specified degrees of geologic assurance as measured, indicated, and inferred (see definitions below).

USGS Circular 891 specifies the criteria for subdividing coal resources on the basis of coal rank, total coal thickness, overburden thickness, and confidence of the estimate. Confidence of the estimate is based on proximity to coal thickness measurements (from outcrops, drill holes, logged wells and mine measurements), and is determined by scribing circles of increasing diameter around thickness locations used for preparing the estimate. This categorization is especially significant, because recoverable coal in the Identified Resources classification may be excluded from the DRB estimate due to wide spacing of measurement data (see Figure 5). This is perhaps one of the biggest shortcomings of the EIA classification system.

Undiscovered Resources: Unspecified bodies of coal surmised to exist on the basis of broad geologic knowledge and theory but not specifically drilled or measured in the field. Undiscovered resources include beds of bituminous coal and anthracite 14 inches or more thick and beds of subbituminous coal and lignite 30 inches or more thick that are presumed to occur in unmapped and unexplored areas to depths of 6,000 feet. The speculative and hypothetical resource categories (defined below) comprise undiscovered resources. In remote areas in the U.S. such as Alaska huge amounts of coal in this category are known to exist.

Hypothetical Resources: Undiscovered coal resources in beds that may reasonably be expected to exist in known mining districts under known geologic conditions. In general, hypothetical resources are in broad areas of coalfields where points of observation are absent and evidence is from distant outcrops, drill holes, or wells. Exploration that confirms their existence and better defines their quantity and quality would permit their reclassification as identified or demonstrated resources. Quantitative estimates are based on a broad knowledge of the geologic character of a coal bed or region. Measurements of coal thickness are more than 6 miles apart. The assumption of continuity of coal bed is supported by geologic models not direct measurements.

Speculative Resources: Undiscovered coal in beds that may occur either in known types of deposits in a favorable geologic setting where no discoveries have been made, or in deposits that remain to be recognized. Exploration that confirms their existence and better defines their quantity and quality would permit their reclassification as identified resources.

The following Figure 5 diagrams how the elemental measurements of coal reserve certainty, “measure resources,” “indicated resources,” and “inferred resources,” are applied in the coal fields. These three measurements form the foundation of current coal reserve and resource estimation in the U.S. Definitions of each measurement follow Figure 5.

[This Space Left Blank intentionally]

Figure 5. Measured, Indicated and Inferred Areas Around a Coal Observation/Exploration Point

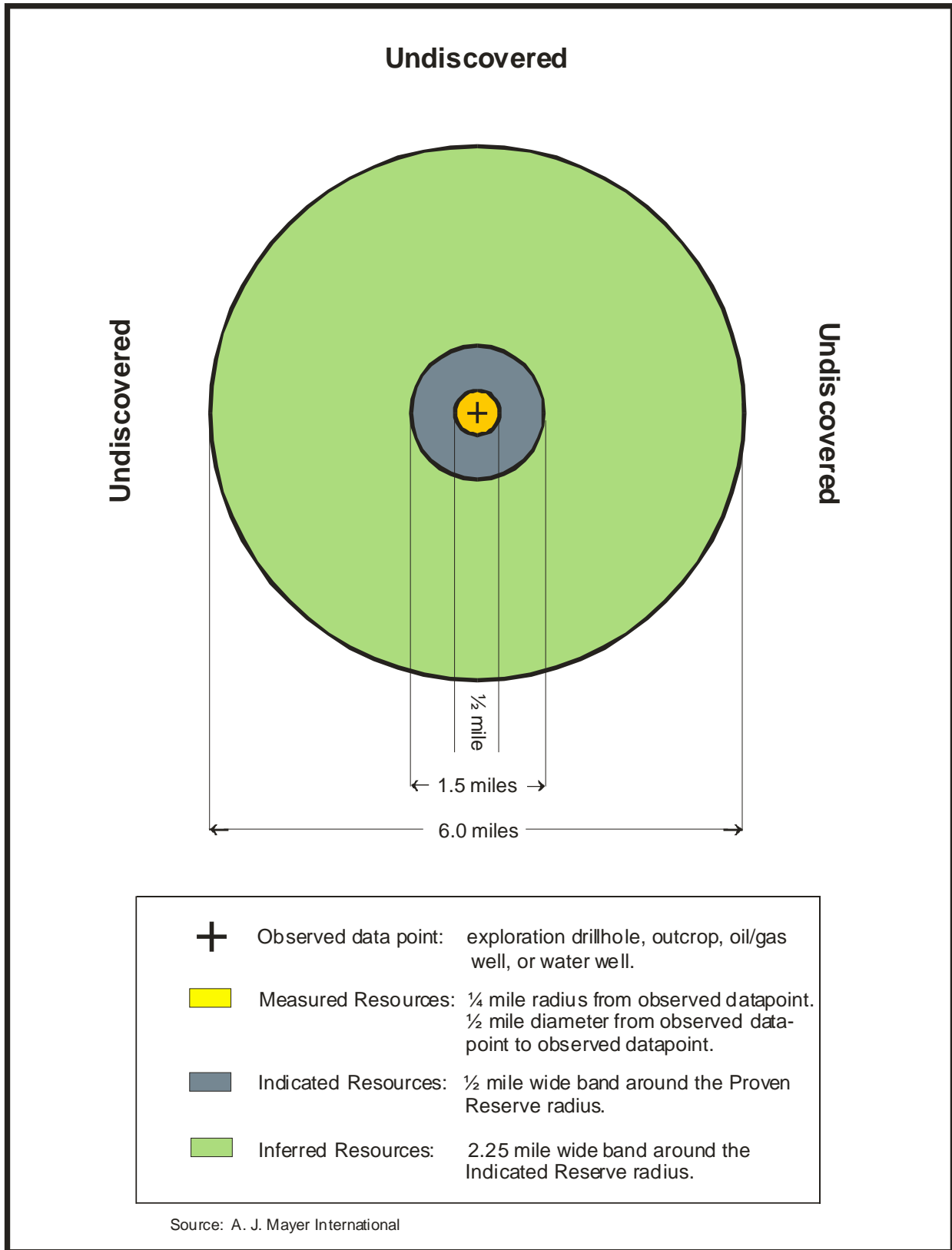

Measured Resources: Coal for which estimates of the rank, quality, and quantity have been computed within a high degree of geologic assurance, from sample analyses and measurements from closely spaced and geologically well known sample sites. Measured resources are computed from dimensions revealed in outcrops, trenches, mine workings, and drill holes. The points of observation and measurement are so closely spaced and the thickness and extent of coals are so well defined that (for older estimates) the tonnage was judged to be accurate within 20 percent of true tonnage (statistical measures of error are no longer considered reliable for most measured resources). Although the spacing of the points of observation necessary to demonstrate continuity of the coal differs from region to region according to the character of the coalbeds, the points of observation are not greater than 0.5 mile apart. Measured coal is projected to extend as a 0.25-mile-wide arc from the outcrop or points of measurement.

Indicated Resources: Coal for which estimates of the rank, quality, and quantity have been computed partly from sample analyses and measurements and partly from reasonable geologic projections. Indicated resources are computed partly from specified measurements and partly from projection of visible data for a reasonable distance on the basis of geologic evidence. The points of observation are 0.5 to 1.5 miles apart. Indicated coal is projected to extend as a 0.5-mile-wide belt that lies more than 0.25 miles from the outcrop or points of observation or measurement.

Inferred Resources: Coal in unexplored extensions of demonstrated resources for which estimates of the quality and size are based on geologic evidence and projection. Quantitative estimates are based largely on broad knowledge of the geologic character of the bed or region and where few measurements of bed thickness are available. The estimates are based primarily on an assumed continuation from demonstrated coal for which there is geologic evidence. The points of observation are 1.5 to 6 miles apart. Inferred coal is projected to extend as a 2.25-mile-wide belt that lies more than 0.75 miles from the outcrop or points of observation or measurement.

Regional Update Studies

There are a number of studies that have attempted to take U.S. coal reserve and resources classification and estimation to a higher level. Here are brief descriptions of some of the major initiatives.

Coal Availability Studies (CAS): In 1988, the USGS and cooperating state geological surveys began a program that is assessing how much of Identified Resources would be available to the coal industry for mining. These studies take into account regulatory considerations that restrict mining (e.g., public lands, streams, or oil and gas wells) as well as technological issues that impede mining such as coal too thin to be mined, mine barriers, or faulted areas. Coal availability estimates have not been produced for the entire nation, but studies to date suggest that as much as 50 percent of Identified Resources may not be available for mining in some regions.

Coal Recoverability Studies (CRS): A program was developed at the former U.S. Bureau of Mines, currently conducted by the USGS, that takes the results of coal availability studies and applies an engineering assessment of mineability and recoverability. Resource

calculations in this method differ from others previously mentioned in that they include rock partings in the original resource calculation, and subsequently estimate the coal recovery percent according to projected mine method and washability characteristics. Mine blocks and transportation routes are simulated by the program. These results vary widely, but depending on the economic constraints used, suggest that only 5 to 25 percent of Identified Resources are recoverable. These studies have an advantage over the assumptions made in the ERR, because they are based primarily on site-specific data.

National Update Studies

National Coal Resource Assessment (NCRA): The USGS began a program in 1995 that prepares resource assessment of coal beds for entire coal basins. The methodology used is that of Circular 891, except that all the data were compiled in computer format using Geographic Information System (GIS) software. Data from adjoining states were compiled into a single assessment. Because of time constraints, these studies were only conducted for the major coal producing beds, and therefore cannot be easily compared to the DRB estimates that are aggregated for all beds. Some of the NCRA assessments have been updated using coal availability and recoverability criteria, yielding basin-wide estimates of economically recoverable coal resources.

Ongoing USGS Work: The USGS has embarked on a systematic inventory of the U.S. coal reserve base, representing a marked departure from previous in-place coal resource assessments. It has revised its coal resource assessment methodology to determine the subset of in-place resources that is *technically and economically recoverable* on a basin-wide scale.

The USGS is now in the process of conducting a reserve estimate for the Gillette coalfield of the Powder River basin, the largest supplier of coal in the United States. The results of this effort are expected in winter of 2006, followed by the reserve estimates for the entire Powder River basin by the end of 2007.

Author's Note: In the "Recommendations" section of this report, a more dynamic approach to reserve estimation is suggested. It is believed that better coal reserve/resource information is needed to support long-term decision making than is available from the EIA or is being compiled by the USGS.

Limitations of DOE EIA Estimates

As previously discussed, the EIA's Estimates Recoverable Reserve of 270 billion tons is not believed to accurately reflect all the coal that will ultimately be recovered in the U.S. In a number of important cases too much coal in the Identified and DRB is eliminated or insufficient data exists to include it in the DRB from which the ERR is calculated. It is likely that the very large number of 270 billion tons has lessened the governments motivation to collect data that would move tons of recoverable resources from the Identified category to the DRB and then to the ERR. This is unfortunate, as many policymakers rely on the ERR for intermediate and long-range planning. With the role of coal expected to expand materially through the rapid emergence of coal-to-liquids and coal-to-gas production in the U.S., and future electric generating needs

anticipated to be substantially coal fired, the author believes a more accurate and dynamic approach to coal reserve estimation is urgently needed. To this end, recommendations have been made at the end of this chapter, which may prove useful as a guide for future resource and reserve methodologies. to the EIA, the USGS, and the states.

The EIA clearly recognizes some of these deficiencies, as the following paragraphs indicates¹²

By definition, the DRB does not represent all the coal in the ground. It represents coal that has been mapped, that meets DRB reliability and mineability criteria, and for which the data are publicly available. In some areas, the available source data for the DRB are old, and there may be evidence that some coal being mined is not covered in the DRB. In such cases, the DRB is presently out of date. As new data become available, those coal resources are revised via the CRDB program as new data become available. It is considered evidence that resource data and the DRB are out of date if reserves being mined supersede in quantity, location, or physical parameters the resources that have been demonstrated using available data. In isolated cases of this kind, EIA has selectively included inferred coal resources, not in the DRB, but in the data base used to develop certain coal supply forecasts.

Inferred coal resources are not listed in this report because they are less reliable than the DRB and because the coverage of inferred data is not consistent from one State to another. Recent CRDB (coal resource database) studies include updated DRB and inferred resources and they extend allocations and analyses to the inferred if supported by the geologic evidence. Even though inferred data are not published by EIA, they are retained on file to supply information about mining potential in important areas.

A more extensive analysis of reserve measurement limitations are outlined below, with a short discussion of each following.

- Estimates Out of Date
- Limited Public Data Available
- Inferred and Undiscovered Resources Neglected
- Mining Limits Out of Date
- Recovery Assumptions Questionable
- Mining Restrictions Assumed Permanent
- Technological Advancements Not Considered
- Only Surface Mining Reserves Assumed for Lignite
- Static and Not Dynamic Approach

Estimates Out of Date

One of the objectives of this report is to gain a better perspective on the currentness of existing state and federal U.S. coal estimates, and the capacity to update them. To do this, the

coal states were surveyed (see “State-by-State Coal Resource Survey Results” section below) and USGS and EIA coal staff were interviewed. This work indicates that a number of state coal estimates are based on data that was collected more than 50 years ago, and some of the assessments using these data date back to the 1960’s or 1970’s. Many states indicated that recent work had been conducted or was in progress that was not reflected in the DRB. But few of these recent state studies are comprehensive in scope.

The DOE EIA compiles its DRB and ERR estimates and the USGS compiles Identified Resources and Total Resources reported by the EIA. (see Figure 4 above). Identified Resources and Total Resources being published today by the DOE EIA are estimates from January 1, 1974, compiled and published by the U.S. Geological Survey in Coal Resources of the United States, January 1, 1974. These projections should be updated.

Our state coal survey indicates that the vast majority of the responding states (16 of 19 States) believe the EIA reserve estimates understate their Demonstrated Reserve Base. Nine of these states provided DRB estimates exceeding the current 500 billion ton EIA estimate by a total of approximately 275 billion tons (55% more than the current DRB estimate). One state, Virginia, noted that the DRB was representative. Only two states responded that the EIA DRB overestimated the DRB position of the state: Illinois provided a revised DRB estimated that was only 8.5 billion tons lower than the EIA DRB, and Pennsylvania generally indicated that the EIA estimate was too large. The overall consensus of the states was that the DRB is underestimated by EIA, with evidence that the magnitude of the shortfall is quite large. See “State-by-State Coal Resource Survey Results” for more details.

Most coal states have limited money to assess and evaluate their coal resources. Most state coal resource studies have historically been cooperative programs with the federal government. For this reason, they typically only evaluate the in-place tonnage, and do not make estimates of recoverability. This has been largely left up to the USGS and the EIA. There are issues with regard to estimates of recoverability, which are discussed in other sections of this chapter.

Interviews with the EIA have determined that the database of coal reserve/resource data that supports their estimates is not only substantially out of date in many states and regions, but is also in disarray, with some important data possibly missing or inaccessible.

The National Coal Council’s May 2006 coal study, Coal: America’s Energy Future, weighed in on the subject.¹³

The U.S. reserve base requires additional study. The foundation of the current DRB estimate is a one-time-only national assessment at the county/coalbed level reported in 1974 (BOM 1974) for reserves as of 1971 that was based upon then-current geologic knowledge and mining technology. The DRB has been updated numerous times (1989, 1993, 1996, and the previously referenced EIA reports), each time incorporating recent depletion and certain updated reserve data. However, the foundation of the current DRB remains the original 1974 study.

As previously discussed, the USGS has begun a program to take a fresh look at U.S. coal resources and reserves. Although revised estimates and a new approach are needed, there is concern that the approach being taken will not yield very useful results for intermediate and long-term decision making. The current USGS thrust is to evaluate U.S. coal basins to determine

“economically recoverable” reserves. This will result in estimates of profitably mineable coal at a fixed point in time, considering only current mining practices and costs, and current market prices, all within the current Demonstrated Reserve Base. This approach is expected to understate true potential over a reserve life. The USGS and others should be encouraged to broaden their reserve/resource estimation approach to include dynamic variables such as reserve growth and technological advancement in mining and utilization. Also more effort should be made at better delineating hypothetical and speculative resources. These and other observations and recommendations are enumerated below.

Limited Public Data Available

The EIA, USGS, and states typically do not have access to private industry exploration and development data, including extensive drilling and active mining information. They are limited to publicly available information on coal beds such as outcrop information, roadcuts, oil and gas wells, water wells, drill hole logs, and abandoned mine maps. With limited budgets, most states have not been able to document and explore sizable portions of their coal resources thus too much of the resource is in the identified category when it could be in the DRB and ERR. Thus, vast areas of the nation’s resources are not included in estimates meaningful for policy makers.

Illinois has address this problem by requiring that coal companies share their drilling information with the Illinois Geological Survey as condition of their receiving an exploration permit required to drill. The information is kept confidential by the state for ten years, but is available for use internally by Illinois to do resource work.

Limited public data results in high portions of a coal field or basin being classified in the Inferred or Undiscovered category, even when private company information may be available to designate portions of the area as Measure or Indicated. Inferred and Undiscovered resources are not included in the Demonstrated and Recoverable Reserve under current practices.

Inferred and Undiscovered Resources Ignored

While USGS Circular 891 permits practitioners to specify customized dimensions for reliability circles to reflect the variability of the deposits, most states use the recommended ¼-, ¾-, and 3-mile data spacing (Measured, Indicated and Inferred, respectively) to facilitate comparisons with other estimates. (see “Definition of Terms” and Figure 5 above). This means that reserves falling from ¾ of a mile to 3 miles from a coal measurement (drill hole, outcrop, etc.) are classified as Inferred, and anything outside of a 3 mile radius falls into the Undiscovered category. Therefore a large amount of coal in the Inferred category is not in the DRB and does not figure into the calculation of ERR. Knowledgeable experts in the field think the DRB excludes coal that is known to exist but for which data are sparse for a variety of reasons.

In Figure 4 (above) it is evident that the vast majority (about 2.5 trillion tons) of EIA’s total estimated U.S. coal resources are not included in the Demonstrated Reserve Base (DRB). The principal reason: they fall into the Identified and Undiscovered reserve classifications. It is believed highly likely that a sizable portion of these non-DRB coal measures will ultimately be recoverable both with current technology and through the advancement of coal recovery and utilization technologies.

Alaska provides a dramatic example of coal potential unrecognized by the EIA. Total hypothetical coal resources in Alaska exceed 5.5 trillion short tons, according to the most recent comprehensive state coal resource assessment.¹⁴ By comparison, the EIA/USGS estimate of total U.S. resources, including hypothetical measures, is 3.9 trillion tons. Alaska accounts for a meager 6.1 billion tons in the 2004 DRB estimate, even though state experts state that coal reserves in Alaska very likely surpass all coal resources in the lower 48 states.

This report asserts that the EIA's 500 billion ton DRB estimate reasonably reflects the ultimately recoverable U.S. coal reserves. To put this in perspective, it is believed possible that 500 billion tons of coal may ultimately be recoverable from Alaska alone.

Mining Limits Out of Date

As previously noted, USGS Circular 891 sets guidelines for DRB-qualifying seam thicknesses and mining depths, which are generally adhered to by the states. These guidelines suggest that only Measured and Indicated reserves meeting the following conditions are included in the DRB (1) beds of bituminous coal and anthracite 28 inches or more thick at depths to 1,000 feet, (2) beds of subbituminous coal 60 inches or more thick that occur at depths to 1,000 feet, and (3) and, beds of lignite 60 inches or more thick that can be surface mined.

Thinner and/or deeper beds are presently being mined than qualify to be in the DRB under Circular 891, and there is evidence that that additional resources outside these limits can be mined commercially today. Underground mining of up to about 2,500 foot depths is not unusual, and surface mining (and some underground mining) of coal less than 28" thick is common in the East. Technology will certainly allow even deeper and thinner seams to be mined, as has been the historic trend. Including only surface mineable lignite coal excludes billions of tons of potential in North Dakota, Texas, and other lignite bearing states.

Improvements in underground mining techniques, such as longwall mining, and the advent of robotic methods, and in-situ recovery techniques, are sure to allow deeper and thinner coal seams to be recovered over the next several centuries.

Consideration should certainly be given to technological advancements in estimating U.S. coal reserves available for mining over the intermediate and long-term. By not giving technology adequate weight, current methods are believed to materially understate U.S. coal reserves and potential.

Recovery Assumptions Questionable

Coal reserve recoverability is a function of coal that is determined to be accessible to mining, and the actual percentage of coal forecast to be recovered (by mining method) from each accessible coal boundary. Accessibility is addressed in the next section of this report.

The National Coal Council's May 2006 report, "Coal: America's Future," makes the following observations on coal recovery as it pertains to EIA reserve estimation.¹⁵

Also requiring additional study is the estimate of the recoverable portion of the DRB, which is estimated by EIA to be 54%. The U.S. Geological Survey

(USGS) has found, based on in-depth evaluations of selected coalbeds, that in the Appalachian Basin, an average of only 53% of the resource is available for mining (i.e., accessible within regulatory, land-use and technological constraints). There is an average of only 32% of the original resource recoverable after mining and washing losses. USGS also found similar percentages of availability and recoverability for coals in the Illinois Basin. USGS also reports that only 54% of the original coal in the Powder River Basin is available for development; recoverabilities must be even less. The National Coal Council (NCC 1987) speculated that the recoverability of the DRB could be as low as 35%, rather than EIA's 54%, on the basis of recoverability rates reported by some analyses (Schmidt 1979). The recoverability values reported by Schmidt and for selected Appalachian and Interior coalbeds by the USGS are both approximately 35%.

It is appropriate for the U.S. Department of Energy to perform or commission a new estimate of the DRB, and its recoverable fraction. The USGS has historically conducted coal assessments of in-place resources, with nominal restrictions on what is considered in the assessment process. They take into consideration depth, thickness and quality (ash yield and sulfur content). While in-place resources are important to understand and form a basis for further studies, policy decisions and land and resource management activities, it is also important to understand what portion of those resources are technically and economically recoverable.

It is agreed that coal recovery assumptions and estimates need to be reevaluated by the USGS and reflected in EIA resource projections. However, as discussed in “Recommendations” below, the track the USGS appears to be taking, attempting to estimate “economically recoverable reserves,” will not help to reveal the true potential of U.S. coal resources. Taking a snapshot of an economically mineable reserve basin or large area at a point in time will likely provide a poor gauge of recoverable reserves over the life of that resource. The dynamics of technological and productivity advancements, unpredictable market conditions and mining cost structures, improvements in transportation and infrastructure availability, and ever-changing political environments, suggest that a more flexible and dynamic approach be taken to reserve estimation.

Mining Restrictions Assumed Permanent

A key component in EIA Estimated Recoverable Reserve (ERR) calculations is coal believed to be restricted from mining. Technical restrictions such as seam height and depth restrictions have already been discussed. These will clearly change as technologies evolve. Land use and environmental restriction are also not necessarily permanent. Such constraints upon mining are established by societal policies to protect surface and ecological features (legal and environmental limits) that some consider could be negatively affected by mining. It is not uncommon that local land use and/or environmental restrictions to mining, especially land-use

restrictions, are mitigated. Laws and regulations can be and are frequently modified, waived, excepted, or repealed.

An example of a recent major land-use restriction is the Grand Staircase-Escalante National Monument, in Utah. In September of 1996 President Bill Clinton designated this enormous boundary of coal-bearing land as a National Monument, completely restricting mining. Escalante National Monument extends across 1.7 million acres in Utah's Kane and Garfield Counties, and includes some of the most energy-rich lands in the lower 48 states.

In January of 1997 M. Lee Allison, the then State Geologist for the Utah Geological Survey, published a report that included the following findings.¹⁶

The main mineral-resource issue is the enclosing of the Kaiparowits Plateau coal field within the monument boundary. The coal field is the largest in Utah, containing over 62 billion tons of coal in place (Hettinger and others, 1996). Using a resource assessment recently completed by the U.S. Geological Survey (USGS) and excluding resources considered unminable, the Utah Geological Survey (UGS) estimates that at a minimum, 11.36 billion tons of the coal resource are technologically recoverable from the entire field.

Note that 11.36 billion tons represent about 4% of the EIA estimated recoverable reserves in the U.S. This very low sulfur, high quality coal field is one of the premier coal fields in the American, and perhaps the world. It is not beyond the imagination that low impact mining may be authorized in this restricted area, and others, in the future.

The dynamics of change should be considered in U.S. coal reserve estimation. Technology will likely eliminate some and perhaps many environmental and land-use restrictions over time. The anticipated development of a strong National will for energy security and independence in the early 21st Century could also cause federal, state and local policy shifts that reduce coal mining restrictions. A converse political shift is possible.

It is recommended that future coal estimates be compiled to show each primary category of mining restriction, and lost tonnage associated therewith, as a separate line item. This would be invaluable to decision makers in government and industry, and to the American people. Policy decisions can then be based on better information reflecting the cost and benefit of coal mining restrictions and the value of changing or altering them.

Technological Advancements Not Considered

Advanced mining technologies will continue to extend the economic mining limits to deeper and thinner coal seams. Technology is also anticipated to mitigate some (perhaps substantial) land-use and environmental mining restrictions in the decades ahead. Technological improvements should be incorporated into the resource assessment framework, as they will clearly continue to increase access to resources currently deemed inaccessible, adding to the reserve base. Dramatic changes have occurred in mining and coal utilization over the past 50

years, and the rate of change is accelerating. Methods need to be developed to project improvements in technology as they relate to the expanding coal reserve recoverability.

Only Surface Mining Reserves Assumed for Lignite

The EIA only includes surface mineable reserves for lignite coals. Excluding underground mineable lignite overlooks billions of tons of potential in North Dakota, Texas, Montana, Mississippi, and other lignite bearing states. Underground mining technology advancements, and market needs are expected to allow for the ultimate recovery of some of these vast coal measures currently not included in the DRB.

Static and Not Dynamic Approach

Reserve growth through exploration, discovery, and technological evolution are believed to be inevitable. These dynamic forces should be taken into consideration in order to provide meaningful estimates of ultimately recoverable coal over the intermediate and long-term. Material changes in land use restrictions (as a result of increased National will to become more energy secure and independent, for example) are also possible, and should be considered, as well.

State-by-State Coal Resource Survey Results

All thirty-three states reported by the EIA to have coal resources were surveyed as part of this study to determine, among other things, whether each believed the EIA Demonstrated Reserve Base (DRB) was representative for their state. This survey, and all responses, are presented in Appendix 1 to this report.

Attached to each state survey was a table containing (1) the EIA 2004 DRB estimate for each state and (2) Identified Resources (based on state data) contained in the 2002 Keystone Industry Coal Manual.¹⁷ One of the questions asked in the survey was whether the EIA DRB or the Keystone Identified Resource projection best reflected the state's current estimate of the actual DRB.

A narrative discussing select survey results follows, beginning with reserve highlights. The color coding in Table 4 corresponds with the right-hand column of Table 3.









[This Space Left Blank Intentionally]

State Reserve Estimate Highlights

Thirty-three states were surveyed and nineteen states responded. Of the responses:

**Color Code for
Table 3.**

Table 4. State Responses

| | |
|---|--|
|  and  | 9 states provided DRB estimates exceeding current EIA estimates by 275 billion tons. |
|  | 2 states, Alaska and Louisiana, indicated that “Identified Resources” as published in the Keystone Coal Industry Manual ¹⁸ , was a better indicator of the DRB. |
|  | 7 states noted that their estimate of the DRB exceeds the EIA estimate, but gave no number. |
|  and  | 16 states in total indicated that the DRB should be higher than the EIA estimate. |
|  | 1 state, Virginia, reported that the EIA DRB was representative. |
|  | 1 state, Illinois reported a slightly lower numeric estimate DRB estimate than the EIA. |
|  | 1 state, Pennsylvania, provided an indication that the EIA DRB for their State was overstated. |

Sixteen of the 19 responding states indicated that the EIA DRB was understated, representing 84% of the returned surveys. One state indicated that the EIA DRB was representative. And two states out of 19 indicated that the EIA estimate was too high.

The right hand column of Table 3 (below) contains the state responses to the questionnaire with respect to whether they felt the DRB or Identified Resources was the best estimate of the state’s coal resources. Most states responded that the DRB was the closest figure, but that it excluded some resources that would be mineable. The label “> DRB” implies that the state would use a number somewhat greater than the DRB, but significantly less than the Keystone value (author’s interpretation in some cases).

TABLE 3. STATE-BY-STATE COAL RESERVE ANALYSIS (in millions unless otherwise noted)

| State | 2004 EIA Production (000s) | 2004 EIA Estimated Recoverable Reserves (ERR) | 2004 EIA ERR/DRB % | 2004 EIA Demonstrated Reserve Base (DRB) | Current State-DRB Estimate | Difference Between EIA and Current State-DRB | DRB Adjustment Assuming EIA Recovery % | 2002 Identified Resources (Keystone ¹⁹) | State Response to 2004 EIA DRB or Keystone Identified Resource |
|-------------------|----------------------------|---|--------------------|--|----------------------------|--|--|---|--|
| Wyoming | 396,493 | 41,804 | 64.99% | 64,325 | | | | 1,431,430 | > 2004 EIA DRB |
| West Virginia | 147,993 | 18,104 | 54.50% | 33,220 | | | | 94,618 | > 2004 EIA DRB |
| Kentucky Total | 114,244 | see Kentucky, Eastern and Western | | | | | | | |
| Kentucky, Eastern | 90,871 | 5,960 | 55.85% | 10,671 | 18,900 | 8,229 | 4,596 | 53,400 | 18.9 BT * |
| Pennsylvania | 65,996 | 11,822 | 42.84% | 27,597 | | | | 78,000 | < DRB |
| Texas | 45,863 | 9,578 | 76.98% | 12,442 | | | | 56,384 | No response |
| Montana | 39,989 | 74,989 | 62.87% | 119,280 | | | | 291,600 | > 2004 EIA DRB |
| Colorado | 39,870 | 9,798 | 60.14% | 16,293 | 20,000 | 3,707 | 2,229 | 434,000 | > 20 BT |
| Indiana | 35,110 | 4,080 | 42.79% | 9,534 | 59,500 | 49,966 | 21,383 | 34,059 | 59.5 BT |
| Illinois | 31,853 | 38,019 | 36.37% | 104,529 | 96,000 | -8,529 | -3,102 | 199,151 | 96 BT (available) |
| Virginia | 31,420 | 1,022 | 58.74% | 1,740 | | | | NA | DRB |
| North Dakota | 29,943 | 6,935 | 76.29% | 9,090 | 25,000 | 15,910 | 12,138 | 350,911 | 25 BT |
| New Mexico | 27,250 | 6,934 | 56.97% | 12,172 | | | | 39,466 | > 2004 EIA DRB |
| Kentucky, Western | 23,373 | 9,044 | 46.25% | 19,554 | 34,300 | 14,746 | 6,820 | 36,022 | 34.3 BT * |
| Ohio | 23,222 | 11,507 | 49.30% | 23,342 | | | | 39,470 | No response |
| Alabama | 22,271 | 2,806 | 66.15% | 4,242 | | | | 23,461 | > 2004 EIA DRB |
| Utah | 21,746 | 2,750 | 50.51% | 5,445 | | | | 42,560 | > 2004 EIA DRB |
| Arizona | 12,731 | 5 | 71.43% | 7 | 21,250 | 21,243 | 15,174 | NA | 21.25 BT |
| Washington | 5,653 | 681 | 50.78% | 1,341 | | | | 6,861 | No response |
| Maryland | 5,225 | 366 | 56.13% | 652 | | | | 852 | No response |
| Louisiana | 3,805 | 316 | 74.00% | 427 | 1,700 | 1,273 | 942 | 1,700 | Identified |
| Mississippi | 3,586 | 0 | 50.00% est. | 0 | 5,000 | 5,000 | 2,500 | NA | 5 BT |
| Tennessee | 2,887 | 462 | 59.31% | 779 | | | 0 | NA | No response |
| Oklahoma | 1,792 | 801 | 51.45% | 1,557 | | | 0 | 8,068 | No response |
| Alaska | 1,512 | 3,291 | 53.84% | 6,112 | 169,824 | 163,712 | 88,151 | 169,824 | Identified |
| Missouri | 578 | 3,847 | 64.22% | 5,990 | 7,630 | 1,640 | 1,053 | NA | 4.9 BT recoverable |
| Kansas | 71 | 681 | 69.99% | 973 | | | | 53,000 | >DRB (no underground) |
| Arkansas | 7 | 228 | 54.68% | 417 | | | | | No response |
| Georgia | 0 | 2 | 50.00% | 4 | | | | | No response |
| Idaho | 0 | 2 | 50.00% | 4 | | | | | No response |
| Iowa | 0 | 1,127 | 51.48% | 2,189 | | | | | No response |
| Michigan | 0 | 59 | 46.09% | 128 | | | | | No response |
| North Carolina | 0 | 5 | 45.45% | 11 | | | | | No response |
| Oregon | 0 | 9 | 52.94% | 17 | | | | | No response |
| South Dakota | 0 | 277 | 75.68% | 366 | | | | | No response |
| TOTALS | | 267,311 | 54.06% | 494,450 | | 276,897 | 151,884 | | |

Notes to Table 3:

EIA Production by State: EIA “Coal Production and Number of Mines by State and Mine Type,” 2004

<http://www.eia.doe.gov/cneaf/coal/page/acr/table1.html>

EIA Estimated Recoverable Reserves (ERR) and Demonstrated Reserve Base (DRB):

<http://www.eia.doe.gov/cneaf/coal/page/acr/table15.xls>

Identified Resources: Reported by the states to the Keystone Coal Industry Manual, 2002⁽²⁾

* Kentucky Geological Survey estimate of ultimate DRB, or resources ultimately available to mine. Does not strictly conform to USGS Circular 891 DRB guidelines.

Table 5.

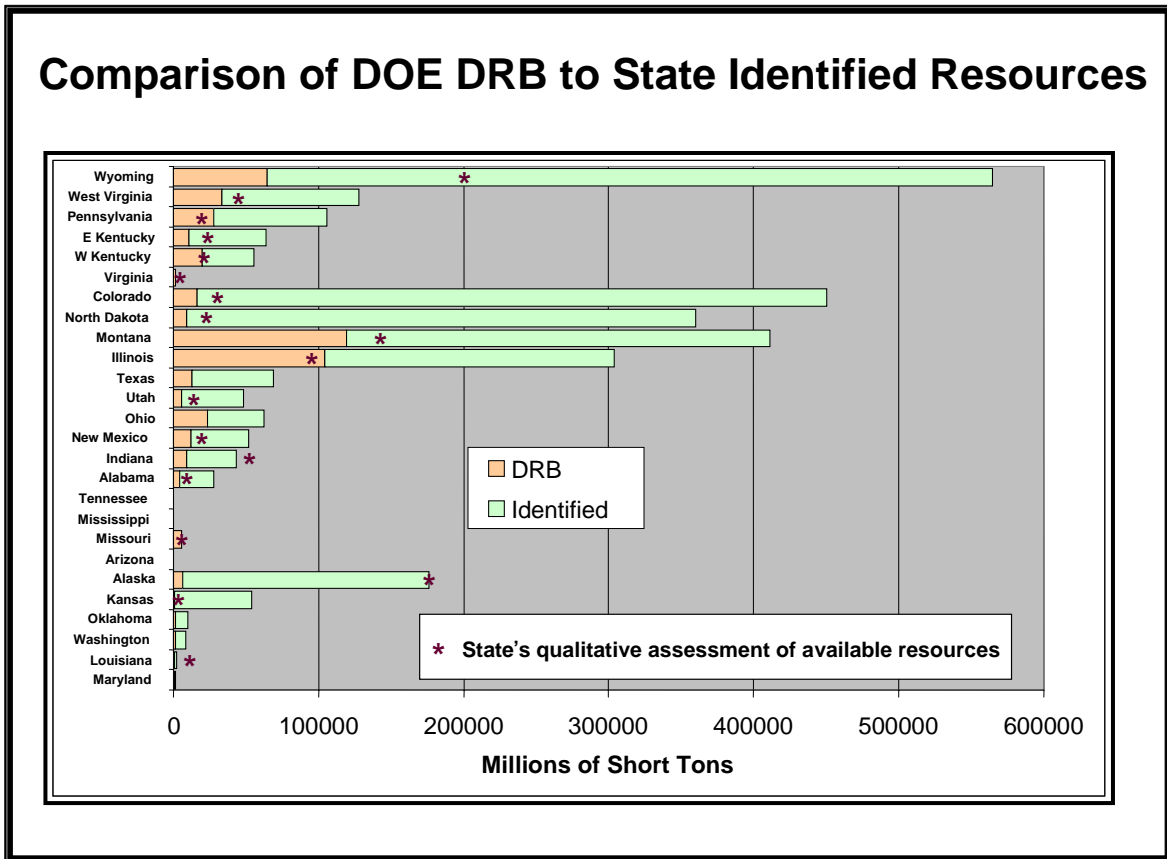

The following are selected highlight responses to the State Questionnaire, and comments and observations based on these responses.

Concerning the DRB and the ERR

In the case of the DRB, and consequently the ERR, it is clear that there is a substantial amount of coal in the U.S. that is not reported in these estimates because (1) the public agencies responsible for the work do not have access to all the information that is potentially available,

and (2) large areas with coal resources do not have coal data points with close enough spacing to be considered in the DRB. EIA periodically revises its estimates because coal is being mined in areas that are not included in the DRB. It is very conceivable that the DRB (and ERR) could double in magnitude if more coal exploration data were made available by the private sector, aggressive public coal resource programs were commissioned and funded, and if different criteria for reliability and depth were applied. At least in some regions where the continuity of coal beds is more uniform and current technology has demonstrated the ability to develop coal at greater depths than considered. A review of the assumptions used in deriving the DRB is called for. See “Recommendations.”

There is a reasonable consensus among the respondents that the DRB represents a minimum estimate of the Nation’s coal endowment. Many states are aware of coal that is currently being mined or could be mined in the future that is not reported in the DRB. In some cases, current mining practices suggest that the DRB criteria should be revised. For example, in the eastern U.S., coal is routinely mined at depths greater than 1000 ft, the maximum overburden allowed for the DRB.

The most problematic issue relates to the classification of resources by confidence of the estimate. While USGS Circular 891 permits practitioners to specify customized dimensions for reliability circles to reflect the variability of the deposits, most states use the recommended ¼-, ¾-, and 3-mile data spacing to facilitate comparisons with other estimates. Although standards are a worthy goal, the end result excludes resources from the demonstrated category where it would be reasonable to include them in the estimate. Many of the respondents noted this issue.

At the same time, most states recognize that Identified Resources contain much coal that is either too thin or deep to mine using current technology. This review suggests that the DRB is in the right order of magnitude, but that it needs to be adjusted to resolve the issues discussed above. The amount of this adjustment is uncertain, but conceivably could be on the order of several hundred billion tons.

States having the greatest remaining resources—Wyoming, Montana, Alaska, and Illinois—do not perceive the discrepancy between the DRB and Identified Resources to be a serious issue because either estimate is sufficient to support the objectives of increasing coal production. Yet, the potential for upgrading the DRB to a higher magnitude is greatest among these states.

Coal Quality Assessments

While the DRB is subdivided according to basic coal quality parameters (rank and sulfur content) the questionnaire indicates that few states assess their resources for quality because of inadequate data. Presumably the DRB estimates utilized an indirect method of assigning quality to the state’s resource allocations. Most respondents also indicated that basic coal quality parameters are no longer sufficient for characterizing the utilization and environmental parameters for coal and these additional analyses are even sparser. Coal quality data collected by the industry is often sensitive and companies are reluctant to release the records for public assessments.

Coal quality assessment is especially difficult in the eastern region where deposits are more variable and site specific data is critical for evaluation. Interior region states typically have

higher sulfur coal, however low sulfur coals do occur and their presence can, in some cases, be determined using proxy geologic criteria, such as the depositional character of the associated rock strata, resulting in reduced data requirements. States with lignite resources do not assess quality, and have little data to do so.

Respondents from western states differed with respect to the level of quality assessment that could be accomplished, but most indicated that the quality of their deposits was uniformly high, especially with respect to Clean Air Act parameters. Consequently, they did not consider that quality assessment was a pressing concern.

Increasing Coal Production

Evaluating the future potential for states to increase coal production for liquid fuel conversion is certainly influenced by current production levels by state. The following EIA data ranks coal production and the numbers of mines for the year 2004. States are grouped in three categories; major producer (greater than 50 million short tons), moderate producer (between 15 and 50 million short tons), and minor producer (less than 15 million short tons). Wyoming could be considered a super producer, because it is in a class of its own. An analysis of production trends over time for each state would be instructive, but is beyond the scope of this report.

Figure 6. 2004 coal production rankings for the US in thousands of short tons.

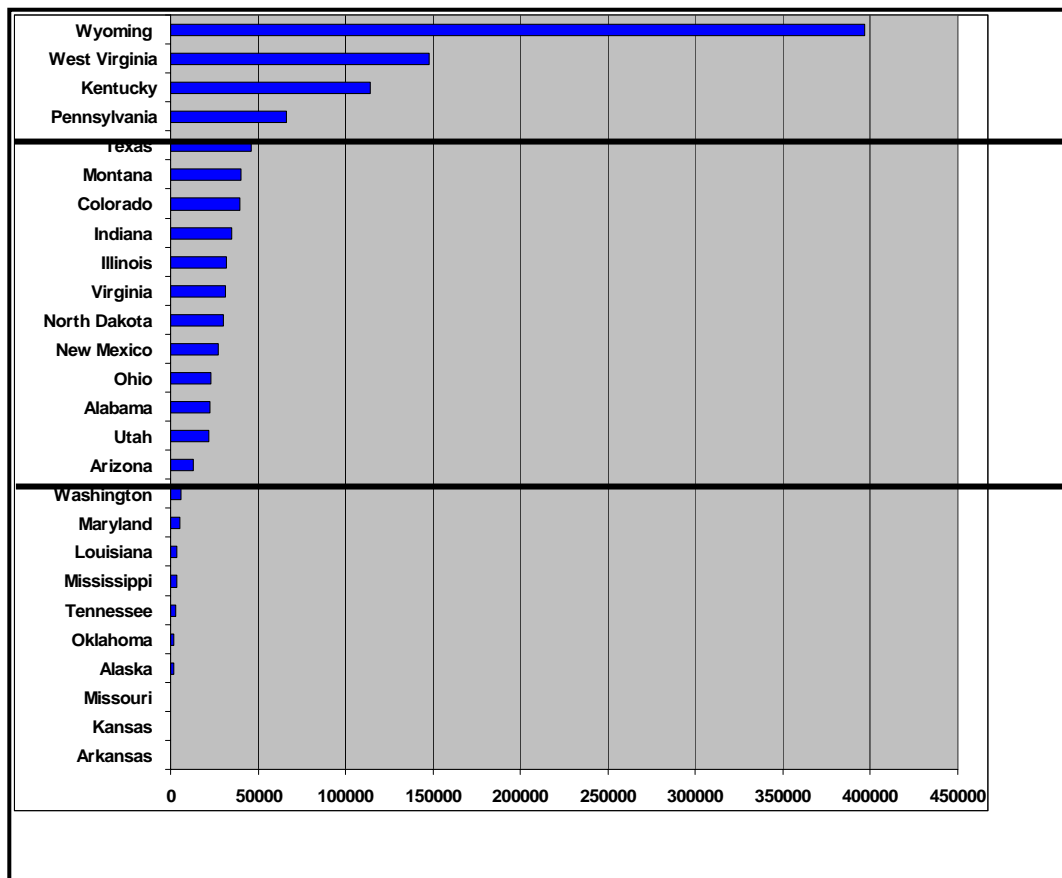

Source: <http://www.eia.doe.gov/cneaf/coal/page/acr/table1.html>

Western states, especially those including the Power River Basin and High Plains coal fields, express confidence that they can increase coal production to meet the nation's needs. These states are currently producing more than half the nation's coal from relatively few coal mines. Availability of resources will not be an issue for opening new mines to increase production.

Likewise, interior states of the Illinois Basin and Gulf Coast lignite belt believe that coal production could be significantly increased. These deposits do not have the same low sulfur quality characteristics that to Rock Mountain coals do. However, demand for higher sulfur products is increasing in the eastern United States due to the retrofitting of power plants with scrubber technology. Coal gasification and liquefaction are expected to increase the use of and demand for high sulfur production.

Eastern states in the Appalachian region were less optimistic that coal production in that region could be doubled for a significant period of time compared to western states. However, most respondents felt that production could increase from current levels. Among the major producing states of this region, West Virginia, Kentucky, and Pennsylvania, opportunities exist to increase coal production because of special coal quality considerations, proximity to markets, and a long history of coal development.

States with small coal production all felt that doubling coal production would not be problematic, but this would not significantly impact national production. The exception to this is Alaska, should infrastructural, transportation and environmental challenges in that state be overcome.

Challenges to Increasing Coal Production.

Given that much of the nation's future endowment will come from western states, there is consensus that increasing production in the region is dependent upon adding transportation infrastructure. Most respondents implied that their production had peaked at current levels because of limited rail capacity. Although liquid fuel production could be accomplished near the sites of mining, transporting the fuels would presumably face similar obstacles.

Alternatively, eastern and interior states cited workforce issues as major limiting factors to increasing production. Most of these states rely on underground mining for a large percent of their production, and this method requires a skilled and experienced workforce. The technical challenges of developing these resources are great, and there is also a shortage of engineers and geologists with expertise in coal mining.

Shortages of raw materials, especially steel, and equipment will also be a challenge to increasing production.

Coal Resource Research and Development.

One of the benefits of reviewing the questionnaires, as well as interviews with USGS and EIA coal staff, was gaining a perspective of the currentness of existing estimates and our capacity to update them. Many state estimates are based on data that was collected more than 50

years ago, and some of the assessments using these data date to the 1960's or 1970's. Many states indicated that recent work had been conducted or was in progress that was not reflected in the DRB, but few of these recent studies are comprehensive in scope.

Coal sections in many western states have been traditionally under staffed, but this is now beginning to change. Much of the public expertise in the west lies in the USGS and BLM. Even the eastern states that traditionally had strong coal research programs have lost experienced staff, or current staff have been reassigned to coal bed methane and carbon sequestration research projects. Consequently, there is an insufficient amount of resource assessment work being done in the nation, little funding to do it with, and a diminishing skilled workforce to meet the challenge. These trends must be changed for the future welfare of our nation.

Miscellaneous Questionnaire Results

Major Producers. Of the four major coal-producing states, Wyoming stands apart with respect to both production and resources. The responses suggest that the question of which estimate to use is irrelevant for Wyoming, because either is more than adequate to support significant increases in coal production for the long term. In this case, the DRB is a minimum estimate, and as new data are collected, the DRB is expected to increase because some Identified Resources in Inferred and Hypothetical categories will move to Measured and Indicated. Production could be increased by opening new mines, however transporting that coal to markets would require new infrastructure and permitting and environmental regulations require considerable time and expense.

The other three major coal-producing states are in the eastern region. Kentucky and West Virginia both consider the DRB to have excluded coal that is currently being mined, but the magnitude of the DRB is probably close to the amount of coal that will be available for mining. The DRB estimate for underground-mineable coal in eastern Kentucky is very low, and this is thought to be due to the lack of deep core data for the 1983 state estimate. Pennsylvania is more pessimistic about future production and considers the DRB to be a maximum number. Based on the responses for the three states, it seems unlikely that coal production could be sustained at levels twice current rates.

The answers to questionnaires suggested that serious impediments concerning permitting, availability of qualified labor, shortages of raw materials and equipment, and lack of infrastructure exist. From a resource standpoint, coal production in western Kentucky (Illinois Basin) could double. The eastern states also concur that the DRB and state estimates are based on old data (in some cases, very old) and that new assessment work is needed to produce more reliable estimates. West Virginia is currently engaged in such a program.

Moderate Producers. Moderate coal producers occur in all regions of the nation. Most of the western states in this group were not familiar with how the DRB was derived, and this is likely due to the fact that geological surveys in the west historically relied on the USGS for coal assessment work. Until recently, few of these geological surveys had geologists dedicated to coal research and assessment, and some still do not.

Like Wyoming, Montana indicates that either estimate is adequate to support significant increases in coal production, but that transportation, permitting, and environmental concerns may

be limiting factors. North Dakota suggests that it could easily increase production of its lignite resources. New Mexico, Colorado, and Utah all agree that the DRB understates their resources and each states that coal production could increase, but are less confident that production could be sustained without adding new transportation infrastructure. Among the western states, Utah is considered to have the most serious issues relating to land use.

The two eastern states in this production category, Alabama and Virginia, suggest that their DRB estimates are either accurate or slightly understated. Neither state feels that coal production could be doubled for a sustained period. Virginia cites workforce issues as a limiting factor, while Alabama cites coal quality and diminishing reserves that can be mined by longwall methods.

Illinois is one of the states in this group that could easily become a major coal producer. Their coal resources are well documented, abundant, and the beds are remarkably uniform. Indiana considers their coal resources are significantly higher than those reported in the DRB. Coal quality, permitting, and workforce issues are cited as limiting factors for increasing production in the Illinois Basin region.

Minor Producers. Alaska stands out among this group as having the greatest potential for dramatic increasing its coal production. Alaska probably has more coal than any other state in America, but its development has been hindered by its remote location, lack of transportation infrastructure, and environmental concerns. The DRB for Alaska is severely understated; in fact, the identified resource estimate may also be understated. Much of these resources lie north of the Brooks Range on the north slope, a remote and environmentally sensitive region.

Louisiana and Mississippi are lignite producing states in the interior region. Both consider that there are sufficient resources to double production, and that the DRB needs to be updated to reflect more recent studies. Similarly, the DRB reported for Arizona is clearly too low, because it is less than the annual production for that state. The state responded that it could double coal production, but that environmental concerns and water supply could be limiting factors.

The remaining states in this group have low annual production, and lack significant resources to impact the national energy outlook in a meaningful way. Most of these minor producers indicated that their state could double coal production, as long as a number of limiting factors could be mitigated.

Recommendations

National Reassessment.

Section 604 of the Energy Policy and Conservation Act Amendments of 2000 required an inventory that identified United States Geological Survey reserve estimates of the oil and gas resources. It is believed that a similar, comprehensive coal inventory is called for today, given the strategic significance of coal, and its projected rapid increase in use to make clean electricity, provide the energy for ethanol plants, and for use as a feedstock in the production of diesel and jet fuel, fertilizers, natural gas substitutes, hydrogen, and many other products.

In recent testimony before the Energy and Mineral Resources Subcommittee of the House Resources Committee, a staff member of the USGS commented about a coal re-assessment that is underway.²⁰

[The] USGS has embarked on a systematic inventory of the U.S. coal reserve base, representing a marked departure from previous in-place coal resource assessments. We have spent the last year revising our coal resource assessment methodology to determine the subset of in-place resources that is technically and economically recoverable on a basin-wide scale. In other words, USGS will start assessing the reserve base of the United States.

The USGS will focus on research efforts, working with agencies that have land and resource management responsibilities, such as Bureau of Land Management and Office of Surface Mining, and those agencies that use USGS resource projections for their mission work, such as the Energy Information Administration, so as to incorporate the needs of these customers into our products.

The USGS is now in the process of conducting a reserve estimate for the Gillette coalfield of the Powder River basin -- the largest supplier of coal in the United States. The results of this effort are expected in winter of 2006, followed by the reserve estimates for the entire Powder River basin by the end of 2007.

Subsequent coal reserve-based studies will be valuable in understanding how much of the domestic coal endowment is technologically available and currently economic to produce.

Studies of coal quality parameters are a core component of the USGS energy resources program research portfolio. The USGS has recently focused its efforts on studies that examine the feed coals and coal combustion products from individual coal-fired power plants. Coal quality parameters that will be examined include elements in coal that can potentially have adverse effects on environmental quality and/or may be slated for regulation.

Given the increasing attention on the impacts of coal utilization, coal quality research much address a more comprehensive suite of coal quality-related issues beyond the fundamental coal quality parameters, such as ash yield, sulfur content and heating value. This more comprehensive approach is vital to future coal assessments and future use of coal in this country.

The fact that the USGS is working on an updated coal reserve assessment is good and necessary. However, by only focusing on economically recoverable reserves, the USGS will not collect data or do assessments in the Undiscovered category (Hypothetical and Speculative categories) that stand the best chance of increasing the total coal endowment. Also the reserve estimates by the USGS using current economic and engineering scenarios will be out-of-date within a few years of completion.

Taking a snapshot of economically mineable reserves at a point in time will provide a poor gauge of recoverable reserves over the life of the resource. The failure to consider Inferred and Undiscovered Resources in the equation amplifies the shortfall. The dynamics of technological and productivity advancements, unpredictable market conditions and mining cost structures, transportation and infrastructure availability, and ever-changing political environments, suggest that a more flexible and dynamic approach be taken to reserve estimation.

It is believed that such a manpower intensive endeavor should be refocused to provide not only short-term but also intermediate and long-term estimates of recoverable U.S. coal. The following recommendations support this objective.

New Approach to Resource Estimation Indicated

There are virtually trillions of tons of coal resources in the U.S. that are not counted in our Nation's most cited estimates of the coal endowment. Inferred and Undiscovered categories are not included in the DRB. Coal located at depths of greater than 1,000 feet is generally excluded, although coal is now being mined in some U.S. regions at substantially greater depths. Land-use, technological, and environmental restrictions eliminate billions of additional tons from our resource base, although some of this coal will definitely become accessible in the future through technological advancements and policy and regulatory changes.

Clearly, major percentages of coal resources not currently included in the estimated recoverable base will ultimately prove to be recoverable. Conversely, portions of the tonnage reported in the reserve base will not ultimately be mined. In the net analysis, however, the current methodology is believed to substantially understate the potential of the U.S. coal endowment.

In order to give decision makers a more accurate picture, the system should be improved. One possibility is an evaluation and reporting approach that offers multiple levels of Estimated Recoverable Reserves (ERR). Below are three categories for consideration.

- Base Case (shorter-term focus, incorporating some reserve growth)
- ERR Intermediate-term Case (incorporating more reserve growth)
- ERR Long-Term Case (ultimately recoverable reserves, life of resource focus).

The USGS describes quantities of oil resources in terms of probabilities. Figure 7, below, shows estimated quantities of oil that might be economically recoverable in terms of the 95th percentile (19 in 20), expected mean value, and 5th percentile (one in 20) probabilities of exceeding a stated quantity.

Three measures of reserves are shown: (1) oil in-place--the amount of resource in the ground without regard to whether the oil can be technically recovered; (2) technically recoverable oil--representing the quantity of oil in place that is recoverable using current technology without regard to costs or profits; and (3) economically recoverable oil--the quantity of technically recoverable oil that can be recovered based on exploration, production and transportation costs, plus a 12 percent profit margin. In this example, there is a 95% chance of at least volume V_1 of economically recoverable oil, a 50% chance of at least volume V_3 , and a 5% chance of at least V_2 of economically recoverable oil.

We believe a similar approach would be valuable for coal reserve estimation. Reserve probability curves could be developed for each of the three cases listed above (Base,

Intermediate, and Long-term), to provide a dynamic framework for planning and decision making.

Figure 7. Probabilistic Oil Reserve Estimation Methodology ²¹

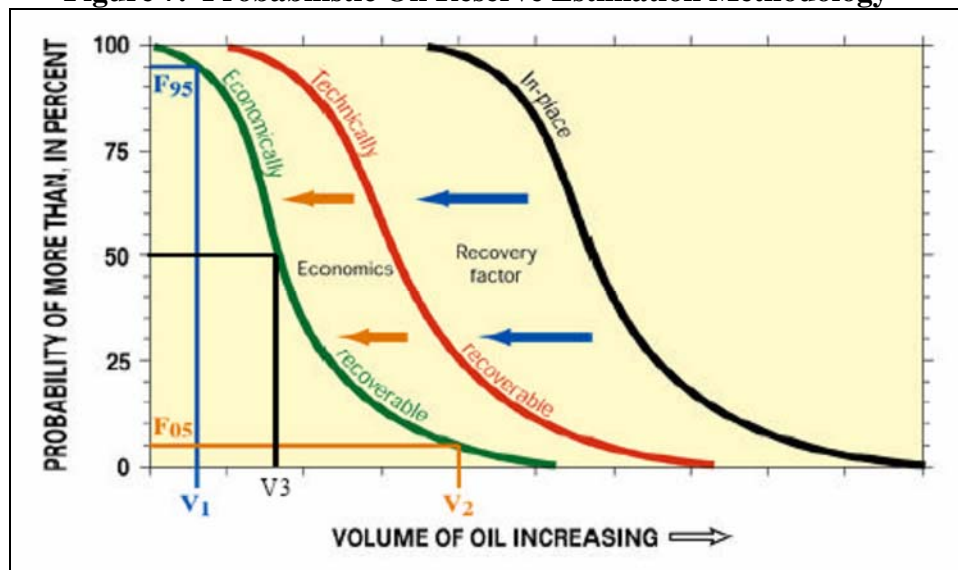

Exploration Programs and Methods. Federal and state funding should be authorized and appropriated to provide for more exploration of Inferred and Undiscovered Resource areas. In addition, scientific methods should be developed to make scientific predictions of recoverable reserves in Inferred and Undiscovered areas.

Restricted Reserves Highlighted by Restriction Category. From a policy perspective, it would be very valuable to understand how much coal is restricted from mining, and why. Future coal estimates should be compiled to show each primary category of mining restriction, and lost tonnage associated therewith, on at least a state-by-state basis.

Technology. Technological improvements should be incorporated into the resource assessment framework. Technology will continue to increase access to resources categorized as inaccessible. History has shown that advances in oil and gas drilling technology, for example, such as remote sensing methods, have dramatically increased industry's ability to access resources in an environmentally friendly manner. The continuing development of coal recovery technologies will certainly expand access, perhaps dramatically.

Research. Improved coal production, beneficiation, reclamation, transportation and utilization methods can and will increase recoverable coal reserves. Improved methods to recover greater percentages of in-place coal, mine at greater depths, extract from thinner seams, and have create less environmental impact, are just some examples of how technology will drive reserve growth.

It is recommended that Federal, state and local programs, and programs sponsored by private businesses, be encouraged to improved coal mining related technologies.

Education. With few exceptions, American's are poorly informed about the coal industry. This goes for the general public as well as for our political and business leaders. Coal is a much "cleaner" and safer, business than most believe. It's tremendous contributions to the U.S. energy mix not well understood.

Coal's strategic role in reducing dependence on imported oil and revitalizing American's energy and industrial base offers tremendous promise. The better our citizens and leaders understand this industry, the more accepting they will likely be of mining and utilization activities. Through education that encourages cooperation, it is possible that some mining restrictions may be relaxed without harmful environmental or social effect. This offers the potential to expanding the mineable reserve base.

It is recommended that Federal, state and local programs, and programs sponsored by private businesses, be encouraged to broaden American understanding of this vital industry.

Incentives for Upgrading Transportation Systems and Infrastructure.²² Federal and state tax incentives should be put in place to support taxpayers who invest in railroad and road infrastructure capacity. Congress should appropriate additional funds for the upgrade of the inland waterway system, including barge access.

Ensure that Existing, Identified and Undiscovered Coal Reserves Remain Part of the Resource Base.²³

- Seek balance between precautionary protectionist policies and energy security
- Support active enforcement of existing laws, including The Clean Water Act, the Endangered Species Act, the Surface Mining Control and Reclamation Act, and the Wilderness Act
- Actively involve the DOE in addressing energy security in any policymaking that would "sterilize" significant coal reserves
- Oppose overlapping and additional regulation that needlessly reduces access to the United States' most abundant energy resource—coal. Recent examples would be the last-minute inclusion of the Kaiparowits Plateau in the Grand Staircase-Escalante National Monument designation and the Forest Service's recently extended Roadless Forest Protection to July 16, 2007.
- Develop a plan to eliminate coal reserve restrictions such as the Grand Staircase-Escalante National Monument where benefit outweigh costs.

Continuing to support the provisions of the Mine Safety and Health Act by:²⁴

- Ensuring a progressive approach to the important issue of enhancing mine safety and working to provide enhanced funding for mine safety research by the National Institute for Occupational Safety and Health (NIOSH)

References

- ¹ Dept. of Hi-Tech Development and Industrialization, Ministry of Science and Technology of China, “Development Strategies of China’s Energy Technologies,” PowerPoint, February 14, 2006, Beijing
- ² DOE EIA, “Recoverable Coal Reserves at Producing Mines, Estimated Recoverable Reserves, and Demonstrated Reserve Base by Mining Method”, [<http://www.eia.doe.gov/cneaf/coal/page/acr/table15.html>], 2004, Table 15
- ³ *ibid.*
- ⁴ DOE EIA, “EIA Coal Reserves Data,” [<http://www.eia.doe.gov/cneaf/coal/reserves/chapter1.html#fig2>], 1997. Estimates actually compiled by the USGS.
- ⁵ *ibid.*
- ⁶ DOE EIA, “Recoverable Coal Reserves at Producing Mines, Estimated Recoverable Reserves, and Demonstrated Reserve Base by Mining Method”, [<http://www.eia.doe.gov/cneaf/coal/page/acr/table15.html>], 2004, Table 15
- ⁷ “BP Statistical Review of World Energy 2005,” [<http://www.bp.com/genericsection.do?categoryId=92&contentId=7005893>], June 14, 2005
- ⁸ Wood, G.H., Jr., Kehn, T.M., Carter, M.D., and Culbertson, W.C., 1983, Coal resource classification system of the U.S. Geological Survey: USGS Circular 891, 65 p.
- ⁹ DOE EIA, “EIA Coal Reserves Data,” [<http://www.eia.doe.gov/cneaf/coal/reserves/chapter1.html#fig2>], 1997
- ¹⁰ DOE EIA, “COAL GLOSSERY,” [<http://www.eia.doe.gov/cneaf/coal/page/gloss.html>], October 6, 2004
- ¹¹ Wood, G.H., Jr., Kehn, T.M., Carter, M.D., and Culbertson, W.C., 1983, Coal resource classification system of the U.S. Geological Survey: USGS Circular 891.
- ¹² DOE EIA, EIA Coal Reserves Data, [<http://www.eia.doe.gov/cneaf/coal/reserves/chapter1.html>], 1997
- ¹³ The National Coal Council, “Coal: America’s Energy Future,” May 2006, Pg. 101
- ¹⁴ Alaska Department of Natural Resources in cooperation with the Alaska Coal Association, “Map of Alaska Coal Resources,” compiled by R.D. Merritt and C.C. Hawley, 1986.
- ¹⁵ The National Coal Council, “Coal: America’s Energy Future,” May 2006, Pg. 101
- ¹⁶ Allison, M. Lee, “A Preliminary Assessment of Energy and Mineral Resources within the Grand Staircase - Escalante National Monument,” [<http://geology.utah.gov/online/c/c-93/index.htm>], January 1997
- ¹⁷ Keystone Coal Industry Manual, 2002, Steve Fiscor, ed.: CoalAge, Primedia, Chicago, IL, 736 p.
- ¹⁸ *ibid.*
- ¹⁹ *ibid.*
- ²⁰ Brenda Peirce, U.S. Geological Survey, testimony before the Energy and Mineral Resources Subcommittee of the House Resources Committee, Longworth House Office Building, Washington, D.C. 10:00 a.m., May 4, 2006
- ²¹ Morton, Peter A., The Wilderness Society, Testimony Before The Subcommittee on Energy and Mineral Resources, Committee on Resources, U.S. House of Representatives, April 18, 2002
- ²² The National Coal Council, “Coal: America’s Energy Future,” May 2006, Pg. 13
- ²³ *ibid.*
- ²⁴ The National Coal Council, “Coal: America’s Energy Future,” May 2006, Pg. 14

APPENDIX C: COAL RESOURCE SURVEY

Questionnaire

Please answer these five questions for the survey

1. 1. The DRB eliminates certain categories of thickness, reliability, and depth from identified resources (See attached table for the difference between the DRB and your estimate resources). Do you feel that the particular assumptions about the availability of coal for your area are reasonable? Please be specific.
2. 2. Is coal currently being mined in your state from resource categories that are excluded from the DRB? Specify.
3. 3. Do you feel that Identified Resources, the DRB, or another methodology most closely represents the coal in your state that would be available for mining in the next two decades?
4. 4. If coal demand increased two-fold (presumably with an associated rise in prices) do you feel that your state could significantly increase production to meet that demand?
5. 5. What factors might impede increasing coal production?

Optionally, submit answers for the following questions for additional background

1. 6. What is the source (published or unpublished) of the most recent comprehensive coal resource estimate for your state?
2. 7. What is the source of data that the Energy Information Agency (EIA) used for the 1997 Demonstrated Reserve Base (DRB) estimate?
(<http://www.eia.doe.gov/cneaf/coal/reserves/database.html>)
3. 8. What is the approximate accuracy (in map scale) of geologic mapping that was used to prepare your state resource estimates?
4. 9. How are coal production statistics compiled for your state?
5. 10. What methods are used to adjust your in-place resource estimates for annual production (e.g., GIS, arithmetic subtraction from totals, etc.)?

6. 11. Do your estimates include categorization by depth?
7. 12. If so, what basic methods were used to estimate overburden (e.g., GIS, manual contouring or mapping)?
8. 13. Are your estimates categorized by basic coal quality parameters?
9. 14. If so, describe the methodology for applying quality to resources.
10. 15. Do you feel that you have sufficient data to evaluate your resources by pertinent quality parameters?

Appendix 2

Questionnaire Results

1. The DRB eliminates certain categories of thickness, reliability, and depth from identified resources (See attached table for the difference between the DRB and your estimate resources). Do you feel that the particular assumptions about the availability of coal for your area are reasonable?

Appalachian

Alabama

Most assumptions used to develop the DRB for Alabama are valid. However, the thickness limitation of 14 inches excludes many thin coal beds that are mined with the major resource beds at the surface. For this reason, Alabama's DRB for surface-minable coal is conservative.

Kentucky

The underground portion of eastern Kentucky's DRB is clearly too low. Its difficult to ascertain what categories were erroneously eliminated because the DRB is not reported by all resource categories. Its likely that a significant amount of coal in the "Inferred" resource category could account for the difference, and this coal is probably a viable resource.

Pennsylvania

The DRB (and Keystone) figures are ultimately based on the 1970 estimates of W. E. Edmunds, which were in turn based on estimates by Reese and Sisler (1928). Both of these studies made gross assumptions that were based on limited information that have subsequently proven to be over estimates.

Virginia

The assumptions used in calculation of the DRB are considered reasonable. There are no production figures reported for comparison by the Keystone Coal Industry manual (2002) for Virginia.

West Virginia

First, its important to understand that the DRB for West Virginia reported by the U.S. Department of Energy, Energy Information Agency was not entirely derived by comprehensive coal bed mapping and the use of the standardized definitions and guidelines set forth in USGS Circular 891, Coal Resources Classification System of the U.S. Geological Survey. The DRB for 11 counties in West Virginia is based on a combination of estimates of coking coal reserves conducted by the now defunct U.S. Bureau of Mines and extrapolation from reconnaissance estimates of original resources (all coal greater than 12 inches thick) made by the West Virginia Geological and Economic Survey between 1900 and 1940 for non-coking coal in the 11 counties. The DRB for the other 33 counties with coal resources was made entirely by extrapolation from reconnaissance estimates of original resources (all coal greater than 12 inches thick) made by the West Virginia Geological and Economic Survey between 1900 and 1940. (More information about the methodology used to derive the DRB in West Virginia is available upon request.) The tonnage estimate reported in the Keystone Manual is the reconnaissance estimate of original resources made by the West Virginia Geological and Economic Survey between 1900 and 1940 (all coal greater than 12 inches thick) debited by cumulative production and an estimate of lost-in-mining. These estimates are as reasonable as the data that went into them. Only comprehensive bed mapping and new resource and reserve calculations, following a well-defined procedure, will provide more sound and meaningful results.

1. The DRB eliminates certain categories of thickness, reliability, and depth from identified resources (See attached table for the difference between the DRB and your estimate resources). Do you feel that the particular assumptions about the availability of coal for your area are reasonable?

Interior

Illinois

The DRB for Illinois was completed by the ISGS in 1997 using the parameters established for the DRB at the time, such as depth, thickness and others. Subsequent new research studies, namely the ISGS Coal Availability studies (completed in 2003), have established a newer 'identified resources' number of 211 billion tons, 12 billion greater than that determined by the 1997 DRB studies. Of this amount we have determined that 96 billion tons are currently available. Our Coal Availability studies, completed in 2003, use a variety of geologic and technologic criteria, including many parameters established from interviews with active coal companies that, while similar to

the DRB assumptions, are different and better representative of coal most likely to be mined in Illinois.

Indiana

Resources for Indiana listed in the DRB are significantly lower than they should be. Recent evaluations give 59.5 billion short tons (Mastalerz et al, 2004, table 15). Previous estimates were less detailed (the current ones are GIS-based).

Kansas

The DRB is based on Brady, Adams, and Livingston (1976). See full reference in reply to Question #7. Based on this study the original DRB was 998 million tons and deduction of annual coal production subtracted over the years. This is only strippable coal. The large number as shown in Keystone includes coal deeper than 100 ft., and includes inferred category as well as measured and indicated thickness estimates based mainly on oil and gas geophysical logs.

Kentucky

The assumptions about the western Kentucky coal field are generally reasonable, except those related to reliability. Because of the high degree of lateral continuity of coals in this field, we are confident in the existence of coal, even when we may lack site-specific data in some areas. The DRB included coal between 28 and 42 inches in thickness, and little of this coal is likely to be mined due to the abundance of thicker coal, and to the higher costs of developing thin coal mines in the region.

Louisiana

No. Recent work done in cooperation with the USGS does not appear to be included.

Mississippi

Not applicable. There are no reserves given for Mississippi.

Missouri

There are currently no estimates listed for Missouri in the DRB or Keystone Manual. The last estimates produced by the state were published in 1981. These estimates were calculated from data collected from June 1975 through July 1976 and published in Missouri publication RI 66.

1. The DRB eliminates certain categories of thickness, reliability, and depth from identified resources (See attached table for the difference between the DRB and your estimate resources). Do you feel that the particular assumptions about the availability of coal for your area are reasonable?

Western

Alaska

The data presented in the DRB is not reasonable for the actual coal resources in Alaska that are available for mining. The DRB for Alaska is based largely on a 1967 publication by Barnes, Coal resources of Alaska: U.S. Geological Survey Bulletin 1242-B; 1971 U.S. Bureau of Mines Information Circular 8531, and 1975 U.S. Bureau of Mines Information

Circular 8693. This data is out of date and there have been over twenty newer publications or reports on Alaska's coal resources that include some demonstrated reserve data (see attached list of references). For example the Usibelli coal mine in the interior has been mining annually in areas that weren't assessed at that that time. Deadfall syncline in the Arctic northwest wasn't drilled until the 1980's. Other areas that have been more recently assessed include Beluga-Capps, NPRA, Colville Mining District, Chicago Creek, and Jarvis Creek.

Arizona

No. The DRB numbers are way, way off target. Arizona annual coal production is higher than the DRB figures for total resources. According to the DRB, Arizona coal resources amount to 7 million short tons. However, according to USGS Prof. Paper 1625-B, Chapter H, p8, coal production was 10-13 million tons per year (1975-1995). Production has likely been in the same range since then, until this year when a large coal-fired power plant shut down for environmental compliance reasons, eliminating the largest market for Arizona coal.

Colorado

No. Our studies show that approximately 60 percent of the state of Colorado's coal-bearing strata has been categorized. When comparing the DRB and the Keystone values for Colorado, there is a large discrepancy: the DRB is 16.293 billion short tons, and the Keystone data shows 434 billion short tons. The DRB only calculates coal in the 'measured' and 'indicated' resource categories around existing drill holes or measured sections down to 2,000 ft deep. The Keystone data counts all coal on an 'identified' and perhaps 'undiscovered' resource basis using the areal extent of the coal-bearing strata, assumes uniform coal thickness throughout, and calculates coal to 6,000 ft. Please refer to U.S. GEOLOGICAL SURVEY BULLETIN 1450-B for definitions. An important consideration about the DRB is that as an economic reserve study conducted in the 1970s, it calculated coal that might be mined in the near future. Such is the nature of a reserve study. The main reason that the DRB and Identified resources are different is due to the volume of "Inferred" coal not calculated in the DRB. The demonstrated category of coal may have been mined in the last 30 years since the DRB was last updated. Much of the coal mined today in Colorado may actually fall into the inferred category of resources, and not be in the DRB

The DRB is also time sensitive, in terms of reliability data and mining depletion. The DRB for the U.S. was last updated on Jan 1, 1997, or more than nine years ago. The CGS updated the Somerset and Yampa coal fields in 1999 and 2000 for the DOE/EIA, but they have not input the numbers in their calculation of 16 billion tons. We calculate that the DRB for Colorado should be over 20 billion tons now.

1. The DRB eliminates certain categories of thickness, reliability, and depth from identified resources (See attached table for the difference between the DRB and your estimate resources). Do you feel that the particular assumptions about the availability of coal for your area are reasonable?

Montana

We have only limited information on how the DRB restrictions were calculated and applied. My feeling is that the DRB reserves, which are much smaller than the Keystone

numbers, probably more accurately reflect mineable reserves in Montana, and certainly include enough reserves to support mining at current, or even considerably increased rates, for decades.

New Mexico

I do not have a problem with using measured and indicated categories only because New Mexico coals are lenticular. However, by eliminating the inferred category resources can be underestimated in those cases where the data indicates there is good potential, but the available data is sparse.

North Dakota

North Dakota used all of the existing coal (down to a thickness of one foot) in the Fort Union Group (a maximum depth of about 1,800 feet) to calculate the lignite resources of North Dakota. The database that was used to calculate North Dakota's lignite resources and reserves contained over 20,000 control points. Lignite deposits had to meet a series of economic criteria established by the coal companies currently mining in North Dakota before they were counted as reserves (minimum thickness of 10 feet of coal occurring in two or less beds, deeper than 25 feet but no deeper than 170 feet, no more than a 10:1 stripping ratio, minimum bed thickness of 2.5 feet.

Utah

The UGS understands the basic methodology used by EIA for calculating the DRB, but we lack specific information on how those thickness and depth assumptions have been applied to Utah resources to know if we agree or disagree with what resources are included or not included in the DRB. Further, we don't even know exactly what resources from the 22 coalfields in the state are included in the DRB.

Wyoming

Yes, Wyoming's DRB is reasonable, however is out of date. The DRB was published in 1978 and again reprinted in 1992, (Coal Fields and Coal Beds of Wyoming, Glass and Jones, WSGS reprint No. 47, 1992) The future DRB is expected to be higher than the previously determined DRB. As oil and gas and coalbed natural gas development has dramatically increased the number of geophysical well logs that are available for coal resource assessment (measured, indicated, and inferred). Additionally advances in mining technology and mine plan engineering will allow for additional tonnages of minable reserves to be incorporated into the DRB. Much of what is deemed to be classified as a demonstrated reserve base relies heavily on several factors: including the availability of data, mining method, current mining technology, land use restrictions, and ultimately what is deemed economically recoverable by today's coal mine operators.

2. Is coal currently being mined in your state from resource categories that are excluded from the DRB?

Appalachian

Alabama

Yes. Deep coal reserves that have been classified as inferred are being mined in Tuscaloosa County and constitute approximately half of Alabama's annual coal production.

Kentucky

Probably a significant amount from "Inferred" coal. At the time of making the original resource estimates, few core holes were available to KGS to assess deep coal. Its also common in eastern Kentucky to mine coal locally at depths up to 2500 feet or more. Because the original resource estimates were not classified according to depth, its unclear whether this coal was eliminated from the DRB.

Pennsylvania

Yes. The DRB excludes coals thinner than 28" and surface mining in Pennsylvania commonly targets thinner seams (and multiple thin seams). Also, many of the reserves on the Pittsburgh and Upper Freeport seams in Washington and Green Counties occur at depths greater than 1000 ft.

Virginia

Generally no. The DRB excludes mines that produce < 10,000 short tons.

West Virginia

Yes. Coal is routinely mined at depths exceeding 1000 feet of overburden. Generally speaking, coal is not mined less than 28 inches thick except in mountaintop mining operations where thinner beds are recovered but only because thicker beds are present within the working interval of the operation. Obviously, coal is being mined that would fall into the inferred category, but that is an artifact of not all of the data being available to the West Virginia Geological and Economic Survey.

Interior

Illinois

No, not that we are aware of. Some coals classified as underground minable according to DRB specifications may actually be surface mined. This is because there are instances of surface mining in coal deeper than 150', the cut-off depth for DRB surface minable coal. This does not affect, however, the total DRB values, nor the general classification of minable versus non-minable coal for the DRB regardless of mining method. In contrast, our Coal Availability studies use a favorable stripping ratio and a maximum depth of up to 200 feet to define surface minable coal. As far as we are aware, all the coal being mined in Illinois lies in areas classified as 'Available Coal' in our 1994 – 2003 Coal Availability studies.

Indiana

No response.

2. Is coal currently being mined in your state from resource categories that are excluded from the DRB?

Kansas

No

Kentucky

There is coal being mined from both the inferred resource category, as well as at depths greater than 1000 feet.

Louisiana

Not to my knowledge.

Mississippi

Lignite is currently being mined in Mississippi (3.5 million tons per year), but no reserves are given for Mississippi in either reserve estimate.

Missouri

The 2004 DRB has not been estimated for Missouri, however, there is coal currently being mined in the state.

Western

Alaska

Yes, coal currently being mined in Alaska from resource categories not included in the DRB. The Usibelli Coal Mine is mining from areas in the Healy, Alaska not included in any 1967 and subsequent 1971 and 1975 assessment.

Arizona

We believe so, but the DRB methodology is unknown to our staff, so we cannot evaluate this. We do not have coal expertise on staff.

Colorado

Yes. Since the DRB was calculated there has been a significant amount of coal drilling since that time. Over 5,000 coalbed methane (cbm) wells have been drilled in Colorado since 1996. Very little coal mining has occurred in those areas, but the potential for future mining can be derived from that cbm database. Colorado coal mines have produced 300 million tons of coal since 1996, or 25 percent of the cumulative historic coal mining since 1864. Much of this was within the DRB established by DOE/EIA, but remember that estimate is excluded only to drill hole locations. Many of the active coal mines are probably mining coal that was classified as 'inferred' resources in 1996.

Montana

No

New Mexico

Probably, many of our mines have been operating for 20+ years and are at a point where they could be surface mining coals at depths greater than 200 ft and thickness of 2.5-5 ft, which does not fit into the DRB category scheme.

2. Is coal currently being mined in your state from resource categories that are excluded from the DRB?

North Dakota

Not sure of the DRB categories. I went on the website but could not determine what had been excluded.

Utah

Probably not, but we don't know for sure.

Wyoming

Currently, all coal mining operations in Wyoming are operating within the 1978 DRB. Initially there were 10 coal mines in the Powder River Basin, which is host to the majority of Wyoming's coal resources. Today there are 14 active mines operating within the PRB all of which are within the DRB.

8. What is the approximate accuracy (in map scale) of geologic mapping that was used to prepare your state resource estimates?

Appalachian

Alabama

1:24,000

Kentucky

1:24,000

Pennsylvania

1: 62,500. Completed in 1928 (Reese and Sisler) U.S.G.S assessment used 1: 24,000 for the Pittsburgh and Upper Freeport seams.

Virginia

Resource estimates are currently being compiled based on geologic mapping at the 1:24,000 scale.

West Virginia

The reconnaissance estimate of original resources made by the West Virginia Geological and Economic Survey between 1900 and 1940 (all coal greater than 12 inches thick) was based on 1:62,500 scale mapping. Coking coal estimates made by the U.S. Bureau of

Mines were made from 1:14,400 (1 inch = 1,200 feet) coal base maps. The current mapping is being done on 1:24,000 scale topographic base maps.

Interior

Illinois

Original maps ranged from 1:24K to 1:125K, to outcrop studies of even greater detail.

Indiana

Varies depending on the source.

Kansas

Most of the 1976 strippable coal study was based on coal company drill records and plotted on 7.5' USGS topographic maps. Most of the 1990 study was based on 7.5' USGS topographic maps with well locations hand plotted and these location digitized for the USGS-NCRDS computer files.

Kentucky

1:24,000

Louisiana

Unknown, probably 1:62,500.

8. What is the approximate accuracy (in map scale) of geologic mapping that was used to prepare your state resource estimates?

Mississippi

Not applicable.

Missouri

Most maps are at a scale of 1:100,000 to 1:250,000.

Western

Alaska

There is a wide range of mapping scales from 1:63,260-to 1:250,000 scale. Most of the coal resources are not based on any geologic mapping, but are from points that have been provided in geologic reports, then co-located to topographic maps, and finally coal resources are then calculated.

Arizona

Unknown

Colorado

This varies from 1:24,000 scale to 1:250,000 scale mapping. Using GIS we start with the 1:250,000 scale maps and digitize detailed geology from 1:24,000 scale mapping in just those areas which have been mapped. This may be approximately 30 percent of the area at 1:24,000.

Montana

The largest deposits were extensively drilled in the 1970's and 1:24,000 maps were used in compilation of reserves. Only the earliest part of that data would have been incorporated into the Averitt publication. Reserves or resources for most other areas are based mostly on USGS work prior to 1950, and derive from smaller scale maps of unknown parentage.

New Mexico

1:100,000 map scale.

North Dakota

1:24,000.

Utah

Doelling's (1972) study was from 1:42,400 scale mapping; recent UGS coal availability studies were based on data from 1:24,000 scale mapping.

Wyoming

Previous map scales ranged from 7.5 minute or 1:24,000 up to 1:100,000. Current efforts are focusing in on much lower scale that is dependent upon the availability of bore-hole data, approximately 40 acres.

7. What is the source of data that the Energy Information Agency (EIA) used for the 1997 Demonstrated Reserve Base (DRB) estimate?

Appalachian

Alabama

Uncertain

Kentucky

The 1997 DRB cites an earlier coal resource study conducted in the 1950's (USGS Bulletin 1120), but it appears that more recent DRB estimates are based on the Brant studies of 1983.

Pennsylvania

Same as question 6 and assorted data in EIA's files and U.S.G.S. USCHEM files.

Virginia

Primarily MSHA form 7000-2 "Quarterly Mine Employment and Coal Production Report".

West Virginia

See #1 above.

Interior

Illinois

That data comes from a contract the ISGS had with the DOE. The data can be found in the final report (Coop agreement DE-FC01-94E124855, Open file series 1997- 4 from the ISGS).

Indiana

CE Wier, Coal Resources of Indiana, IGS Bulletin 42-I, 1973 2) Indiana Geological Survey, Preliminary Coal Maps, PCM 1 through PCM 15 3) F.D. Spencer, USGS Circular 266, 1953.

Kansas

Brady, L.L., Adams, D.B., and Livingston, N.D., 1976, An evaluation of the strippable coal reserves in Kansas: Kansas Geological Survey Mineral Resources Series 5, 40 p.

Note: This is actually resources rather than reserves as indicated in the title, and based on the USGS-USBM standards for measured, indicated, and inferred. A minimum cutoff of 12" was used for coal thickness because that thickness was mined in the state at that time.

Kentucky

Smith, G. E., and Brant, R. A., 1980, Western Kentucky Coal Resources. University of Kentucky Institute for Mining and Minerals Research, Energy Resources Series, 148p.

Louisiana

The Louisiana Office of Conservation.

Mississippi

Not applicable; Mississippi has no reserves in this database.

7. What is the source of data that the Energy Information Agency (EIA) used for the 1997 Demonstrated Reserve Base (DRB) estimate?

Missouri

It is not clear, however, based on the estimates, we have to assume they used the before mentioned Missouri publication.

Western

Alaska

Barnes, F.F., 1967, Coal resources of Alaska: U.S. Geological Survey Bulletin 1242-B, p. B1B36, 1 sheet, scale 1:2,500,000.

.U.S. Bureau of Mines, 1971, Strippable Reserves of Bituminous Coal and Lignite in the United States. U.S. Bureau of Mines Information Circular 8531, 148 p.

.U.S. Bureau of Mines, 1975, The Reserve Base of U.S. Coals by Sulfur Content: Part 2, The Western States, Information Circular 8693.

Arizona

Unknown

Colorado

The CGS and the USGS have compiled many publications on coal resources and reserve estimates for Colorado. EIA presumably used the values compiled by Landis to calculate coal reserves up to 1997 on a bed by bed calculation by township. The CGS currently has no digital information from that study.

Montana

We do not know. The assumption is that "they" used the Averitt resource figure and then reduced it for mining restrictions.

New Mexico

The 1994 DOE- DRB study done by NM Bureau of Geology.

North Dakota

I have not seen that number before, but it is ridiculously low for not only the resource number but even for the reserves number.

Utah

We don't know the source. EIA lists the base year for the 1997 DRB data for Utah as 1971, so it must predate Doelling's work for the UGS. We believe that the DRB data for Utah are dated and could be improved with updated information from published and unpublished recent coal availability studies and other general coal resource studies that have been carried out since 1971.

Wyoming

Glass, Gary, B., and Jones, Richard, W., Coal Fields and Coal Beds of Wyoming, Wyoming State Geological Survey, Reprint No. 47, 1992.

6. What is the source (published or unpublished) of the most recent comprehensive coal resource estimate for your state?

Appalachian

Alabama

Ward, W. E., 1984, Reserve base of bituminous coal and lignite in Alabama: Alabama Geological Survey Circular 118, 102 p.

Kentucky

Brant, R. A., 1983, Coal Resources of the Princess District, Kentucky. University of Kentucky Institute for Mining and Minerals Research, Energy Resource Series, 61 p.
Brant, R. A., 1983, Coal Resources of the Southwestern District, Kentucky. University of Kentucky Institute for Mining and Minerals Research, Energy Resource Series, 89 p.
Brant, R. A., Chesnut, D. R., Frankie, W. T., and Portig, E. R., 1983, Coal Resources of the Big Sandy District, Kentucky. University of Kentucky Institute for Mining and Minerals Research, Energy Resource Series, 47 p.
Brant, R. A., Chesnut, D. R., Frankie, W. T., and Portig, E. R., 1983, Coal Resources of the Hazard District, Kentucky. University of Kentucky Institute for Mining and Minerals Research, Energy Resource Series, 49 p.
Brant, R. A., Chesnut, D. R., Frankie, W. T., and Portig, E. R., 1983, Coal Resources of the Licking River District, Kentucky. University of Kentucky Institute for Mining and Minerals Research, Energy Resource Series, 57 p.
Brant, R. A., Chesnut, D. R. and Smath, R. A., 1983, Coal Resources of the Upper Cumberland District, Kentucky. University of Kentucky Institute for Mining and Minerals Research, Energy Resource Series, 41 p.

The following, more recent assessments were completed for only selected coal beds:

Tewalt, S.J., Ruppert, L.F., Bragg, L.J., Weisenfluh, G.A., Thacker, E.E., Sites, R.S., Blake, B.M., Jr., Freeman, P.A., Bryant, L.C., and Butler, D.T., A digital resource model of the Middle Pennsylvanian Fire Clay coal zone, Pottsville Group, Central Appalachian Basin coal region, Chapter F, in Northern and Central Appalachian Basin Coal Regions Assessment Team, 2002 Resource Assessment of Selected Coal Beds and Zones in the Northern and Central Appalachian Basin Coal Regions: USGS Professional Paper 1625-C, 2 CD-ROM's.

Ruppert, L.F., Tewalt, S.J., Bragg, L.J., Weisenfluh, G.A., Thacker, E.E., Blake, B.M., Jr., Sites, R.S., Freeman, P.A., Butler, D.T., and Bryant, L.C., A digital resource model of the Middle Pennsylvanian Pond Creek coal zone, Pottsville Group, Central Appalachian Basin coal region, Chapter G, in Northern and Central Appalachian Basin Coal Regions Assessment Team, 2002 Resource Assessment of Selected Coal Beds and Zones in the Northern and Central Appalachian Basin Coal Regions: USGS Professional Paper 1625-C, 2 CD-ROM's.

Pennsylvania

Edmunds, William E., 1970 Coal reserves of Pennsylvania: Total, Recoverable and Strippable (January 1, 1970), Commonwealth of Pennsylvania, Bureau of Topographic and Geologic Survey. Harrisburg, PA . 40 p. (U.S.G.S National Coal Assessment. 2000 Resource Assessment of Selected Coal Beds and Zones in the Northern and Central Appalachian Basin Coal Regions. Pittsburgh and Upper Freeport Coals only.)

Virginia

No response.

6. What is the source (published or unpublished) of the most recent comprehensive coal resource estimate for your state?

West Virginia

In progress. See #3 above.

Interior

Illinois

Our most recent resource estimates are based on the Coal Availability studies from 1994 through 2003 (208 Billion Tons of identified resources, of which 96 billion tons are considered available). The seams assessed by the Coal Availability studies account for approximately 98% of the total remaining identified resources for Illinois—a total of 211 Billion Tons. The quoted figure of 211 Billion Tons adds minor seams to the 208 billion tons figure. Our remaining identified resource numbers were revised for the Keystone report in 6/2002 (published in 2003 volume, table listed 1998 [sic]. Recent mapping has updated the resource figures to 211 billion tons and are as-of-yet unpublished in Keystone).

Indiana

Mastalerz, et al., 2004, Open File Study 04-02 . This study uses previous evaluations by Conolly (Conolly, C., 2001. The availability of the Seelyville Coal Member for mining in Indiana. Indiana Geological Survey Open-File Study 01-8, Indiana Geological Survey, Bloomington, 52 p. Conolly, C.L., and Zlotin, A., 1999. The availability of the Springfield Coal Member for mining in Indiana. Indiana Geological Survey Open-File Study 99-7, Indiana Geological Survey, Bloomington, 49 p. Conolly, C.L., and Zlotin, A., 2000. The availability of the Danville Coal Member for mining in Indiana. Indiana Geological Survey Open-File Study 2000-1, Indiana Geological Survey, Bloomington, 47 p., and also provided new evaluations for several coal beds.

Kansas

The USGS-NCRDS program helped support this work. The deep coal study (100+ feet deep) was conducted in the mid-1980's and totaled 53,534 million tons. This work was completed using underground coal mine maps, company coal drilling records, but mainly using geophysical logs from oil and gas tests. First reported Brady and Livingston 1989; with a deep coal resource in table form published by Brady (1990, p. 117).

Brady, L.L., and Livingston, N.D., 1989, Deep coal resources in the Cherokee Group (Middle Pennsylvanian) in eastern Kansas [Abstract]: American Association of Petroleum Geologists Bulletin, v. 73, p. 336-337. Brady, L.L., 1990, Kansas coal resources and their potential for utilization in the near future; in Coal Geology of the Interior Coal Region--Western Region: Guidebook for the 1990 Geological Society of America Coal Geology Division Field Trip, Oct. 26-28, 1990, p. 107-127.

Kentucky

Smith, G. E., and Brant, R. A., 1980, Western Kentucky Coal Resources. University of Kentucky Institute for Mining and Minerals Research, Energy Resources Series, 148p.

The following, more recent assessments were completed for only selected coal beds:

G.A. Weisenfluh, W.M. Andrews Jr., R.E. Andrews, and J.K. Hiatt , 2001, Coal Availability in Western Kentucky: Kentucky Geological Survey, ser. 12, Report of Investigations 8, 29 p.

Hatch, J.R. and Affolter, R.H., 2002, Resource assessment of the Springfield, Danville, and Baker coals in the Illinois Basin: USGS Professional Paper 1625-D, 2 CDROMS.

6. What is the source (published or unpublished) of the most recent comprehensive coal resource estimate for your state?

Louisiana

There isn't a current one, as new data has been developed since the last one was done.

Mississippi

Industry estimates published in: Luppens, James A., and Michael B. E. Bograd, 1994, Mississippi Lignite a valuable energy source: Mississippi Geology, vol. 15 (4), 58-63. (Total lignite resources for the state in lignite beds 2 feet thick or greater and less than 200 feet in depth are 5 billion tons).

Missouri

The most recent publication is Coal Resources and Reserves of Missouri by Charles Robertson and David Smith. This is a Missouri Department of Natural Resources publication (Report of Investigations Number 66).

Western

Alaska

Flores, R.M., Stricker, G.D., and Kinney, S.A., 2004, Alaska coal geology, resources, and coalbed methane potential, U.S. Geological Survey Digital Data Series DDS-0077, CD-ROM and Stricker, G.D., 1991, Economic Alaskan coal deposits, in Gluskoter, H.J, Rice, D.D., and Taylor, R.B., (eds) The Geology of North America, P-2, Geological Society of America, Boulder, CO, p. 591-602.

Arizona

USGS Professional Paper 1625-B
AZ Bureau of Mines Bulletin 182

Colorado

I like to include coal calculations for available coal in the areas we have worked. This would be available coal in active mining areas. Next, I use the DRB value from DOE/EIA because it is published. But since it has not been updated to include our two DRB coal studies, I have a modified DRB for Colorado at 20 billion. I do not use the coal resource values to 6000 ft deep because they include unmineable resources, which Colorado has plenty of. The best source is the USGS Landis (1959) for original coal values for the entire state.

Montana

Averitt, Paul, 1975, Coal resources of the United States, January 1, 1974: U.S. Geol. Survey Bulletin 1412, 131 p. Averitt's compilation indicates a 291,600 million ton identified resource for Montana, and is the figure quoted in the Keystone publication. A more recent government contractor's report would increase this figure significantly, but we do not use it.

New Mexico

The DOE/ DRB study is the most comprehensive for state at this time; completed in 1994. Since that time, several individual coal availability studies - for the USGS-have

been completed in the San Juan and Raton basins using 4 7.5 min quadrangle study areas. The DOE was done before we used GIS in resource calculations and needs to be updated to subtract for recent production. (see attached references).

6. What is the source (published or unpublished) of the most recent comprehensive coal resource estimate for your state?

North Dakota

North Dakota Geological Survey publications :

Murphy, E.C., 2001, Strippable lignite deposits of North Dakota: North Dakota Geological Survey Miscellaneous Map No. 34.

Murphy, E.C., Kruger, N.W., Goven, G.E., Vandal, Q.L., Tudor, E.A., in prep, The coal resources and reserves of North Dakota: North Dakota Geological Survey Report of Investigation No. 104, pp.

Murphy, 2001 estimated ND reserves at 25.1 billion. Murphy, et al, in prep, estimates ND resources at 1.3 trillion tons.

Utah

Doelling's (1972) three monographs for the UGS were the last comprehensive state-wide coal resource estimate. With funding from the USGS, the UGS has completed coal availability studies of the three producing coalfields in Utah; these studies provide an updated look at resources in those fields (Book Cliffs, Emery, and Wasatch Plateau). We are continuing a slow re-inventory of other coalfields with funding from the USGS NCRDS program; currently working on the Alton coalfield, with future plans to do the Henry Mountains, Sego, and Salina Canyon coalfields. There are 22 coalfields in the state.

Wyoming

Glass, Gary, B., and Jones, Richard, W., Coal Fields and Coal Beds of Wyoming, Wyoming State Geological Survey, Reprint No. 47, 1992. Current work in progress by the WSGS is collecting and modeling coal occurrence data within the PRB. Results and publications from this work are an online interactive coal model (<http://ims.wrds.uwvo.edu/prb/index.html>), open-file series of individual economic coal seams, and minable resource reports.

5. What factors might impede increasing coal production?

Appalachian

Alabama

Limited acreage available for longwall mining, declining surface reserves, heterogeneous land ownership in frontier areas, higher sulfur content and lower calorific value of coal in frontier areas.

Kentucky

Shortage of qualified, experienced miners, shortages of raw materials (equipment

and steel materials), lengthy permit process.

Pennsylvania

Environmental regulations and permitting requirements (including lengthy approval process), access to deep reserves, urban development and equipment availability.

Virginia

Concerns for underground miner safety.

West Virginia

Some factors that have been challenges to increased production in the recent up-swing in demand include: shortage of experienced miners; permitting backlogs; increased environmental and safety requirements; transportation bottlenecks; shortage of supplies (for example tires for large equipment); and increasing technological challenges associated with a mature coal field such as working in areas that have been mined above and beneath, smaller reserve blocks, and thinner (although not necessarily lower quality) and deeper remaining coal.

Interior

Illinois

This is more an economic and social question than a technical-geologic one for Illinois. Again, according to informal conversations with the coal industry, the lack of skilled, experienced manpower could very well be the largest impediment. Many miners moved on during the slump of the 80s and 90s. We see this, too, in the lack of available coal geologists.

Indiana

Mining capacity, environmental restriction, coal prices.

Kansas

Thin coal beds, environmental regulations for coal consumption, and competition with western coal--specifically from Wyoming for the Kansas and eastern Missouri markets.

Kentucky

The coal's moderate to high sulfur content. Increased mining costs for developing coal at depths greater than 1000 feet and in proximity to faulted areas.

5. What factors might impede increasing coal production?

Louisiana

Permitting and environmental issues.

Mississippi

Demand for the electricity produced, price.

Missouri

Factors possibly impeding coal production in Missouri are available rail transportation, cost of mine reclamation, and locating markets for Missouri coal.

Western

Alaska

Lack of infrastructure (question 4) and potential delays in permitting for mining operations could potentially impede increasing coal production.

Arizona

Environmental factors, principally water supply.

Colorado

The Moffat Tunnel was built in 1927. It is a 6.4 mile long tunnel beneath the Continental Divide and is the only corridor for rail traffic from western Colorado to the east. Over twenty coal trains per day pass through the Moffat Tunnel. The UP coal director also said that a new tunnel today would cost more than \$500 million to build. Other factors in the next 20 years include the implementation of the CAIR II & III regulations for power plants in the U.S. By 2015, if the power plants that use Colorado coal today retrofit with scrubbers, then the demand for compliant Colorado coal may decrease.

Montana

Lack of rail transportation, and most importantly the success of anti-mining groups in the State.

New Mexico

Lack of transportation infrastructure in the San Juan Basin is the major impediment along with checkerboard ownership – Federal-State- Native American/Tribal lands.

North Dakota

Transmission line capacity in both North Dakota and Minnesota.

Utah

Significant amounts of coal resources in Utah are off limits to development by inclusion in national monuments, BLM wilderness study areas, and USFS roadless areas. There has also been a tendency to add more environmental restrictions over time such as the definition of Areas of Critical Environmental Concern, new areas with wilderness characteristics, and other factors that make mining and exploration in Utah more and more difficult and expensive, even in areas with extensive histories of mining.

5. What factors might impede increasing coal production?

Wyoming

This past year rail transportation capacity out of Wyoming showed that it is approaching its threshold. With respect to rail transportation, Wyoming's annual coal production may show an increase of an additional 100 million tons by 2010, this would boost annual production in excess of 500 million tons per year from Wyoming's PRB. As for the APC

recently proposed coal-fired power plants in Wyoming had to step down projected power output in order to leave room under the total APC for other energy industries such as new mines, gasification and liquefaction plants, and oil and gas development. The current combined APC for coal operators in Wyoming's Powder River Basin is roughly 600 million tons per year.

4. If coal demand increased two-fold (presumably with an associated rise in prices) do you feel that your state could significantly increase production to meet that demand?

Appalachian

Alabama

Yes. However, the length of time that doubled production could be sustained is uncertain. Furthermore, doubling production would require development of resources not currently in the DRB in about a decade. Doubling of prices would support mining of thinner coal than is currently considered prospective by operators of longwall mines.

Kentucky

It is unlikely that coal production could be doubled in eastern Kentucky.

Pennsylvania

If the demand (and associated price) increased two-fold the statewide production would increase on the order of 10-25%. Doubling production in Pennsylvania would be nearly impossible, at least in a short-term (5 year +/-) scenario.

Virginia

Difficulty in maintaining an adequately trained work force may hinder significant production increases.

West Virginia

West Virginia has abundant coal resources and a robust and talented industry that has consistently met the challenges of changing operating environments and markets. Production in West Virginia climbed steadily through the 1980s and 90s and reached a record of 191,914,000 tons in 1997, exceeding the old record set in the immediate post World War II period. While underground production also rose, much of the production gain came from large surface mines (mountaintop removal mines). Total production then dropped to 145,899,599 tons in 2003, but is rebounding, expected to approach 160,000,000 tons for 2005. The challenges outlined in #5 below are impacting the ability of the industry to respond to current rising prices and demand, but recent gains in production indicate the industry continues to adjust and succeed. New demand probably will be created by scrubber installation in power plants and could very well be met by additional or accelerated production from higher sulfur resources in northern West Virginia. A sustained and steady rise in demand and prices would lead to greater resolve and resources to meet all challenges and increase production.

Interior

Illinois

This question falls outside our area of expertise. Anecdotal information gathered from speaking to coal companies and others in the industry indicate workforce issues may be the biggest impediment to meeting increased demand. The number of Illinois mines are down to about half of what they were in the early 1980's (and annual tons mined are also about half). According to a few companies we have talked to, the number of available miners (experienced and otherwise) is small compared to the needs already existing at several mines in the state. From a geologic perspective, however, there is no reason why production could not be increased two-fold.

Indiana

With regard to coal volumes, yes, with regards to mining capacity, no.

4. If coal demand increased two-fold (presumably with an associated rise in prices) do you feel that your state could significantly increase production to meet that demand?

Kansas

Yes

Kentucky

There is a sufficient amount of western Kentucky underground resources to double coal production.

Louisiana

Yes

Mississippi

Mississippi reserves could support greater than a two-fold production increase, but only with the opening of additional mines.

Missouri

Yes, Missouri has an estimated 4.9 billion short tons of recoverable reserves.

Western

Alaska

Alaska lacks infrastructure for coal transportation and export with the exception of the railbelt and marine coal terminal in Seward for shipping. Usibelli Coal Mine could likely double its production of coal resources. If the demand was great enough, tidewater coal such as the Beluga-Capps and Deadfall Syncline coal fields could begin mining.

Arizona

Absolutely. In fact, the largest mine is operating at greatly reduced capacity due to

loss of its major market at the end of 2005.

Colorado

No. Colorado coal mines have already doubled their production output since 1984. This was more than twice the rate predicted by the CGS in 1984. This is increase in Colorado coal production resulted from implementation of the Clean Air Act of 1990, when our low sulfur, high Btu coal became in high demand for power plants in the Eastern US. Consequently, at 40 million tons per year, the Colorado coal mines are nearing the capacity utilization for the very narrow train corridor through the Moffat tunnel. The coal director for the Union Pacific (UP) Railroad told me last week that they can only handle up to 40 million tons per year transported in Colorado. The only way that Colorado coal mines could increase to 80 million tons per year would be through mine-mouth power plants around the state.

Montana

In terms of reserves/resources, most definitely.

New Mexico

It is possible given the increase in price, particularly along the Fruitland trend where there was so much exploration activity in the mid 1970's.

4. If coal demand increased two-fold (presumably with an associated rise in prices) do you feel that your state could significantly increase production to meet that demand?

North Dakota

Very easily from the mining standpoint, but building power plants would take time and transmission line capacity would have to be significantly increased.

Utah

Coal production could probably be increased in Utah by maybe 20 to 25%, but we would have a hard time doubling production and sustaining that level for any prolonged period.

Wyoming

Yes, Wyoming's annual coal production has doubled every 10 years since commercial mining began in the PRB during the 1970's. With this in mind, 10 years from now production is expected to exceed 600 million tons. Realistically, Wyoming's future annual production increases will be governed by two major factors; rail capacity and Air Permit Capacity, (APC). Once these issues are resolved utilization and production of Wyoming coal will increase dramatically.

3. Do you feel that Identified Resources, the DRB, or another methodology most closely represents the coal in your state that would be available for mining in the next two decades?

Appalachian

Alabama

The DRB for Alabama, although conservative, is representative of what is being surface-mined in Alabama. However, as already mentioned, reserves that were considered inferred at the time the DRB was determined now constitute a major part of the state's production.

Kentucky

The DRB underground figure (1.2 BT) is probably off by an order of magnitude. More recent coal studies show 6.5 BT remaining coal in just four coal beds, and much of this would be underground mineable.

The DRB surface figure (9.4 BT) appears to be much too high, however KGS does not have a comprehensive estimate of surface mineable coal.

At the same time, the Keystone "Identified Remaining Resource" of 53 BT likely contains much thin coal that will not be mineable by underground methods.

Pennsylvania

The U.S.G.S coal availability methodology would more closely approximate potentially mineable resources.

Virginia

The DRB estimate produced by the EIA is representative of the coal resources in Virginia.

West Virginia

The West Virginia Geological and Economic Survey is currently remapping all coal in the state utilizing Geographic Information System (GIS) technology (called the Coal Bed Mapping Project). We are just beginning the process of resource and reserve estimates from this mapping. The county-by-county estimates we make will best represent the amount of coal that would be available for mining in the next two decades. Preliminary results for one county identify about 35% more Identified Resources when compared with the estimate made in 1913. Of course, considerable mining has taken place in this county in the interim. Any nation-wide methodology that is clear, workable, and allows meaningful comparison with other states would be acceptable, like USGS Circular 891, Coal Resources Classification System of the U.S. Geological Survey. In addition, emphasis needs to be placed on programs and personnel to assess how much of the Identified Resources or the DRB are reserves in the strict sense of the word: they can be mined in the current market. For now in West Virginia the Identified Resources and the DRB are the best information available, are related to one another (see #1), and are both useful, as long as the user understands the origin of these estimates.

Interior

Illinois

The criteria in our Coal Availability studies mentioned above most closely delineate coal available for mining.

3. Do you feel that Identified Resources, the DRB, or another methodology most closely represents the coal in your state that would be available for mining in the next two decades?

Indiana

The most current evaluation available from the IGS is most accurate, and the coal volumes in the DRB should be revised for Indiana.

Kansas

The DRB amount best represents the coal available in Kansas for strip-mining. Only strip-mining is presently used for the mining of coal in Kansas and this will probably continue for the foreseeable future. The last deep mining for coal in Kansas was in the early 1960's.

Kentucky

The DRB underground estimate of 15.9 BT is probably close to the amount of coal that could be mined. The estimate of 3.6 BT for surface mineable coal is considered to be too high. Surface mining has diminished continually since the 1970's, and this is thought to be related to depletion of near-surface resources.

Louisiana

Identified resources.

Mississippi

Not applicable. No Identified Resources are given for Mississippi, although there currently is production and there are extensive reserves of lignite.

Missouri

The Identified Resources published in 2002 would likely be the most accurate estimate.

Western

Alaska

It is not clear how the DRB was calculated for Alaska. An updated version of the Identified resources would more accurately reflect Alaska's available for mining coal resources. This assessment should be conducted by or reviewed by people familiar with Alaskan coal resources.

Arizona

Coal reserves determined by Peirce et al (1970, Coal, oil, natural gas, helium, and uranium in Arizona, Arizona Bureau of Mines, Bulletin 182, 289p.) are 21,250 million short tons. The methodologies in current use appear to be oblivious to these data.

Colorado

Since the CGS has been an active participant in the USGS Coal Availability program, we feel that about 80 percent of the active coal mining regions have been studied. Coal availability is defined as original coal minus depletion, land use restrictions, technological restrictions, or essentially about 2/3 of the identified resources. It very closely approximates that coal which is being mined today and that which will be mined in the next two decades. Coal Availability is a strong representation for mineable coal in

the immediate future. The coal recoverability studies conducted by the USGS are also very good approximations for mineable coal because they use economic criteria not established in the availability studies.

3. Do you feel that Identified Resources, the DRB, or another methodology most closely represents the coal in your state that would be available for mining in the next two decades?

Montana

By Identified resources" are you referring to the Keystone numbers? Our feeling is that the more conservative DRB numbers adequately reflect what we will be mining over the next several decades. We do not need to stretch into the identified resources at this point.

New Mexico

In the case of the NM Identified Resource table in Keystone, the data is a combination of information from the DRB and other resources. Specifically, the deep coal data is from another source that goes to greater depths than 1000 ft. I do not necessarily think coal at greater than 1000 ft will be mined; rather it has CO2 potential. I tend to think the 250 f depth for surface mining is more realistic, but the minimum cutoff of 2.5 used in the DRB is probably more in line with actual practices than 2 ft, which was used in the Identified resources.

North Dakota

The North Dakota Geological Survey's estimated reserves of 25 million were generated from a significant database (20,000 holes) using economic criteria being used by coal companies currently operating in North Dakota (minimum thickness of 10 feet of coal occurring in two or less beds, deeper than 25 feet but no deeper than 170 feet, no more than a 10:1 stripping ratio, minimum bed thickness of 2.5 feet. All of the 25 billion tons that have been identified could potentially be mined within the next 20 years.

Utah

The BLM, which administers the leasing of most of the coal in Utah, has data adequacy requirements before any tract can be leased to assure fair market value is achieved on sale of a lease. Since the BLM requires that at least 80% of the coal in a tract to be leased to be demonstrated in reliability, then the DRB, if properly calculated and updated should be a good estimate. The only problem would be in areas that we can reasonably assume will be mined in the next two decades based on their location, that have slightly less data than needed to be classified as demonstrated, and these would not be included in the DRB.

Wyoming

The reported 1978 DRB for Wyoming represents a minimum value. Since most of the coal deposits that are commercially mined fall under federal mineral ownership, coal companies bid for minable acreages under a Lease By Application process or LBA. Current tonnages under existing LBAs only represent a small portion (approximately 12%) of the reported DRB for Wyoming. This is enough to sustain an annual production of 400 million tons for the next 20 years.

9. How are coal production statistics compiled for your state?

Appalachian

Alabama

Companies report production data to the Alabama Department of Industrial Relations.

Kentucky

Coal production tonnages are reported to the Office of Mine Liscensing and Safety. Companies also submit mine maps and reserve data to the Kentucky Revenue Cabinet.

Pennsylvania

They are compiled by the Department of Environmental Protection, Bureau of Mining and Reclamation. They provide forms to all active coal companies.

Virginia

Annual reports to the VA Dept. of Mines, Minerals and Energy. The VA Division of Mineral Resources compiles data from these reports. Latest compilation is contained in Open-File report 05-04 "Mineral and Fossil Fuel Production in VA 1999 - 2003".

West Virginia

Operating mines report production to a sister state agency, the West Virginia Office of Miners' Health, Safety, and Training. They have excellent records going back to their inception in 1883 and further to when West Virginia became a state in 1863.

Interior

Illinois

Currently, the Illinois Office of Mines and Minerals (part of Illinois Department of Natural Resources in Springfield) compiles annual statistics.

Indiana

The IGS does not collect that data, however 2 state agencies do: 1) Indiana Bureau of Mines and Mining is required to collect production data, but companies are not required to respond so some estimations are made. 2) Indiana Division of Reclamation - Coal reclamation fees are based on production so they collect those data. They are probably more reliable for that reason. The US Department of Labor Mine Safety and Health Administration (MSHA) also collects production data and reports it to the US Department of Energy, Energy Information Administration. On occasion we use those federal numbers.

Kansas

Coal companies operating in Kansas send their production statistics to the: Surface Mining Section:

Kansas Department of Health and Environment
4033 Parkview Drive

Frontenac, KS 66763

The Surface Mining Section then compiles the coal production tonnages for the state.

9. How are coal production statistics compiled for your state?

Kentucky

Coal production tonnages are reported to the Office of Mine Liscensing and Safety. Companies also submit mine maps and reserve data to the Kentucky Revenue Cabinet.

Louisiana

They are no longer compiled, to the best of my knowledge. The geologist performing that function was reassigned. Coal production statistics are the responsibility of the Louisiana Department of Natural Resources, Injection and Mining Division.

Mississippi

From the production records at the only mine in the state.

Missouri

They are compiled by the Missouri Department of Labor and Industrial Relations/Division of Labor Standards/Mine Safety and Health Training Program.

Western

Alaska

Annual coal production data for Alaska is provided directly by the sole producer, Usibelli Coal Mine, to the State of Alaska.

Arizona

Unknown

Colorado

The Colorado Division of Minerals and Geology is the regulatory agency charged with this task. They have the coal mine operators report monthly coal production for each mine. Annual and monthly data can be retrieved from the web at <http://mining.state.co.us/Coal%20Reports.htm>.

Montana

Companies must submit their production figures to the Montana Dept of Revenue. Updates are provided monthly.

New Mexico

Production stats are compiled by the New Mexico Energy, Minerals and Natural Resources Dept., Mining and Minerals Division in Santa Fe. Contact - John Pfeil | JPfeil@slate.nm.us.

North Dakota

Compiled by the North Dakota State Tax Department.

Utah

We have coal production statistic by statewide, as well as broken down by coalfield and county. There is individual mine production data available from MSHA dating back to 1978, and from various sources we have partial individual mine production data extending back to 1897. The State Energy Office and UGS have cooperated to compile and report on Utah coal production and distribution (Annual Coal Report) dating back to at least 1989.

9. How are coal production statistics compiled for your state?

Wyoming

Coal production in Wyoming is tracked by several agencies: Wyoming Department of Revenue, Wyoming State Mine Inspector's Office, Wyoming Mining Association, Wyoming BLM, and the Wyoming State Geological Survey. All of these agencies compile information from individual mine companies and the Federal Energy Regulatory Commission (FERC form 423). Results are then compared and published in the Wyoming State Mine Inspector's Annual Report.

14. If so, describe the methodology for applying quality to resources.

Appalachian

Alabama

Not applicable.

Kentucky

N/A

Pennsylvania

N/A

Virginia

no response.

West Virginia

We will attempt to categorize tonnages estimated under the Coal Bed Mapping Project by either utilizing raster calculations or by simply reporting the range of quality parameters likely to be found for each bed based on all of the sample analyses available or based only those located in the remaining resource area, if a sufficient number exist.

Interior

Illinois

Where coal quality parameters have been mapped, GIS selections delineate resources that have available coal of a certain quality. For example, based on empirical evidence, we identify low to medium sulfur areas as where the immediate roof rock has 20 feet or more of non-marine (usually gray shale and mudstone) versus marine rock (black shale and limestone). Non-marine roof rock directly on the coal seam greater than 20 feet in Illinois correlates strongly with low to medium sulfur content in the coal. The low to medium sulfur available coal category results from the geographic intersection of areas meeting the roof rock composition criteria with areas showing 'available coal'. These may be modified by measured coal quality data.

Indiana

N/A

Kansas

See above (Item 13)

Kentucky

N/A

Louisiana

N/A

Mississippi

See no. 10.

14. If so, describe the methodology for applying quality to resources.

Missouri

NA

Western

Alaska

Coal resources are categorized by the basic coal quality parameter of rank when known.

Arizona

NA

Colorado

In the two DRB studies we segregated coal resources by heat value (8500-10000, 10000-11500, 11500-13000, > 13000 Btu); sulfur (<0.40, 0.41-0.6, 0.61-0.83, 0.84-1.24, 1.25-1.67, 1.68-2.5, > 2.5 LBS/mBtu); ash (0-5, 5-10, 10-15, >15 percent).

Montana

The Powder River Basin coals are uniform enough that it's not a huge problem at this point.

New Mexico

In general weighted averages are used either on a formational or member basis. For the availability studies were weighted averages applied to correlated coal zones.

North Dakota

NA

Utah

We hope to use our GIS resource studies to assign coal quality to the beds we have been able to map in the Alton, Book Cliffs, Emery, and Wasatch Plateau coalfields, as well as any other future coalfield studies.

Wyoming

Not Applicable

13. Are your estimates categorized by basic coal quality parameters?

Appalachian

Alabama

No

Kentucky

No.

Pennsylvania

No

Virginia

Generally no, although basic coal quality parameters are monitored.

West Virginia

The reconnaissance estimate of original resources made by the West Virginia Geological and Economic Survey is not categorized by coal quality, although analyses for the various coal beds are tabulated and averages reported.

Interior

Illinois

To an extent, yes. A category for low to medium sulfur available coal exists within our GIS tabulations and is indicated in our Herrin and Springfield Coal Availability studies.

Indiana

No, coal quality is not part of the resource estimate.

Kansas

No. All Kansas coal resources are bituminous, and most are high sulfur. Some coal quality data was determined and compiled with cooperation with USGS.

Kentucky

No.

Louisiana

Not to my knowledge.

Mississippi

See no. 10.

Missouri

No, the estimates were reported with the understanding that coal quality could vary between basic quality parameters.

13. Are your estimates categorized by basic coal quality parameters?

Western

Alaska

Yes. Basic coal quality parameter of Rank when known.

Arizona

No

Colorado

Yes, for the DRB studies, but no for the coal availability studies. For the two DRB studies we worked on, we implemented coal quality (Btu, ash, sulfur) information into the model. Divisions of quality were not widely varied using the DOE/EIA national criteria because 97 percent of Colorado's coal falls within the compliance coal categories. The Coal availability studies do not segregate resources by quality, but we provide the follow-up USGS coal recoverability studies with NCRDS coal quality data for those study areas. Coal availability only uses coal rank for coal density information.

Montana

A qualified yes. Our recent work is mostly limited to parts of the Powder River Basin and coal quality is relatively uniform. However, the deposits within the Powder River Basin do

have some variation in quality and we have reserve figures for those individual deposits. Most of the publicly available quality data are from coals already mined.

New Mexico

Yes, in major coal areas where there is adequate coal quality data.

North Dakota

We have little or no coal chemistry in our database.

Utah

We know the average rank, heat, ash, and sulfur contents of the coal in each coalfield, but we do not have a resource breakdown on this basis. Some of the individual coal beds do have enough data to attempt a resource estimate breakdown by basic coal quality parameters, but not all coal beds have adequate data on coal quality to make a uniform comprehensive statewide resource breakdown. We hope to do more refinement of our resource estimates by coal quality in the future.

Wyoming

No, at this phase of coal resource estimation, identifying changes in coal quality is an unnecessary parameter because of the uniform consistency over distance of Wyoming's economic coal deposits. Also, previous coal quality analysis provides adequate base-line data for each of Wyoming's coal bearing basins. During later stages of coal reserve assessment, coal quality is assessed regularly by both coal operators and the BLM. The majority of Wyoming's coal falls into the federal mineral estate and therefore coal analysis is conducted by federal agencies.

12. If so, what basic methods were used to estimate overburden (e.g., GIS, manual contouring or mapping)?

Appalachian

Alabama

Manual contouring.

Kentucky

GRID analysis in GIS, and manual contouring of posted data.

Pennsylvania

Manuel contouring.

Virginia

Overburden estimates based on GIS, structural contours, and 3-dimensional modeling (in development).

West Virginia

The Coal Bed Mapping Project will utilize raster calculations in GIS to categorize the tonnage estimates by overburden depth or ratio.

Interior

Illinois

As with all aspects of our recent Coal Availability work (and even the DRB work in 1997), we have been doing all our resource work in a GIS-based environment—historically ArcInfo and currently ArcGIS (both ESRI products). Hand-drafting, contour adjustments and editing via the GIS is done to augment digital inputs and outputs as needed.

Indiana

GIS

Kansas

The deep coal resources can be divided by depth categories using GIS. The strippable coals were determined by hand methods using hand planimeter, and hand contour and mapping.

Kentucky

Manual contouring. More recent studies use GIS methods of deriving overburden thickness.

Louisiana

N/A

Mississippi

See no. 10.

12. If so, what basic methods were used to estimate overburden (e.g., GIS, manual contouring or mapping)?

Missouri

This is estimated by manual contouring.

Western

Alaska

The coal resource estimates were conducted by manual contouring methods (seeWahrhaftig and others, 1969).

Arizona

Probably manual contouring and mapping.

Colorado

We use ArcGIS 9.1 to create overburden maps on a bed by bed basis. These are

available for seven coal fields around Colorado, but not for the entire state. We use digital mapping and subtract the modeled subsurface values of the coal beds from a Digital Elevation Model (DEM). Typically we use the 30-meter data for studies of about 25 quadrangles in size. We have the ten-meter data also but only use it for studies on the order of one or two quadrangles in size.

Montana

It depends on the vintage of the work. Our most recent work used GIS. In the several decades before that it was probably based on both mapping and manual contouring. Prior to that, who knows what the USGS did.

New Mexico

Manual contouring and mapping in the past, GIS with DEMS more recently.

North Dakota

All of the data points (drill holes with geophysical logs) were plotted on 1:24,000 scale (quadrangles), coal beds were correlated across the area, thicknesses were averaged, and mining limits were hand contoured. These maps are now in the process of being scanned into ArcInfo. Drill hole data has been supplied to the NCRDS.

Utah

Doelling's study used manual mapping methods, while the recent coal availability studies employed GIS mapping techniques.

Wyoming

Once coal seam tops and bottoms were identified and collected from geophysical well logs, they were correlated using RockWorks 2002 and 2004. Utilization of ArcGIS was crucial to verifying well locations and was also used to generate coal isopach, coal structure, and overburden maps.

11. Do your estimates include categorization by depth?

Appalachian

Alabama

Yes

Kentucky

Not for the Brant studies. More recent coal availability and National Coal Resource Assessment work does for selected beds and specific areas.

Pennsylvania

Strip vs. deep (only other than the U.S.G.S. report on the Pittsburgh and Upper Freeport seams).

Virginia

By coal bed.

West Virginia

The reconnaissance estimate of original resources made by the West Virginia Geological and Economic Survey is not categorized by depth. The Coal Bed Mapping Project estimates will be categorized by depth or overburden ratio (cubic yards to tons, preferred).

Interior

Illinois

Yes, depth is one of our classifications to separate surface from underground minable coal, in both our recent (Coal Availability) and past (DRB) research studies.

Indiana

Yes

Kansas

Deep coal is limited to 100-2500 ft. Resources are not divided into depth categories. Strippable coal limited to 100 ft depth. – These resources include 0-50 and 50-100 ft depths, and also resource numbers based on a 30:1 stripping ratio.

Kentucky

Yes, the Smith and Brant study used 150 feet as the limit of surface minable resources.

Louisiana

Not to my knowledge.

Mississippi

See no. 10.

Missouri

Yes, they include estimated overburden thickness.

11. Do your estimates include categorization by depth?

Western

Alaska

No.

Arizona

Yes (Peirce et al, 1970)

Colorado

Yes, our availability studies include volumetric estimates by depth, thickness, and reliability indicators. For any particular basin, we calculate coal resources to 2,500 ft deep, based on the fact that the deepest coal mining in Colorado today is over 2,300 ft deep.

Montana

Our own estimates do, and presumably the state-wide estimates done by others do also.

New Mexico

Yes, in most cases estimates are done by depth.

North Dakota

The reserves have a maximum depth of between 150 and 170 feet while the resource estimates have no depth limit or depth categories.

Utah

Yes, both Doelling's estimates and more recent coal availability estimates include depth classes.

Wyoming

Yes, the classification between what are available coal resources and what is defined as coal reserves is determined by depth, thickness, and mining method. However, future work by the WSGS will focus on minable resources as a function of incremental strip-ratios up to a ratio of 10:1. The product of a serious effort in the late 1970's generated a series of coal resource reports for Wyoming's coal bearing basins that are today still very useful. The goal of the WSGS is to update and modify these reports based on the data that is presently available. These updated reports will include plates indicating overburden thickness.

10. What methods are used to adjust your in-place resource estimates for annual production (e.g., GIS, arithmetic subtraction from totals, etc.)?

Appalachian

Alabama

Arithmetic subtraction from totals.

Kentucky

Traditionally this was done arithmetically, doubling coal production to account for coal left in pillars or lost in mining and processing. More recent studies use GIS to subtract mined areas from original resource files.

Pennsylvania

Arithmetic subtraction from totals.

Virginia

Combination of GIS and simple math.

West Virginia

The reconnaissance estimate of original resources made by the West Virginia Geological and Economic Survey is debited by cumulative production plus a county-by-county estimate of lost-in-mining. The Coal Bed Mapping Project will utilize GIS to estimate coal mined and lost-in-mining by calculating how much coal is within digitized footprints of underground, surface, auger, and highwall mines. These amounts could be compared with cumulative production by county for underground and surface mining (auger and highwall mining are also reported as surface production).

Interior

Illinois

Current methods involve the use of ArcGIS software to adjust our in-place resources. Subtractions are based on keeping current (as much as possible) mined area boundaries in the GIS to make the most accurate assumptions about current depletion from mining. The ISGS works with the Office of Mines and Minerals and individual coal companies to ensure updates of our mine boundaries in the GIS are completed annually.

Indiana

GIS for our recent (post 1999) evaluation . For Keystone, arithmetic subtraction from totals; conservatively 80% recoverability for surface mines and 50% recoverability for UG. I was told that some companies only report salable products and others report everything they mine. Currently the IGS is using Indiana Bureau of Mines (IBM) data probably will use Division of Reclamation in future if IBM data are unavailable. The Division of Reclamation production reports are based on actual amount of coal sold.

Kansas

Because of low production quantities of coal in Kansas, the numbers are simply subtracted from the resource total.

10. What methods are used to adjust your in-place resource estimates for annual production (e.g., GIS, arithmetic subtraction from totals, etc.)?

Kentucky

Traditionally this was done arithmetically, doubling coal production to account for coal left in pillars or lost in mining and processing. More recent studies use GIS to subtract mined areas from original resource files.

Louisiana

Unknown.

Mississippi

Mississippi does not do this.

Missouri

The method used is arithmetic subtraction.

Western

Alaska

In-place coal resources are not adjusted for Alaska. The amount of coal mined is very small and Usibelli Coal Mine is currently mining in areas not included in the DRB.

Arizona

Unknown

Colorado

The CGS uses GIS technology for all coal availability studies. We do not calculate in-place resource estimates from remaining coal. To be consistent, I use the recoverable reserves and remaining demonstrated reserve values published by the DOE/EIA every year. Take note that if the DRB is not updated by around 2100, the DRB for Colorado coal will be zero.

Montana

Annual production of 40 million tons is so small in comparison with the stated reserves (ranging from -120 to 291 billion tons, depending on the source quoted) that the annual production hardly makes a difference in significant figures. Given the huge uncertainty in reserves, it hardly matters whether we bother to adjust in-place resource figures.

New Mexico

Because there are so few mines, four at the present, and they are all in different coalfields, the subtraction is done arithmetically. However, for the USGS availability studies where there was past or present mining, the amount was subtracted in GIS by area and depth.

North Dakota

Reserve estimate is four or five years old so we have not amended it – it would be a matter of subtracting 150 million tons or so from 25 billion tons.

10. What methods are used to adjust your in-place resource estimates for annual production (e.g., GIS, arithmetic subtraction from totals, etc.)?

Utah

For our statewide estimate, we start with Doelling's in-place numbers, reduce them by a recovery factor to estimate the recoverable coal and then subtract arithmetically the coal production recorded to arrive at estimates of the remaining recoverable coal state wide, as well as by coalfield and county. No subtractions are made for coal that is administratively inaccessible because of wilderness or monument designations.

For the coal availability studies, we used GIS methods to calculate the in-place resources, then subtracted out coal that is mined out by mapping mine workings, then removed coal that is restricted technically and for land-use/administrative reasons to arrive at the coal available for future mining.

Wyoming

Adjustments to the in-place resource estimates are made in database spreadsheets (subtraction from LBA numbers). The database serves as a geo-database that is utilized in our ArcGIS projects.

15. Do you feel that you have sufficient data to evaluate your resources by pertinent quality parameters?

Appalachian

Alabama

Yes

Kentucky

We have sufficient data to generally categorize coal beds into broad quality categories, but not to site specific mapping of quality.

Pennsylvania

In some areas and on some seams only. Most of the Pennsylvania Survey coal quality data are not digitized.

Virginia

Yes

West Virginia

The problem is that the distribution of sample locations is far less dense than that of thickness or elevation control for any given bed. For major beds we probably have enough analyses to accurately predict the likelihood that the value of a given quality parameter will fall within a particular range. However, we may not have many analyses that are actually located in the remaining resource areas.

Interior

Illinois

We feel confident on our low to medium sulfur category designation. Although we do have data on chlorine, mercury, and other trace elements, the coverage of the data is not as extensive as that for sulfur. Because low sulfur coal delineation can be estimated by a prominent and relatively easily observable geologic condition, the geographic coverage of data for sulfur can be more readily determined. Other quality parameters such as mercury do not have as strong a geologic indicator as sulfur and consequently rely heavily on more limited point measurements, therefore making large geographic extrapolations from these limited discreet element values more generalized and may not reflect local variability.

Indiana

For some parameters such as ash, sulfur, BTU – we have a lot of data, for some other parameters that may turn out to be critical (Cl, Hg, etc.), we do not have sufficient data to evaluate our coal resources.

Kansas

In general -- Yes, at least for the important coals that have the best stripping potential.

Kentucky

We have sufficient data to generally categorize coal beds into broad quality categories, but not to site specific mapping of quality.

15. Do you feel that you have sufficient data to evaluate your resources by pertinent quality parameters?

Louisiana

No

Mississippi

No.

Missouri

No, that data is not available.

Western

Alaska

No, beyond the available coal rank, generally there is insufficient and pertinent coal quality data available such as sulfur content, trace metals to fully evaluate the resources.

Arizona

No

Colorado

Yes but only for the selected active mineable areas we have studied. This only amounts to about 40 percent of the coal-bearing regions of the state. The CGS continues to digitize and include new coal regions in their GIS databases, but a statewide inventory must be compiled from studies at the individual coal field level. A statewide GIS project is beyond the scope of our studies currently.

Montana

A qualified yes. But the larger concern would be to compile existing data and evaluate state-wide reserves accurately.

New Mexico

For some areas, but not for the entire state.

North Dakota

No

Utah

As mentioned earlier, quality data is not uniform in geographic coverage or analytical extent (i.e. some lack ultimate or trace element analyses) for all coal beds or coalfields. Many major beds do have sufficient data for quality mapping, but there may be problems with protecting company confidential data in reporting this data.

Wyoming

Yes, coal quality parameters are designated under the Clean Air Act and initial coal quality assessments are made by the BLM. Once a specific acreage is nominated as a leasable tract under the LBA process, any coal quality information is no longer considered proprietary.

APPENDIX D: COAL-TO-LIQUIDS CASE STUDIES

INTRODUCTION

The Southern States Energy Board (SSEB) is crafting an initiative that will reduce the United States dependency on imported petroleum. As part of this initiative the SSEB proposes to use our nation's large domestic coal resource to produce ultra clean transportation fuels that are compatible with the existing liquid fuels distribution and end-use infrastructure.

In this section three coal types representative of U.S. bituminous, subbituminous, and lignites have been used as feedstocks to conceptual Fischer-Tropsch (FT) CTL facilities. In addition to using only coal as feedstocks to these plants, in two of the cases analyzed a mixture of woody biomass and coal was used.

Two general process configurations are used in this study. They are: (1) a simple recycle and (2) a once-through configuration. Each of these pertains to the way the Fischer-Tropsch (FT) synthesis reactor system and its associated product recovery and upgrading sections are arranged and operated. A general description of the simple recycle and once-through configurations follows.

THE SIMPLE RECYCLE CONFIGURATION

Figure 1 shows a generic block flow diagram of a simple recycle CTL configuration. In this configuration the feed coal is gasified with oxygen to produce a raw synthesis gas consisting of carbon monoxide and hydrogen. This raw synthesis gas is then cleaned to remove contaminants such as acid gases and the cleaned gas is then sent to FT synthesis. In the FT synthesis reactor the synthesis gas is reacted over catalysts to produce hydrocarbons. Complete conversion of the synthesis gas to hydrocarbons does not occur in one pass through the FT reactors. In the recycle configuration the effluent from the FT reactors is cooled to recover the portion constituting liquid fuels and the unconverted synthesis gas is recycled back to the FT reactors to increase the conversion to fuels. The carbon dioxide produced in synthesis is removed in the recycle loop. A portion of the FT effluent containing unconverted synthesis gas and light hydrocarbon gases is sent to the power generation section of the plant to provide the electric power needs of the facility.

THE ONCE-THROUGH CONFIGURATION

The once-through configuration is shown schematically in Figure 2. The once-through configuration differs from the simple recycle configuration in that the synthesis gas is passed once-through the FT reactors and the FT tail gas is sent directly to the power generation block after carbon dioxide removal. This results in a larger net electric power output than the recycle configuration.

CTL CASES ANALYZED

A total of 16 CTL cases were analyzed in this study. The description of these cases is given in Table 1. Although the plants process a particular coal it should be noted that these conceptual plants are generic and not site specific.

The objective of analyzing this suite of cases was to determine the impact of coal type, plant configuration, and plant size on the performance and economics.

FEEDSTOCK ANALYSES

The bituminous coal shown in Table 2 is meant to represent a typical U.S. bituminous coal. The coal is fed to the plant as-received (AR) and has a heating value of 11,800 Btu/lb (HHV).

The subbituminous coal shown in Table 3 contains 30 percent moisture on an AR basis. In order to feed this coal to a dry feed entrained gasifier it is assumed that this coal must be dried to 10 weight percent moisture. The as-fed (AF) coal is shown in Table 3 and has a heating value of 10,913 Btu/lb (HHV).

The representative lignite coal shown in Table 4 contains 36.5 percent moisture (AR) and 9.84 percent mineral matter and has a carbon content of only 37 weight percent. It is assumed that this lignite must be dried to 10 weight percent moisture to enable it to be fed to a high pressure dry feed entrained gasifier. The AF analysis is shown in Table 4 and it has a heating value of 8,978 Btu/lb (HHV).

A representative analysis of the woody biomass is shown in Table 5. On a dry basis this material contains about 48 weight percent carbon and almost 44 percent oxygen. It is assumed that this biomass is dried to 15 percent moisture before it is mixed with coal and fed to the gasifier. The AF biomass has a heating value of 7,104 Btu/lb (HHV).

CONCEPTUAL CTL PLANT PROCESS UNITS

Regardless of size, overall configuration, and feedstock, the CTL conceptual plants analyzed all have essentially the same process units in common. These were shown in the block flow diagrams in Figures 1 and 2. The following describes the overall function of these process operations.

Coal Preparation, Drying and Grinding

In the cases where subbituminous coal or lignite are used as feed materials, it is necessary to both reduce the size of the solids by crushing and grinding and to reduce their moisture content via a heated drying step. Typically a portion of the gas stream from the Fischer-Tropsch product recovery and upgrading step is used as a fuel source.

The system assumed for the drying and the grinding of the subbituminous coal and lignite in this study is a one-step system in which drying is accomplished while the coal

is ground to the desired product size. Coal is fed through mill surge bins to a roller mill where it is ground in the presence of hot gases that are being swept through the mill. The externally heated gas stream provides the drying energy requirements and carries the evaporated water from the system. The sized product coal is swept through an internal classifier for collection in baghouses. Nitrogen from the air separation unit (ASU) is used to blanket the coal and avoid oxidation that could cause pyrophoric behavior. The mill gases are recycled to maximize operational safety by keeping the overall oxygen content very low. The heat required for the drying operation is provided by diverting a small portion of clean fuel gas from FT product recovery and upgrading and burning it in an air heater.

The dried and ground coal still blanketed under nitrogen is delivered to the gasifier feeding system using a pneumatic conveying system.

For the bituminous coal cases the coal is crushed and ground to a pulverized size distribution, no drying is necessary.

Coal Slurry

In Cases 1 through 5 and 15 and 16, bituminous coal is ground and combined with water to create a coal-slurry. The coal-slurry is pumped at high pressure into a single-stage, slurry-feed gasifier. The solids content of the coal-slurry is typically 65 percent, by weight.

The Air Separation Unit

The oxygen for coal gasification is provided by an air separation unit (ASU). This design uses a conventional cryogenic ASU for production of 95 percent purity oxygen for coal gasification and for nitrogen for inert gas in coal drying and grinding.

The Gasification Systems

Two types of gasifiers were used in this study: a single-stage, slurry feed gasifier, and a single stage, dry feed gasifier.

In the Cases using bituminous coal, a single stage, slurry feed gasifier with quench was used. The bituminous coal is wet-milled to a size of about 100 microns before being combined with water to form a slurry. The slurry is fed to the gasifier with oxygen from an ASU. Gasification takes place at slagging temperatures, typically about 2,600 F and 450 psia. In the quench system, the hot syngas leaves the bottom of the gasifier along with liquid ash and enters a water quench chamber. The quench removes hydrogen chloride and particulate matter before further processing of the syngas.

In the Cases using subbituminous coal or lignite, a single stage, dry feed gasifier with water quench was used. This is an oxygen-blown, entrained gasifier with a heat transfer or 'cooling wall'. The heat transfer wall is used to cool the gasifier inside surface by removing heat for use in making steam. Subbituminous coal or lignite feed is ground and dried to 10 weight percent moisture before being sent to the pressurized lock

hoppers. The dried coal is fed to the gasifier using compressed nitrogen as the carrier gas. The reactants which are fed at the top of the gasifier are converted in the flame section. The oxygen to coal ratio is adjusted to keep the gasification temperature at about 2,600 F. The operating pressure is approximately 450 psia. Melted coal mineral matter flows vertically downward in parallel with the synthesis gas and leaves the gasifier through the bottom discharge section. The carbon conversion in this gasifier is typically very high about 99 percent. A direct contact water quench spray system is used at the gasifier exit to remove hydrogen chloride and particulate matter prior to further processing of the syngas.

Gas Cooling, Raw Water Gas Shift, Carbonyl Sulfide Hydrolysis, and Mercury Removal

The treatment scheme for the syngas produced by either type of gasifier is essentially the same. The synthesis gas stream leaving the gasifier quench section is split, and a portion of the stream is sent to a raw water gas shift reactor to adjust the hydrogen to carbon monoxide molar ratio to that required for the FT reactors. The other portion of the synthesis gas is sent to a carbonyl sulfide hydrolysis unit where the COS is hydrolyzed to hydrogen sulfide. The two streams, having a molar hydrogen to carbon monoxide ratio of about 1.0, are then combined and both streams are then cooled in gas coolers before being sent to activated carbon filtration for removal of mercury. This cooled gas is then sent to a two-stage Acid Gas Removal (AGR) unit for removal of hydrogen sulfide and carbon dioxide.

Acid Gas Removal

The raw synthesis gas at about 400 psi from mercury removal is sent to an AGR unit. The AGR unit selected is used for the selective removal of hydrogen sulfide and for bulk removal of carbon dioxide. The acid gas produced by this selective absorption is suitable for feeding to a Claus-type unit for acid gas treatment (AGT) and recovery of elemental sulfur.

Hydrogen Recovery

A portion of the clean synthesis gas leaving the AGR unit is sent to the hydrogen recovery unit where sufficient hydrogen is separated and purified for use in the FT upgrading section of the plant. This hydrogen is required for hydrotreating and hydrocracking. The hydrogen separation system chosen for this study is a combination of membranes and Pressure Swing Adsorption (PSA). The membrane system is used to avoid a pressure drop in the main synthesis gas stream. The final purification of the hydrogen is achieved by sending the permeate stream from the membrane unit to a PSA unit. Here the hydrogen is produced at 99.99 percent purity. The hydrogen leaves the PSA at essentially feed pressure while the PSA purge gases leave at essentially atmospheric pressure.

Sulfur Polishing

Depending on operating conditions, the synthesis gas exiting the AGR unit still contains about 1-2 ppmv H₂S. This quantity of H₂S is still too great to feed to the sulfur sensitive iron-based catalysts in the Fischer-Tropsch synthesis process. To remove this residual H₂S, zinc oxide polishing reactors are used. The zinc oxide reacts with the hydrogen sulfide to form solid zinc sulfide. The product gas leaving the polishing reactor contains less than 0.03 ppmv H₂S.

Fischer-Tropsch Synthesis

The clean synthesis gas containing less than .03 ppmv H₂S from the sulfur polishing reactor is sent to the FT section of the plant. At the required product production rates used in this study, multiple trains of slurry phase reactors are needed to process the clean synthesis gas. The synthesis gas is heated to about 400°F and fed to the bottom of the FT reactors. The gas bubbles up through the reactors that are filled with liquid hydrocarbons in which are suspended fine iron-based catalyst particles. Reaction heat is removed via heat exchangers suspended in the reactors. The liquid medium enables rapid heat transfer to the heat exchangers which allows high synthesis gas conversions in a single pass through the reactor. Synthesis gas conversions of about 80 percent per pass can be obtained.

Volatile overhead product swept from the reactors is separated in hot and cold separators to recover liquid hydrocarbons and the FT tail gas can either be sent to the power generation block or recycled to the FT reactors. In the simple recycle Cases, a portion of the tail gas is treated to remove CO₂ then sent back to the FT reactor train. Heavy product that is non-volatile under reaction conditions is removed from the reactor and separated from the catalyst. The raw FT products consisting of crude naphtha, crude middle distillate, and crude wax are sent directly to product upgrading. Fresh FT catalyst is activated in a separate catalyst activation reactor and then added on-line to the FT reactors to replace spent catalyst and to maintain overall activity. The catalyst replacement rate assumed in this study is 0.5 pounds per barrel of FT product.

FT Product Upgrading

The raw FT products need to be upgraded to produce naphtha and high quality diesel fuel. The raw naphtha and middle distillate is sent to a hydrotreating unit to saturate the olefins that are produced in the FT process. The wax material is sent to a hydrocracker where the wax is converted into hydrocarbon gases, naphtha and diesel fuel.

Carbon Dioxide Removal in Recycle Loop

The FT tail gas containing light hydrocarbon gases, unconverted hydrogen and carbon monoxide, some nitrogen, and carbon dioxide is split into two streams. One stream is recycled back to the FT unit to increase liquids yield and the other stream is sent to the power generation block. The recycled tail gas is processed in an amine unit to remove

the carbon dioxide that is inert and takes up space in the slurry FT reactors. This is a standard MDEA unit with a single carbon dioxide absorber and solvent regenerator.

Power Generation Block

The FT tail gas that is not recycled back to the FT reactors is sent to an advanced high temperature air cooled gas turbine where electric power is generated. The hot effluent gas from the gas turbine is sent to the heat recovery steam generator (HRSG).

High temperature flue gas exiting the gas turbine is sent to the HRSG to recover the large quantity of thermal energy as steam for the steam turbines. The HRSG is a multi-chamber, multi-pressure design that is matched to the characteristics of the gas turbine exhaust. The HRSG chamber pressures are typically 1,800 psia and 450 psia for the high pressure and intermediate pressure steam turbine sections, respectively. In addition to generating and superheating steam, the HRSG reheats steam released from the high pressure steam turbine and provides condensate and feedwater heating and pre-heating.

The steam turbine consists of a high pressure section (~1,800 psig, 1,050 F), an intermediate pressure section (~ 400 psig, 1,050 F), and a low pressure section. All three sections are connected mechanically to an electric power generator by a common shaft.

Balance of Plant (BOP) Units

Product storage:

Storage tanks are on site for storing naphtha and diesel fuels.

Water systems:

Systems are provided for cooling towers, to prepare boiler feed water (BFW), waste water treating, storm water handling, and fire water systems.

Electrical transformers and plant power distribution facilities are provided.

Instrumentation and Controls:

Unit operations instrumentation and control systems are provided.

TECHNICAL DESCRIPTIONS OF CASES ANALYZED

CASE 1: 10,000 BPD Bituminous Coal with Recycle

Figure 3 shows a block flow diagram for Case 1. This system produces 10,000 barrels per day on an equivalent diesel basis of naphtha and diesel. It uses bituminous coal as feed material to two trains of single stage, slurry feed gasifiers and has a simple recycle stream to the four (4) FT synthesis reactor trains (each FT reactor produces 2,500 BPD of product).

The as-fed coal input to the plant is 5,386 TPD. The products from this plant configuration are 3,507 BPD of FT naphtha, 7,495 BPD of FT diesel, and 190 MW of gross power. The total plant parasitic power is estimated to be 163 MW therefore the

net power available for sale is only 27 MW. The overall thermal efficiency of the plant on an HHV basis is calculated to be 47 percent.

CASE 2: 10,000 BPD Bituminous Coal Once Through

Figure 4 shows a block flow diagram for Case 2. This system produces 10,000 barrels per day on an equivalent diesel basis of naphtha and diesel. It uses bituminous coal as feed material to three trains of single stage, slurry feed gasifiers and, in contrast to Case 1, has a once-through configuration to the four FT synthesis reactor trains. The system is sized to provide sufficient FT tail gas to power a single advanced gas turbine. To improve carbon capture a carbon dioxide removal system is used before the gas turbine.

The as-fed coal input to the plant is 7,414 TPD. The products from this plant configuration are 3,507 BPD of FT naphtha, 7,495 BPD of FT diesel, and 457 MW of gross power. The total plant parasitic power is estimated to be 215 MW therefore the net power available for sale is 241 MW. The overall thermal efficiency of the plant on an HHV basis is calculated to be 44 percent.

CASE 3: 30,000 BPD, Bituminous Coal with Recycle

Figure 5 shows a block flow diagram for Case 3. This system produces 30,000 barrels per day on an equivalent diesel basis of naphtha and diesel. It uses bituminous coal as feed material to six (6) trains of single stage, slurry feed gasifiers and has a simple recycle stream to the six (6) FT synthesis reactor trains. In this case each FT reactor can produce 5,000 BPD of products. The FT tail gas is sufficient to power an advanced gas turbine.

The as-fed coal input to the plant is 17,987 TPD. The products from this plant configuration are 11,398 BPD of FT naphtha, 24,359 BPD of FT diesel, and 725 MW of gross power. The total plant parasitic power is estimated to be 521 MW therefore the net power available for sale is 204 MW. The overall thermal efficiency of the plant on an HHV basis is calculated to be 48 percent.

CASE 4: 30,000 BPD, Bituminous Coal Once Through

Figure 6 shows a block flow diagram for Case 4. This system produces 30,000 barrels per day on an equivalent diesel basis of naphtha and diesel. It uses bituminous coal as feed material to seven (7) trains of single stage, slurry feed gasifiers and has a once-through configuration to the six FT synthesis reactor trains. The system is sized to produce sufficient FT tail gas to power two advanced gas turbines.

The as-fed bituminous coal input to the plant is 19,517 TPD. The products from this plant configuration are 10,521 BPD of FT naphtha, 22,485 BPD of FT diesel, and 1,045 MW of gross power. The total plant parasitic power is estimated to be 508 MW therefore the net power available for sale is 537 MW. The overall thermal efficiency of the plant on an HHV basis is calculated to be 47 percent.

CASE 5: 60,000 BPD, Bituminous Coal with Recycle

Figure 7 shows a block flow diagram for Case 5. This system produces 60,000 barrels per day on an equivalent diesel basis of naphtha and diesel. It uses bituminous coal as feed material to 12 trains of single stage, slurry feed gasifiers and has a simple recycle stream to the 12 FT synthesis reactor trains.

The as-fed coal input to the plant is 33,640 TPD. The products from this plant configuration are 21,042 BPD of FT naphtha, 44,970 BPD of FT diesel, and 1,360 MW of gross power. The FT tail gas feeds two advanced gas turbines. The total plant parasitic power is estimated to be 974 MW therefore the net power available for sale is 386 MW. The overall thermal efficiency of the plant on an HHV basis is calculated to be 48 percent.

CASE 6: 10,000 BPD, Subbituminous Coal with Recycle

Figure 8 shows a block flow diagram for Case 6. This system produces 10,000 barrels per day on an equivalent diesel basis of naphtha and diesel. It uses subbituminous coal as feed material to two trains of single stage, dry-feed gasifiers with water quench and has a simple recycle stream to the 4 FT synthesis reactor trains.

The as-fed coal input to the plant is 5,348 TPD. This has been dried and ground to the required water content and size before conveyance to the gasifiers. The products from this plant configuration are 3,507 BPD of FT naphtha, 7,495 BPD of FT diesel, and 162 MW of gross power. The total plant parasitic power is estimated to be 143 MW therefore the net power available for sale is only 19 MW. The overall thermal efficiency of the plant on an HHV basis is calculated to be 51 percent.

CASE 7: 10,000 BPD, Subbituminous Coal Once Through

Figure 9 shows a block flow diagram for Case 7. This system produces 10,000 barrels per day on an equivalent diesel basis of naphtha and diesel. It uses subbituminous coal as feed material to three trains of single stage, dry-feed gasifiers and has a once-through configuration to the 4 FT synthesis reactor trains.

The as-fed coal input to the plant is 7,364 TPD. This has been dried and ground to the required moisture content and size before conveyance to the dry feed entrained gasifiers. The products from this plant configuration are 3,507 BPD of FT naphtha, 7,495 BPD of FT diesel, and 353 MW of gross power. The total plant parasitic power is estimated to be 191 MW therefore the net power available for sale is 162 MW. The overall thermal efficiency of the plant on an HHV basis is calculated to be 44 percent.

CASE 8: 30,000 BPD, Subbituminous Coal with Recycle

Figure 10 shows a block flow diagram for Case 8. This system produces 30,000 barrels per day on an equivalent diesel basis of naphtha and diesel. It uses subbituminous coal

as feed material to 6 trains of single stage, dry-feed gasifiers and has a simple recycle stream to the 6 FT synthesis reactor trains.

The as-fed coal input to the plant is 17,905 TPD. This has been dried and ground to the required moisture content and size before conveyance to the gasifiers. The products from this plant configuration are 11,222 BPD of FT naphtha, 23,984 BPD of FT diesel, and 597 MW of gross power. The FT tail gas is sufficient to power one advanced gas turbine. The total plant parasitic power is estimated to be 451 MW therefore the net power available for sale is 146 MW. The overall thermal efficiency of the plant on an HHV basis is calculated to be 50 percent.

CASE 9: 60,000 BPD, Subbituminous Coal with Recycle

Figure 11 shows a block flow diagram for Case 9. This system produces 60,000 barrels per day on an equivalent diesel basis of naphtha and diesel. It uses subbituminous coal as feed material to 11 trains of single stage, dry-feed gasifiers and has a simple recycle stream to the 12 FT synthesis reactor trains.

The as-fed coal input to the plant is 31,225 TPD. This has been dried and ground to the required water content and size before conveyance to the gasifiers. The products from this plant configuration are 21,042 BPD of FT naphtha, 44,970 BPD of FT diesel, and 830 MW of gross power. The total plant parasitic power is estimated to be 785 MW therefore the net power available for sale is only 45 MW. The overall thermal efficiency of the plant on an HHV basis is calculated to be 51 percent.

CASE 10: 10,000 BPD, Lignite with Recycle

Figure 12 shows a block flow diagram for Case 10. This system produces 10,000 barrels per day on an equivalent diesel basis of naphtha and diesel. It uses lignite as feed material to two trains of single stage, dry-feed gasifiers and has a simple recycle stream to the 4 FT synthesis reactor trains.

The as-fed lignite input to the plant is 7,378 TPD. This has been dried and ground to the required moisture level and size before conveyance to the gasifiers. The products from this plant configuration are 3,507 BPD of FT naphtha, 7,495 BPD of FT diesel, and 178 MW of gross power. The total plant parasitic power is estimated to be 172 MW therefore the net power available for sale is only 6 MW. The overall thermal efficiency of the plant on an HHV basis is calculated to be 44 percent.

CASE 11: 10,000 BPD, Lignite Once Through

Figure 13 shows a block flow diagram for Case 11. This system produces 10,000 barrels per day on an equivalent diesel basis of naphtha and diesel. It uses lignite as feed material to three trains of single stage, dry-feed gasifiers and has a once-through configuration to the 4 FT synthesis reactor trains.

The as-fed lignite input to the plant is 9,697 TPD. This has been dried and ground to the required moisture and size before conveyance to the gasifiers. The products from this plant configuration are 3,507 BPD of FT naphtha, 7,495 BPD of FT diesel, and 384 MW of gross power. The FT tail gas is sufficient to power one advanced gas turbine. The total plant parasitic power is estimated to be 221 MW therefore the net power available for sale is 163 MW. The overall thermal efficiency of the plant on an HHV basis is calculated to be 41 percent.

CASE 12: 30,000 BPD, Lignite with Recycle

Figure 14 shows a block flow diagram for Case 12. This system produces 30,000 barrels per day on an equivalent diesel basis of naphtha and diesel. It uses lignite as feed material to 8 trains of single stage, dry-feed gasifiers and has a simple recycle stream to the 6 FT synthesis reactor trains.

The as-fed lignite input to the plant is 23,775 TPD. This has been dried and ground to the required moisture content and size before conveying to the gasifiers. The products from this plant configuration are 11,362 BPD of FT naphtha, 24,284 BPD of FT diesel, and 617 MW of gross power. The FT tail gas is sufficient to power an advanced gas turbine. The total plant parasitic power is estimated to be 526 MW therefore the net power available for sale 91 MW. The overall thermal efficiency of the plant on an HHV basis is calculated to be 46 percent.

CASE 13: 30,000 BPD, Lignite Once Through

Figure 15 shows a block flow diagram for Case 13. This system produces 30,000 barrels per day on an equivalent diesel basis of naphtha and diesel and a net power output of 430 MW. It uses lignite as feed material to 9 trains of single stage, dry-feed gasifiers and has a once-through configuration to the 6 FT synthesis reactor trains.

The as-fed lignite input to the plant is 26,653 TPD. This has been dried and ground to the required size and moisture before conveying to the gasifiers. The products from this plant configuration are 10,521 BPD of FT naphtha, 22,485 BPD of FT diesel, and 960 MW of gross power. Two trains of advanced gas turbines are used in the power block. The total plant parasitic power is estimated to be 528 MW therefore the net power available for sale is 432 MW. The overall thermal efficiency of the plant on an HHV basis is calculated to be 44 percent.

CASE 14: 60,000 BPD, Lignite with Recycle

Figure 16 shows a block flow diagram for Case 14. This system produces 60,000 barrels per day on an equivalent diesel basis of naphtha and diesel. It uses lignite as feed material to 14 trains of single stage, dry-feed gasifier and has a simple recycle stream to the 12 FT synthesis reactor trains.

The as-fed lignite input to the plant is 41,320 TPD. This has been dried and ground to the required size before conveying to the gasifiers. The products from this plant

configuration are 21,042 BPD of FT naphtha, 44,970 BPD of FT diesel, and 922 MW of gross power. The total plant parasitic power is estimated to be 913 MW therefore the net power available for sale is only 9 MW. The overall thermal efficiency of the plant on an HHV basis is calculated to be 47 percent.

CASE 15: 10,000 BPD Bituminous Coal plus 10% Woody Biomass

Figure 17 shows a block flow diagram for Case 15. This system produces 10,000 barrels per day on an equivalent diesel basis of naphtha and diesel. It uses bituminous coal plus 10 percent woody biomass as feed material to 2 trains of single stage, slurry feed gasifiers and has a simple recycle stream to the 4 FT synthesis reactor trains.

The as-fed coal/biomass input to the plant is 5,660 TPD. Of this 5,100 TPD is bituminous coal and 560 TPD is woody biomass. It is assumed that the coal and biomass can be cofed to the gasifiers although, as far as we know, this has not been demonstrated on a commercial scale. Woody biomass is difficult to feed to high pressure systems. NUON in the Netherlands has fed some demolition wood to their Shell gasifier in Buggenum but the wood had to be dried and finely ground before feeding. Some testing has been done with biomass cogasification at the GE gasifier at Polk but the concern is that the slurry rheology will be affected by the swelling of the fibrous wood.

Assuming that cogasification is possible the products from this plant configuration are 3,507 BPD of FT naphtha, 7,495 BPD of FT diesel, and 194 MW of gross power. The total plant parasitic power is estimated to be 166 MW therefore the net power available for sale is only 28 MW. The overall thermal efficiency of the plant on an HHV basis is calculated to be 47 percent.

CASE 16: 10,000 BPD Bituminous Coal plus 20% Woody Biomass

Figure 18 shows a block flow diagram for Case 16. This system produces 10,000 barrels per day on an equivalent diesel basis of naphtha and diesel. It uses bituminous coal plus 20 percent woody biomass as feed material to 2 trains of single stage, slurry feed gasifiers and has a simple recycle stream to the 4 FT synthesis reactor trains. As in Case 15 it is assumed that this mixture can be cogasified.

The as-fed coal/biomass input to the plant is 5,975 TPD. The products from this plant configuration are 3,507 BPD of FT naphtha, 7,495 BPD of FT diesel, and 199 MW of gross power. The total plant parasitic power is estimated to be 170 MW therefore the net power available for sale is 29 MW. The overall thermal efficiency of the plant on an HHV basis is calculated to be 46 percent.

ECONOMICS

Table 6 summarizes the capital equipment costs for the 5 bituminous coal cases analyzed in this study. For convenience the capital costs are disaggregated into major plant sections.

Solids handling refers to all equipment associated with the storage, reclaiming, conveying, crushing and sampling of coal. The gasification section includes the feed preparation, the gasifiers, quench system, and slag removal. The air separation unit (ASU) is a standard cryogenic system for separation of oxygen and nitrogen. The syngas cleanup system contains several components that remove hydrogen sulfide, carbonyl sulfide, cyanide, ammonia, particulates, mercury, and carbon dioxide. It also includes acid gas treatment and sulfur recovery. The carbon dioxide capture section includes shift, carbon dioxide removal, and carbon dioxide compression to 2000 psi. The FT section includes the synthesis reactors, catalyst activation, FT product upgrading, and hydrogen and hydrocarbon recovery. The power block includes gas turbines, heat recovery steam generation, steam turbine, nitrogen compression, cooling water systems, feedwater and other plant water treatment systems, air cooling in the case of subbituminous and lignites feeds, and the plant electrical and distribution system. The balance of plant includes product tankage, instrumentation and controls, site improvements, and buildings and structures.

Referring to Table 6 the total installed costs of the bituminous coal plants vary from \$784 million (MM) for the small 10,000 BPD facility (Case 1) to \$3.91 billion for the large 60,000 BPD facility (Case 5).

Table 7 summarizes the additional capital requirements for these plants. This includes home office costs (mostly front end engineering and design FEED), project contingency, license, financing and legal fees, and non-depreciable capital. In this study no process contingencies were included. The total capital requirements varied with plant size from \$977 MM (Case 1) to \$4.67 billion for the 60,000 BPD plant (Case 5).

Table 8 summarizes the annual operating costs for these bituminous coal CTL plants. Fixed operating costs include royalties, labor and overhead, administrative labor, local taxes and insurance, and maintenance materials. Variable operating costs include coal feed cost considered to be \$36/ton, catalyst, water and chemicals, and other which is primarily solids disposal costs. The by product credit refers to sales of recovered sulfur. Net annual operating costs vary from \$123 MM for Case 1 to \$668 MM for Case 5. There are no purchases of electricity because all power required is generated on site. The small quantities of natural gas required for start up are not included.

Table 9 summarizes the overall inputs of coal and outputs of fuels and electric power from the bituminous plants. Also included on this table are the estimated plant parasitic power, gross power, sulfur recovered, and carbon dioxide captured. The overall thermal inputs and outputs from the plants allow the overall efficiency to be determined.

The bituminous coal is fed to the plant as received in that no drying is necessary. Coal feed varies from about 5,400 TPD (Case 1) to 33,600 TPD for the large 60,000 BPD plant. Total liquid fuels output varies from 11,000 BPD to over 66,000 BPD for Case 5. Equivalent diesel is calculated by assuming that the naphtha product has a value of 71 percent compared to the diesel fraction. The diesel is the more valuable product since it has zero sulfur and a cetane number of about 75, whereas the naphtha, being

predominantly paraffinic, has a low octane number. This naphtha could be used as a zero sulfur blending stock with petroleum naphtha for gasoline or it is an excellent cracker feed for ethylene production.

Since all electric power is generated onsite the parasitic power requirement for these plants can be quite high. For Case 5 it is close to 1000 MW. Much of this power requirement is for the cryogenic air separation units that produce the oxygen for the gasifiers. The overall efficiencies for these bituminous coal CTL plants vary with the ratio of net power to fuels products. The highest efficiencies at about 48 percent (HHV) are for Cases 3 and 5 (simple recycle). This is because it is more efficient to produce fuels than to generate electric power.

Table 10 summarizes the economics for these bituminous coal cases. The capital cost of these plants in terms of capital dollars per daily barrel (DB) of fuels produced varies from a high of \$88,700/DB for the small 10,000 BPD plant to \$70,700/DB for the large 60,000 BPD plant. This illustrates the importance of economies of scale for these CTL facilities. Referring to the results for Case 5 in Table 10, the diesel required selling price is estimated to be \$57.23/B. This is the combination of the capital component (\$28.84/B), the coal cost (\$20.18/B), the other O&M costs (\$13.70/B) minus the electric power credit (\$5.50/B). The required selling price on a crude oil equivalent (COE) basis is determined by dividing this number \$57.23/B by the factor 1.3. This gives the COE cost of \$44.02/B. The factor 1.3 represents the ratio of the value of low sulfur diesel to West Texas Intermediate (WTI) crude oil.

Tables 11, 12, 13, 14, and 15 summarize the economic results for the subbituminous coal cases. The same format is used as for the bituminous coals. In Table 14 there are two sets of coal inputs. One set shows the as received subbituminous coal containing 30 percent moisture and the other set shows the as-fed subbituminous coal dried to 10 percent moisture. The coal handling section of the capital cost table includes the drying cost. The as-received cost of the subbituminous coal is assumed to be \$11 per ton.

The overall plant efficiencies for the subbituminous cases in simple recycle configuration are around 51 percent (HHV). The once through case 7 is lower (44 percent) because of the higher ratio of net power sales to liquid fuels product. The required selling price on a COE basis varies between about \$46/B for the small plant to about \$35/B for the 60,000 BPD plant.

Tables 16, 17, 18, 19, and 20 summarize the economic results for the lignite coal cases. Again the same format is used. In Table 19 there are two sets of coal inputs. One set shows the as received lignite containing 36.5 percent moisture and the other set shows the as-fed lignite dried to 10 percent moisture. The coal handling section of the capital cost table includes the drying cost. The as-received cost of the lignite is assumed to be \$10 per ton.

The overall plant efficiencies for the lignite cases in simple recycle configuration are around 45 percent (HHV). The once through cases 11 and 13 are lower (41-43 percent)

because of the higher ratio of net power sales to liquid fuels product. The required selling price on a COE basis for the recycle cases varies between about \$56/B for the small plant to about \$41/B for the 60,000 BPD plant.

Tables 21, 22, 23, 24, and 25 summarize the economic results for the cogasification bituminous coal and woody biomass cases. Again the same format is used and Case 1 (bituminous coal only) is shown for comparison. In Table 24 there are two sets of inputs. One set shows the bituminous coal input and the other set shows the as-fed woody biomass containing 15 percent moisture. The coal handling section of the capital cost table includes the drying cost. The cost of dry woody biomass is assumed to be \$20 per ton at the CTL plant gate.

The overall plant efficiencies for the bituminous coal/woody biomass cases in simple recycle configuration are around 46 percent (HHV). The required selling price on a COE basis for these cases varies between about \$55 and \$56/B depending on the percentage of woody biomass fed.

The required selling prices (RSP) of the liquid fuel product from all of these plants were estimated using discounted cash flow (DCF) analyses based on the economic assumptions shown in Table 26.

SENSITIVITIES

Figure 19 shows sensitivities to the baseline 30,000 BPD bituminous CTL plant with simple recycle (Case 3) that would result in a reduction in the RSP of the equivalent diesel fuel product. The baseline Case 3 plant has an equivalent diesel fuel RSP of \$45.95 per barrel crude oil equivalent. This baseline plant has no captured carbon dioxide credit, a coal cost of \$36 per ton, an electric power value of \$35.6/MWH, a capacity factor of 90 percent, and a naphtha to diesel ratio of 0.32. Figure 19 shows the cumulative impact on the RSP of this base Case 3 plant if there was a \$12 per ton credit for the captured carbon dioxide, a reduction in the coal cost to \$30 per ton, an increase in power value to \$55/MWH, an increase in the capacity factor to 95 percent, and a decrease in the naphtha to diesel ratio to 0.2.

If all of these improvements were realized then the RSP would be reduced from \$45.95 per barrel crude oil equivalent to \$31.13 per barrel crude oil equivalent.

Conversely the RSP of the diesel product from the baseline Case 3 CTL plant would be increased if a cost was required to sequester the carbon dioxide, if the bituminous coal cost was higher, if the value of the electric power was lower, if the capacity of the plant was reduced, and if the naphtha to diesel ratio remained at 0.32. Figure 20 shows the cumulative impact on the RSP of diesel for the Case 3 CTL plant if it cost \$5 per ton to sequester the captured carbon dioxide, if the coal cost was \$50 per ton, if the power value was only \$25/MWH, if the capacity factor was only 85 percent, and the naphtha to diesel ratio remained at 0.32.

If all of these negative sensitivities were to occur then the RSP would be increased from \$45.95 per barrel crude oil equivalent to \$58.11 per barrel crude oil equivalent.

EMISSIONS

Table 27 summarizes a rough estimate of the expected emissions of nitrogen oxides and sulfur oxides from these CTL plants. A detailed emissions analysis was not performed in this study but the NO_x emissions were estimated based on the assumption that the gas turbine is the primary source of NO_x and that the process contains an SCR unit that reduces the effluent NO_x to 3 ppm on a 15 percent oxygen basis. There are some fired heaters in the CTL plants that will contribute to NO_x emissions but the extent of this additional contribution has not been determined at the level of analysis in this study. The SO_x emissions will be very low because of the extensive cleaning of the synthesis gas to less than 1 ppm sulfur.

The carbon dioxide emissions shown in Table 26 have been estimated from the overall carbon balance throughout the CTL plants. All of these plants are configured to capture carbon dioxide with the range of capture varying between 91 percent and 74 percent.

Although developing a detailed plant water usage balance was beyond the scope of this feasibility analysis, a rough estimate of water usage was attempted. For the bituminous coal cases using a slurry feed gasifier, a natural draft wet cooling tower was used to cool the water for the steam condenser. The total make-up water requirement for the cooling tower, deaerator blowdown, and slurry feed was estimated to be in the range of 8-10 barrels of water per barrel of liquid fuels product. For the subbituminous and lignite cases, where maximum air cooling is used, the approximate water usage can be reduced to about one barrel of water per barrel of product. To perform a detailed water balance throughout these plants is complicated and a more thorough analysis would be necessary to have more confidence in these water use estimates.

SUMMARY AND CONCLUSIONS

Table 28 summarizes some of the major results for the 16 cases analyzed in this study.

For the techno-economic assumptions and basis used in this study, the results support the following conclusions:

- This feasibility study has shown that low-sulfur diesel can be produced economically from domestic coal using existing technologies, compared to current prices of crude oil and petroleum refined liquid fuel products.
- For the economic assumptions and coal types used in this study, the most economically attractive configuration is the dry-feed gasification and recycle FT reactor configuration using subbituminous coal.

- Co-gasification of bituminous coal with woody biomass has a minor negative impact on the economics of the process. However it must be stressed that the co-gasification cases assume that the biomass and coal can be co-fed to the slurry gasifier. It is not clear if this could be accomplished commercially.
- Recycle configurations are more economical than once through configurations that generate large amounts of net electric power for all coal types and all plant sizes. This is because the baseline value of power is set at \$35.6/MWH. If this value of power is increased about \$50/MWH then the once through cases will generally be more economical than the recycle cases. Therefore for the economic assumptions used in this study, the plant should be configured for minimum export power.
- The scaling methodology used in this study reduces the cost per barrel of product with increasing plant size following a power law type curve. The data also suggests that the exponent for economies of scale approaches one at plant capacities of around 60,000 BPD. Although some additional economy of scale may be realized with plants larger than 60,000 BPD it is likely to be fairly small.
- Annualized capital costs and operating costs (including coal cost) contribute approximately equally to the required selling price of the product.
- The most important variables governing the required selling price of the diesel are the value of the CO₂ product, the price of coal, and the value of the exported electricity.
- For the sensitivities analyzed (coal price, CO₂ credit, capacity, power value, and naphtha to diesel ratio) these could impact the estimated required selling price by up to -32% / +26%.
- The recycle configurations can attain a CO₂ capture percentage of approximately 90%.
- The NO_x and SO_x emissions from the CTL plants are extremely low.
- This study is not a detailed engineering and economic analysis. It is a feasibility analysis using certain specified coal inputs to generic non site specific conceptual CTL plants. As such the accuracy of the capital costs is expected to be about +/- 30 percent. Even if the capital cost for the cases analyzed was 30 percent greater than estimated in this study in all but two cases (Cases 2 and 11) the RSP of the fuels would be competitive with petroleum at less than \$65 per barrel.
- Even if the cost of bituminous coal was \$70 per ton the RSP of the liquid fuels in Case 5 would be \$65 per barrel.

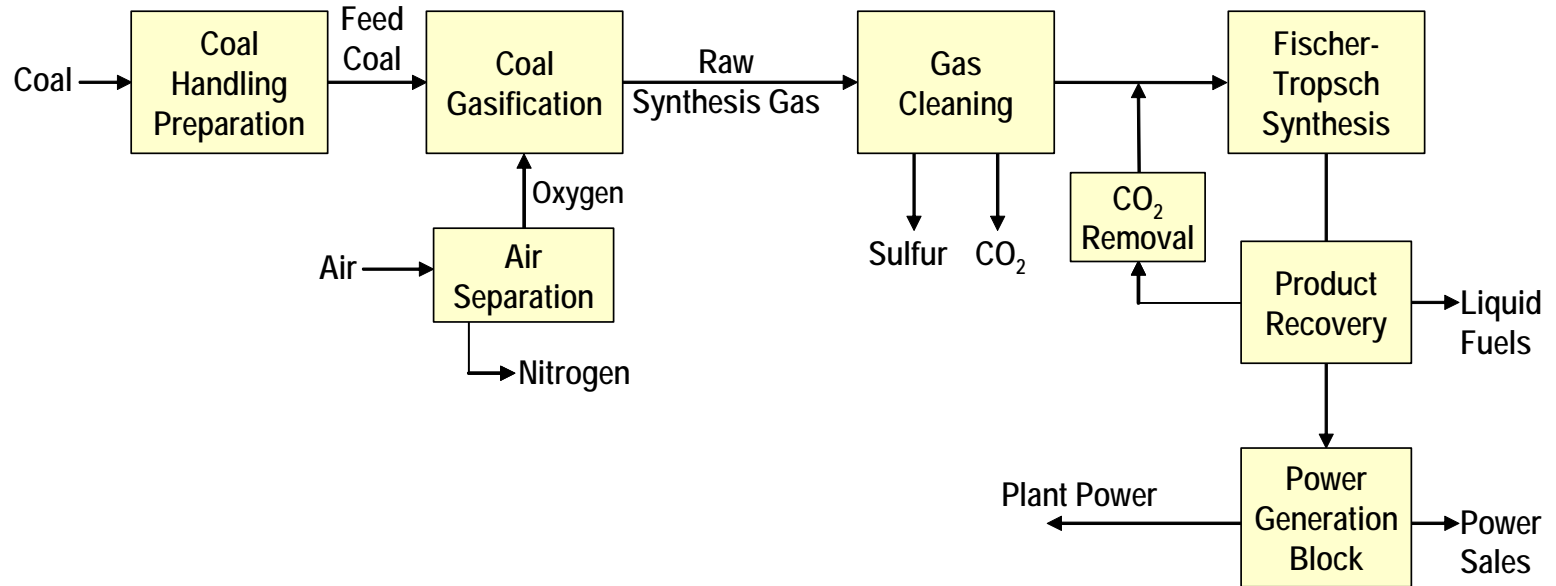

Figure 1. Generic Simple Recycle Coal to Liquid Configuration

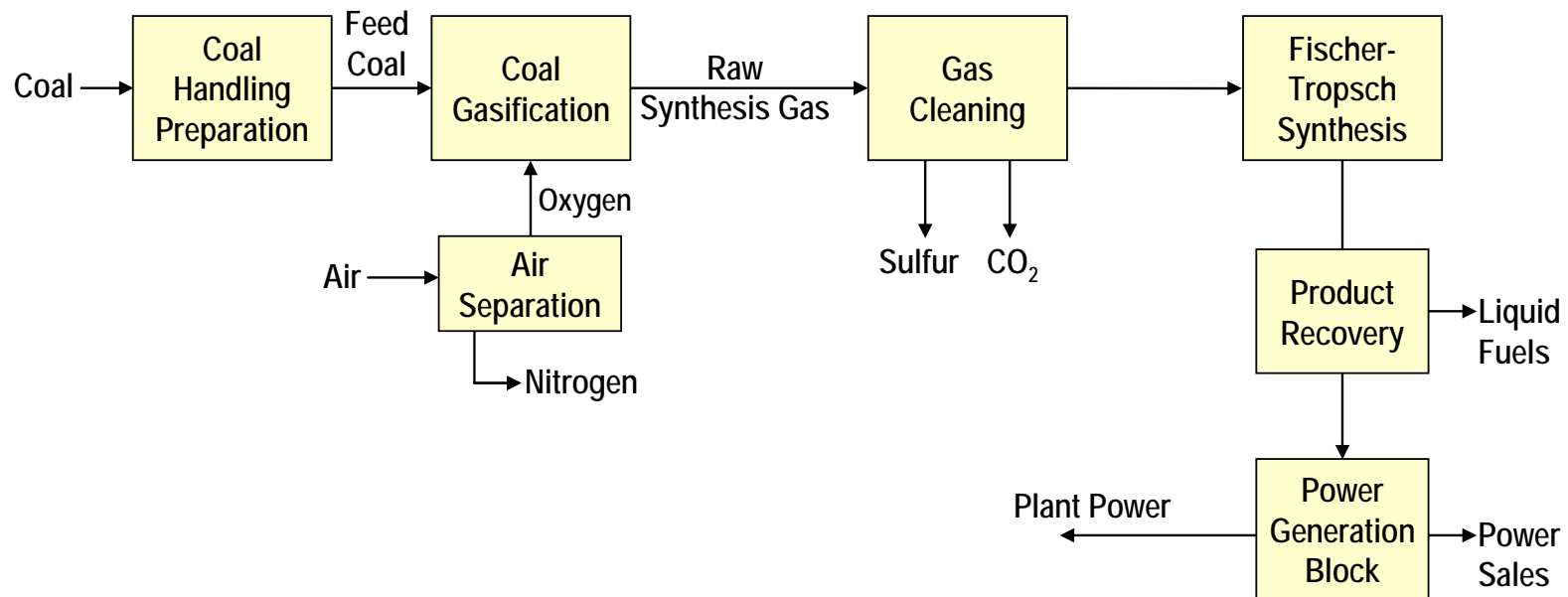

Figure 2. Generic Once-Through Coal to Liquid Configuration

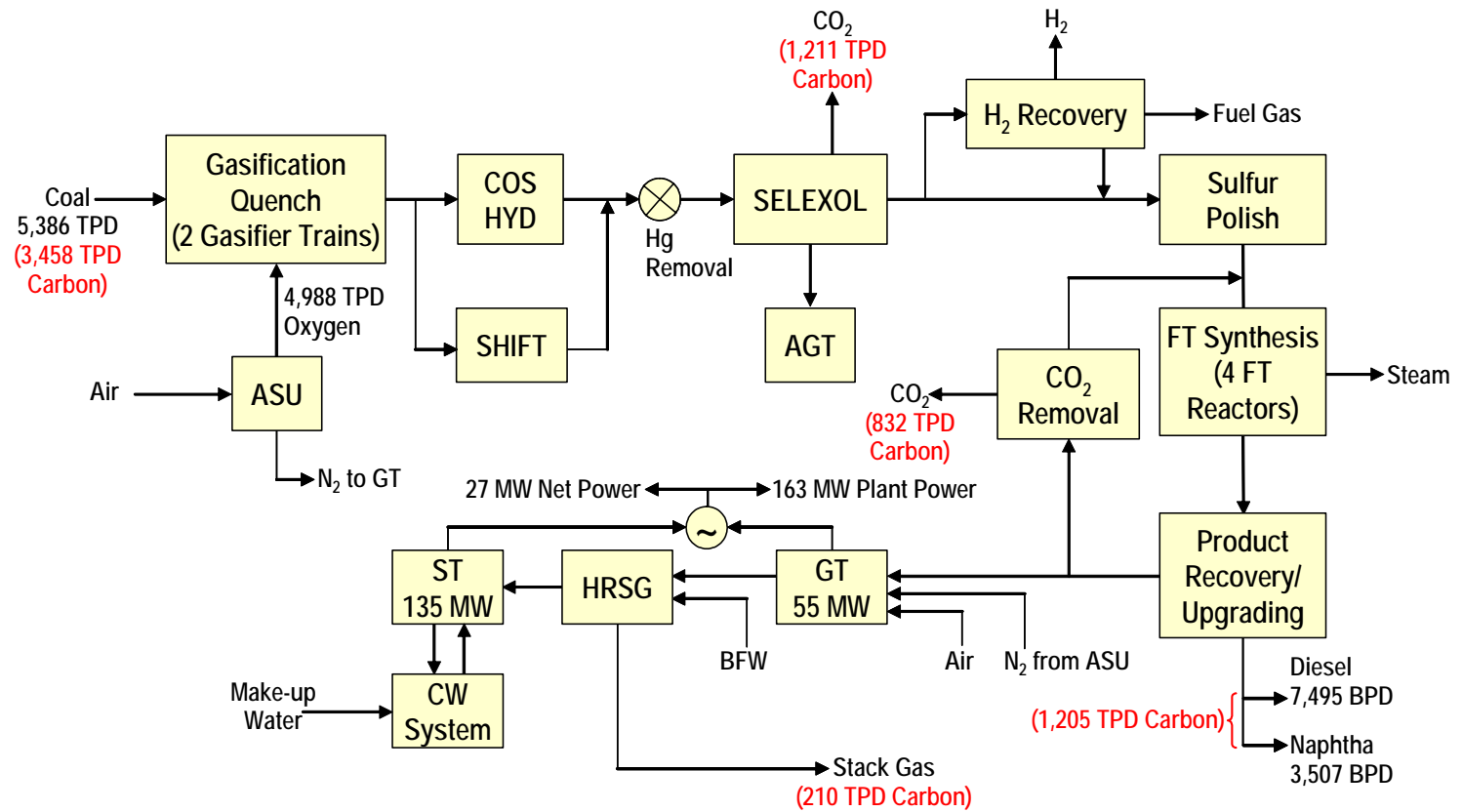

Figure 3. Case 1 – 10,000 BPD, Bituminous Coal, with Recycle

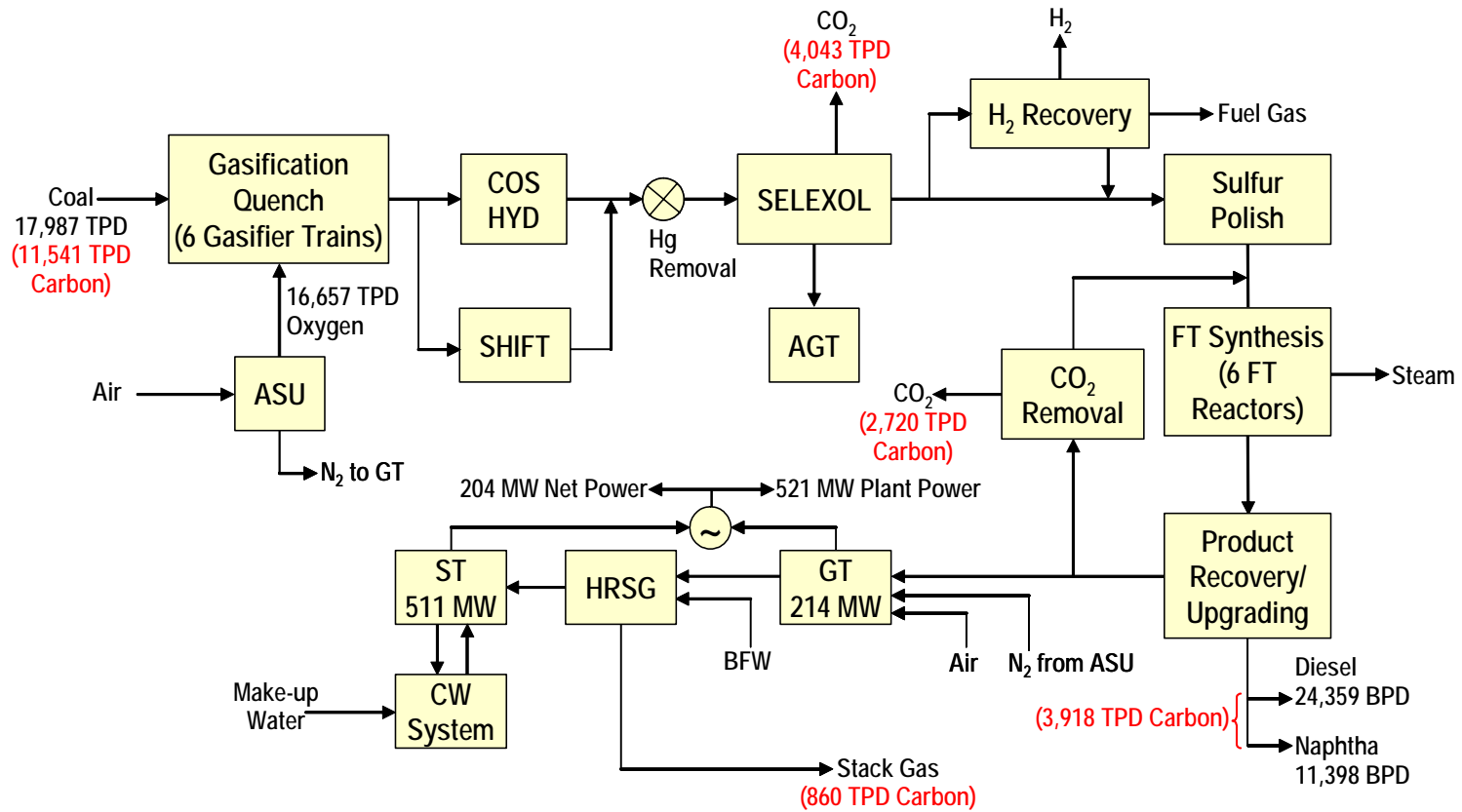

Figure 5. Case 3 – 30,000 BPD, Bituminous Coal, with Recycle

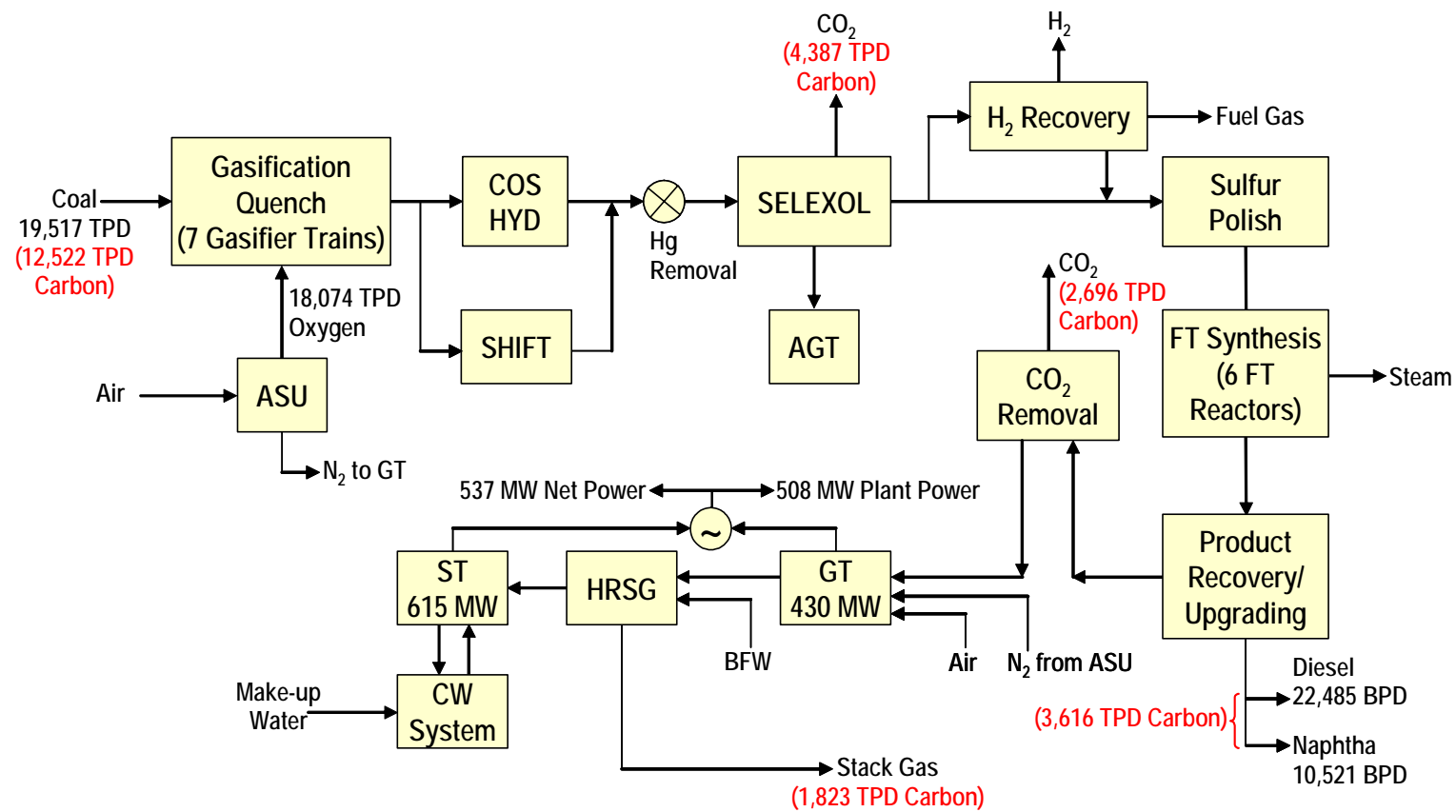

Figure 6. Case 4 – 30,000 BPD, Bituminous Coal, Once-Through

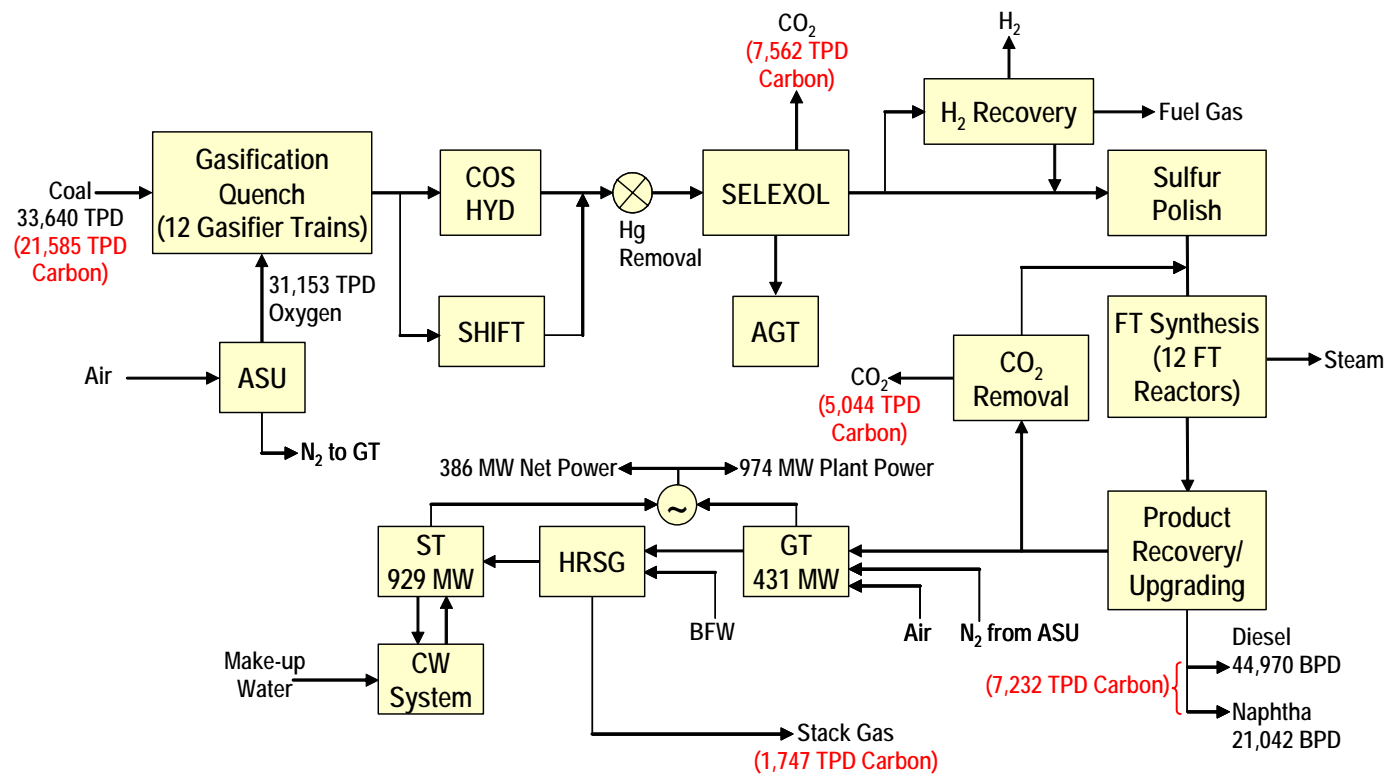

Figure 7. Case 5 – 60,000 BPD, Bituminous Coal, with Recycle

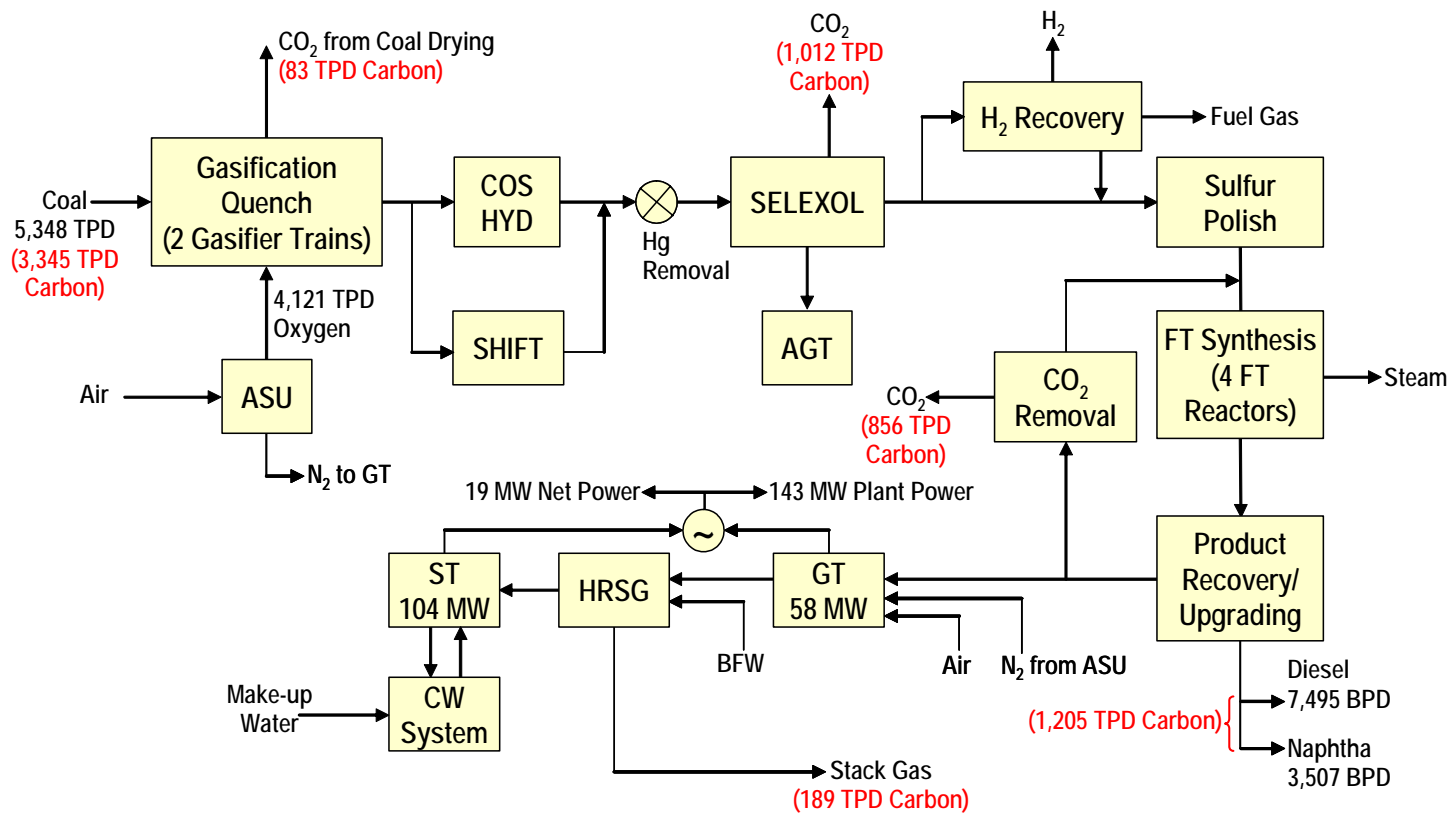

Figure 8. Case 6 – 10,000 BPD, Subbituminous Coal, with Recycle

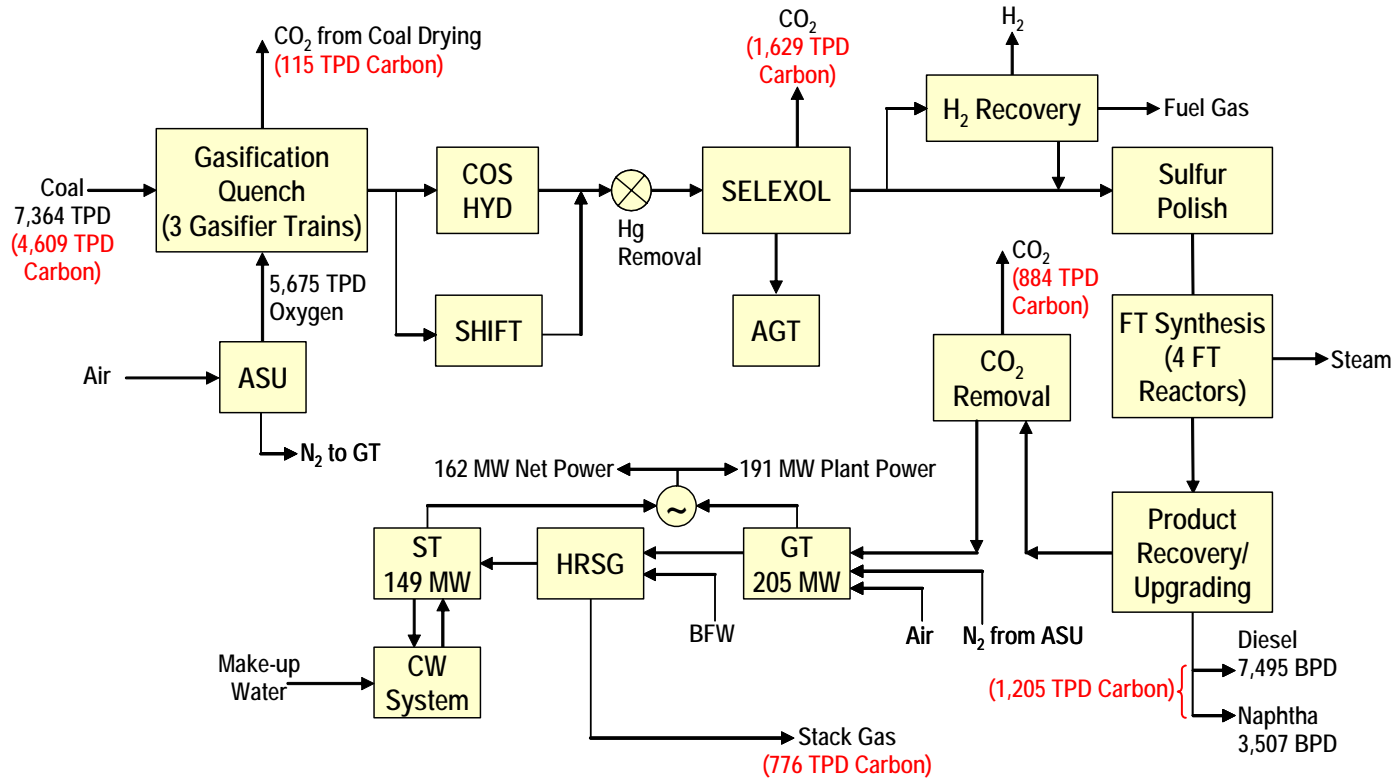

Figure 9. Case 7 – 10,000 BPD, Subbituminous Coal, Once-Through

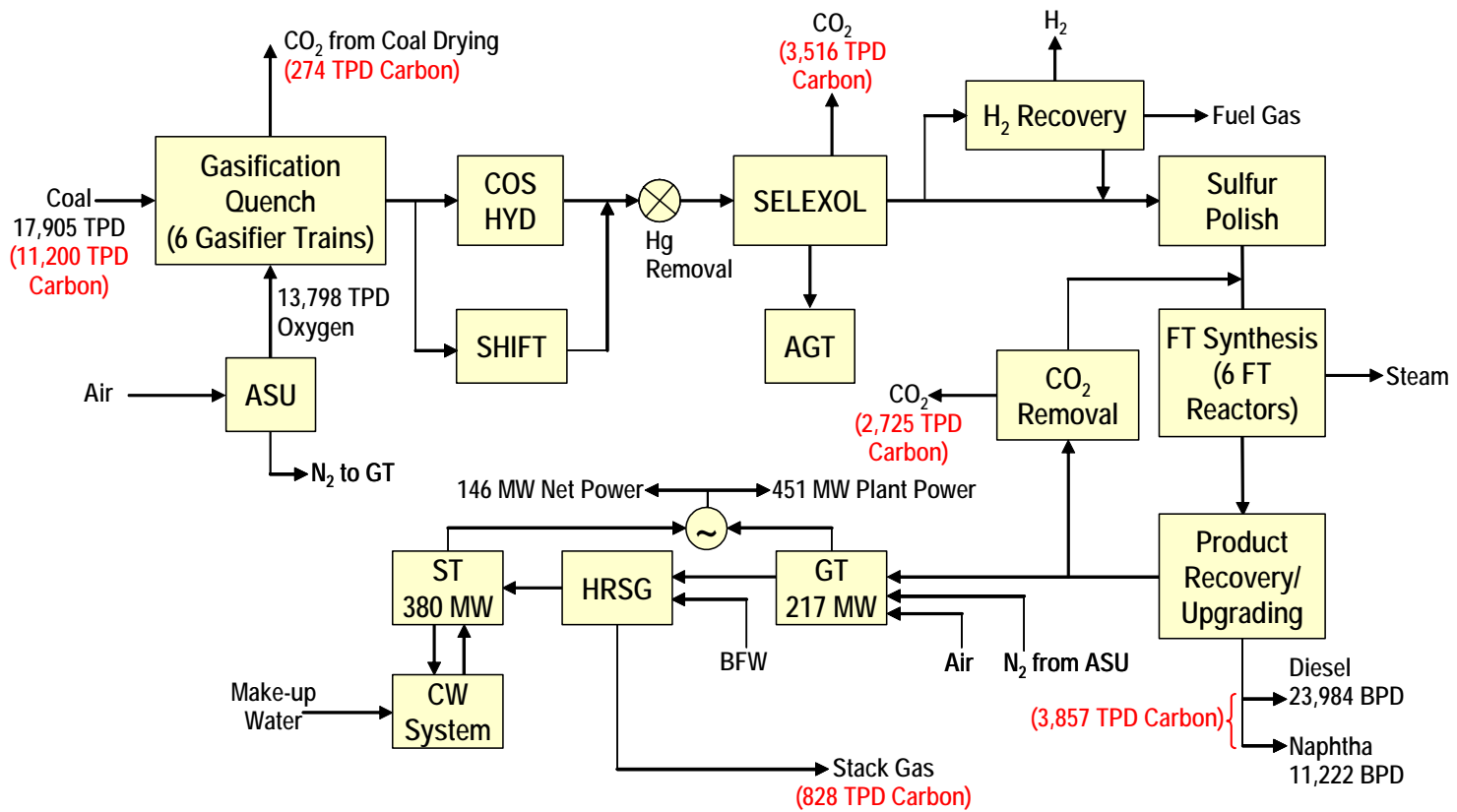

Figure 10. Case 8 – 30,000 BPD, Subbituminous Coal, with Recycle

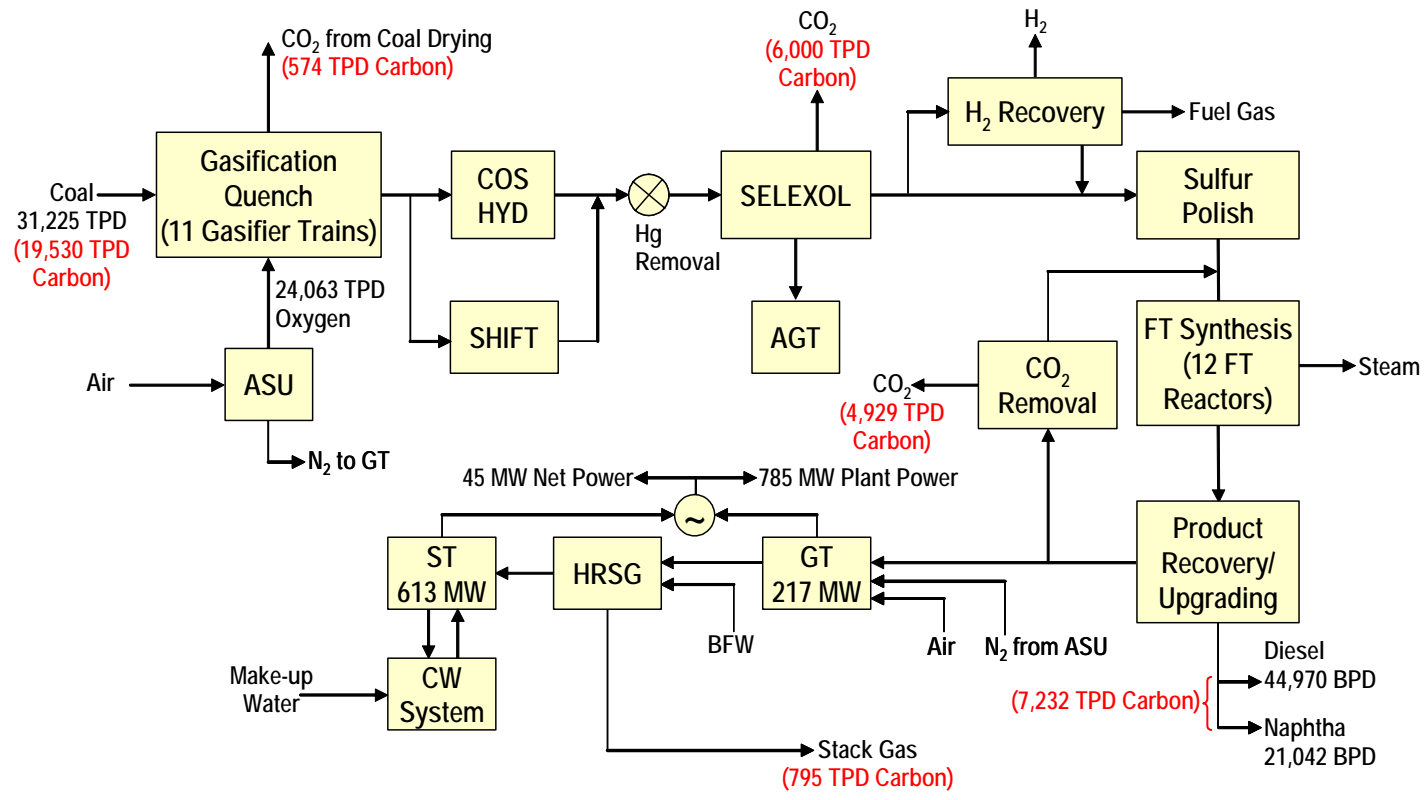

Figure 11. Case 9 – 60,000 BPD, Subbituminous Coal, with Recycle

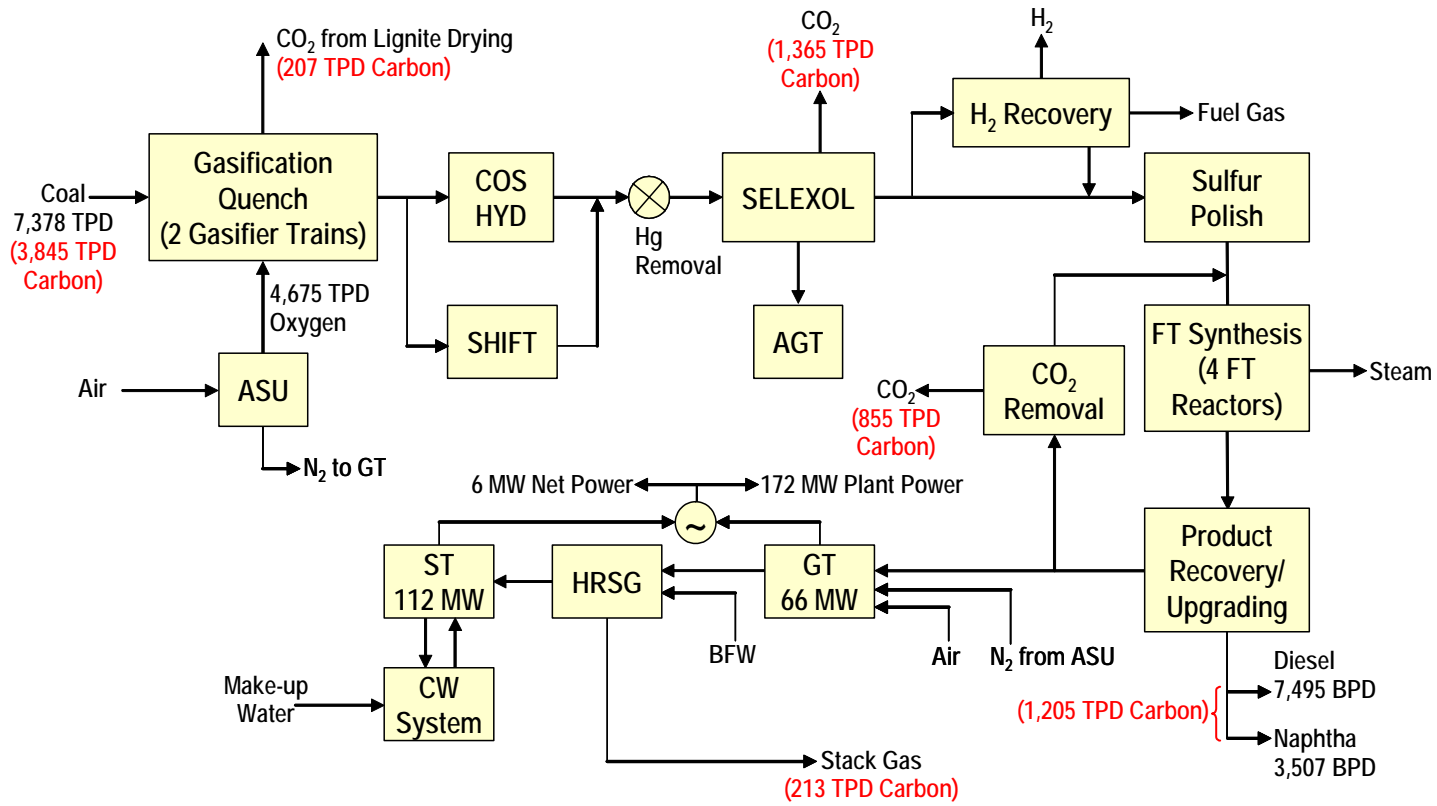

Figure 12. Case 10 – 10,000 BPD, Lignite, with Recycle

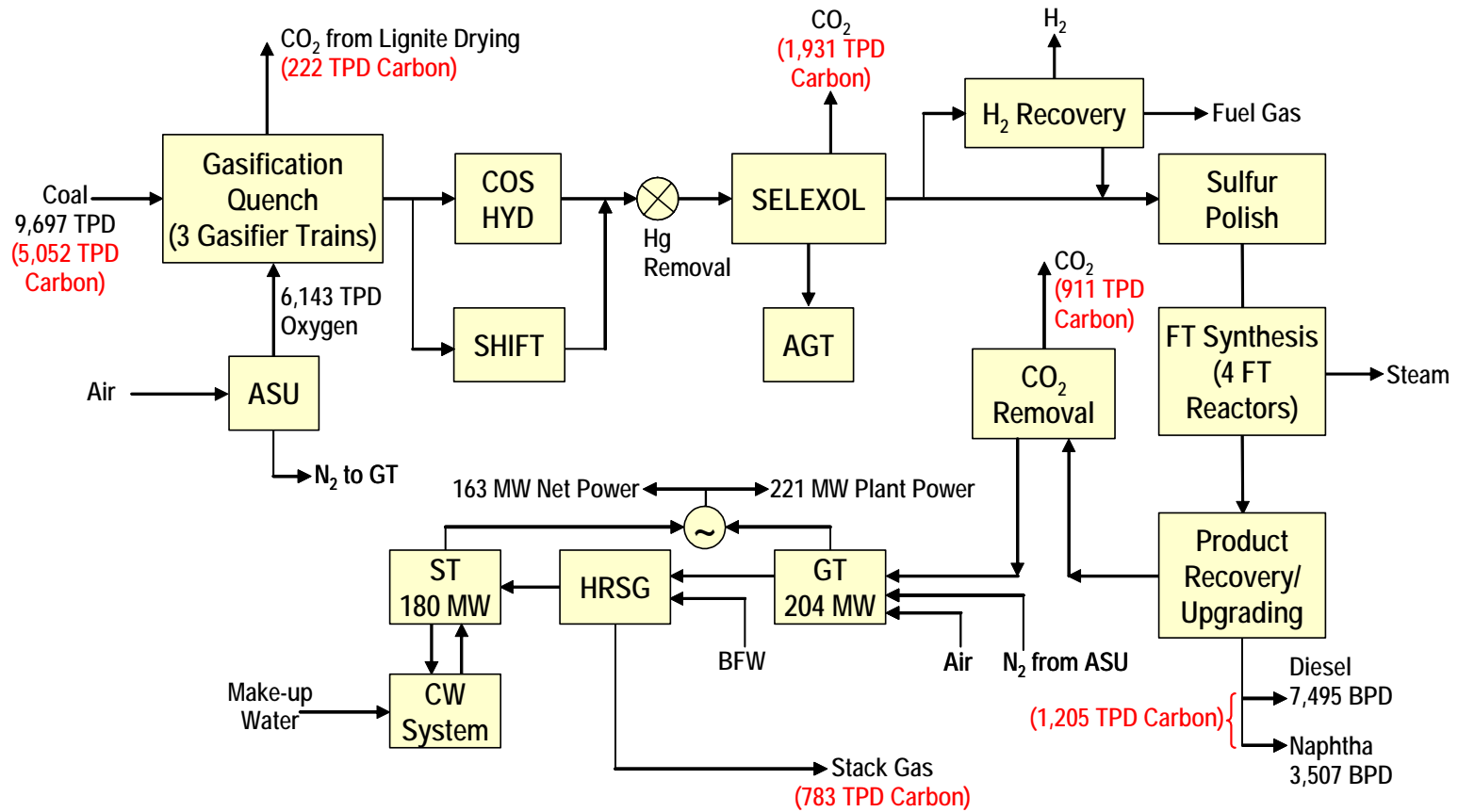

Figure 13. Case 11 – 10,000 BPD, Lignite, Once-Through

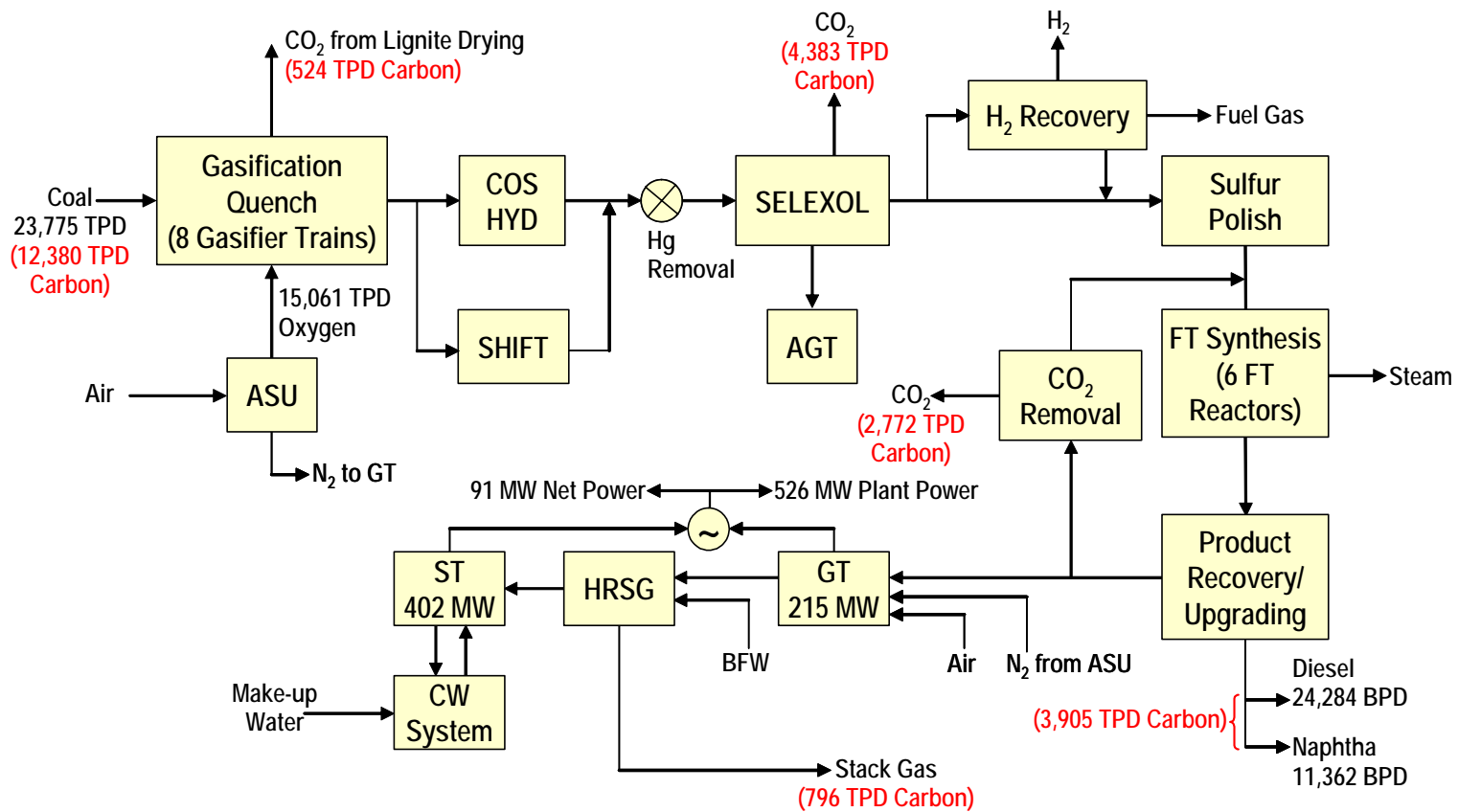

Figure 14. Case 12 – 30,000 BPD, Lignite, with Recycle

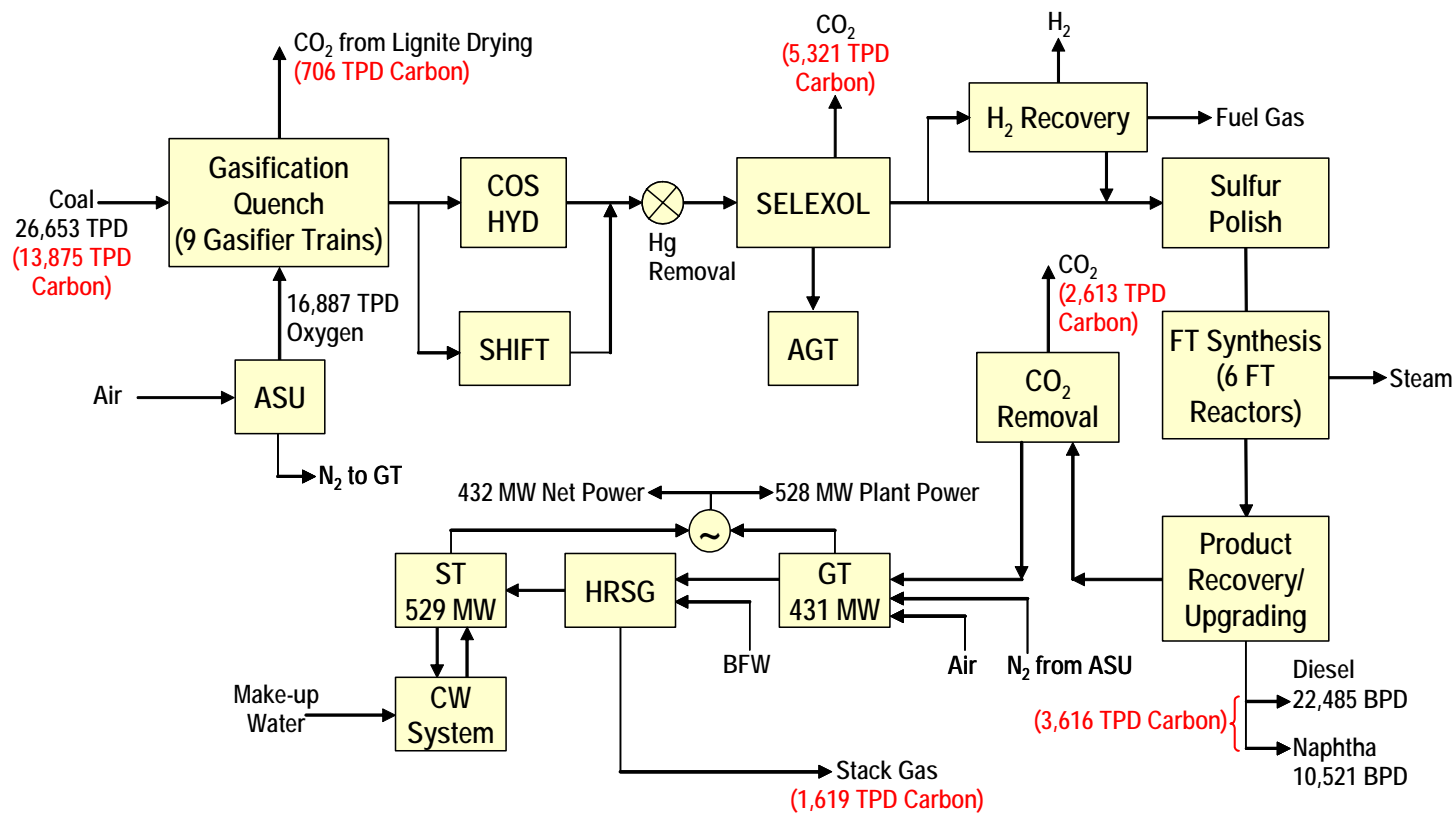

Figure 15. Case 13 – 30,000 BPD, Lignite, Once-Through, ~430 MW Net Power

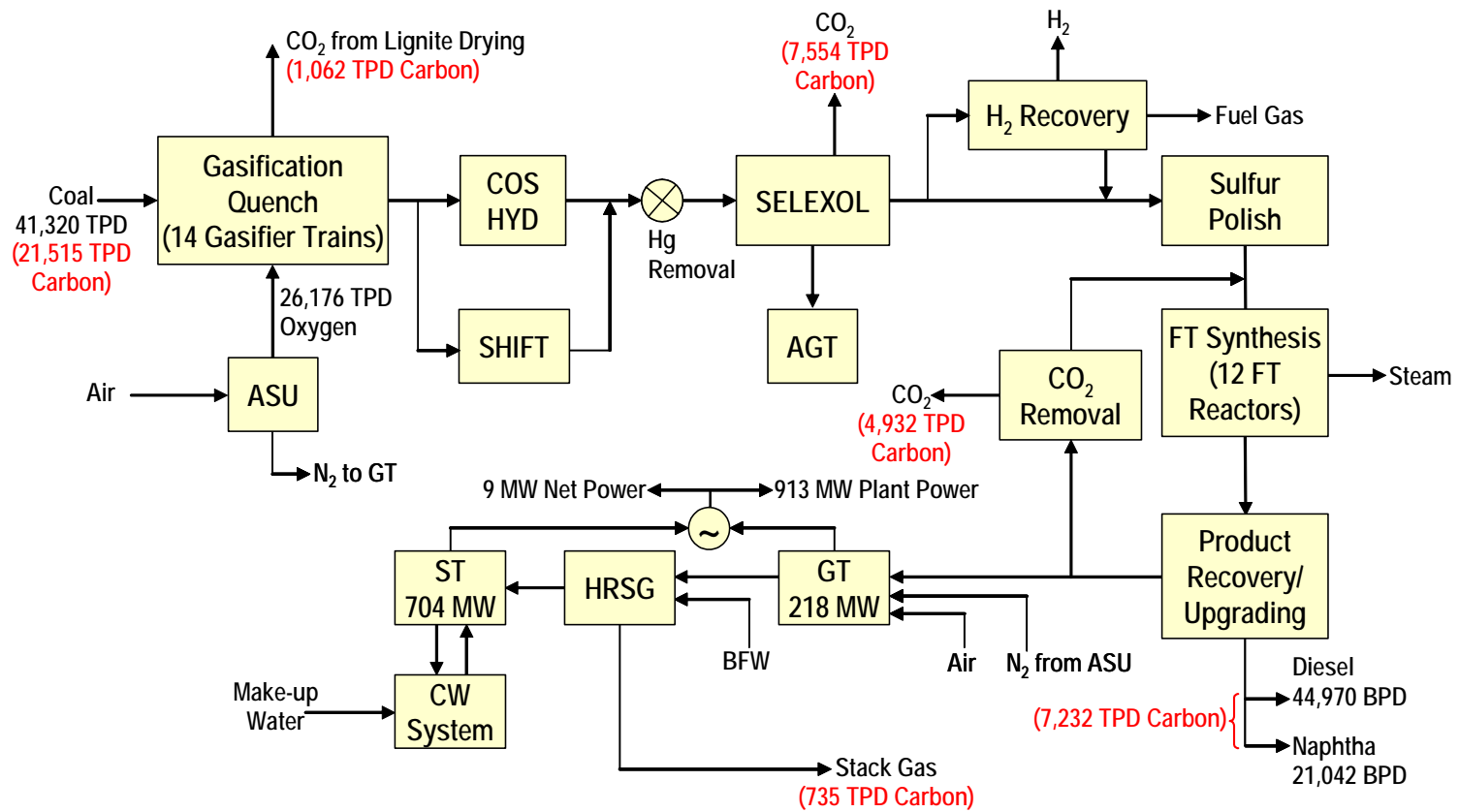

Figure 16. Case 14 – 60,000 BPD, Lignite, with Recycle

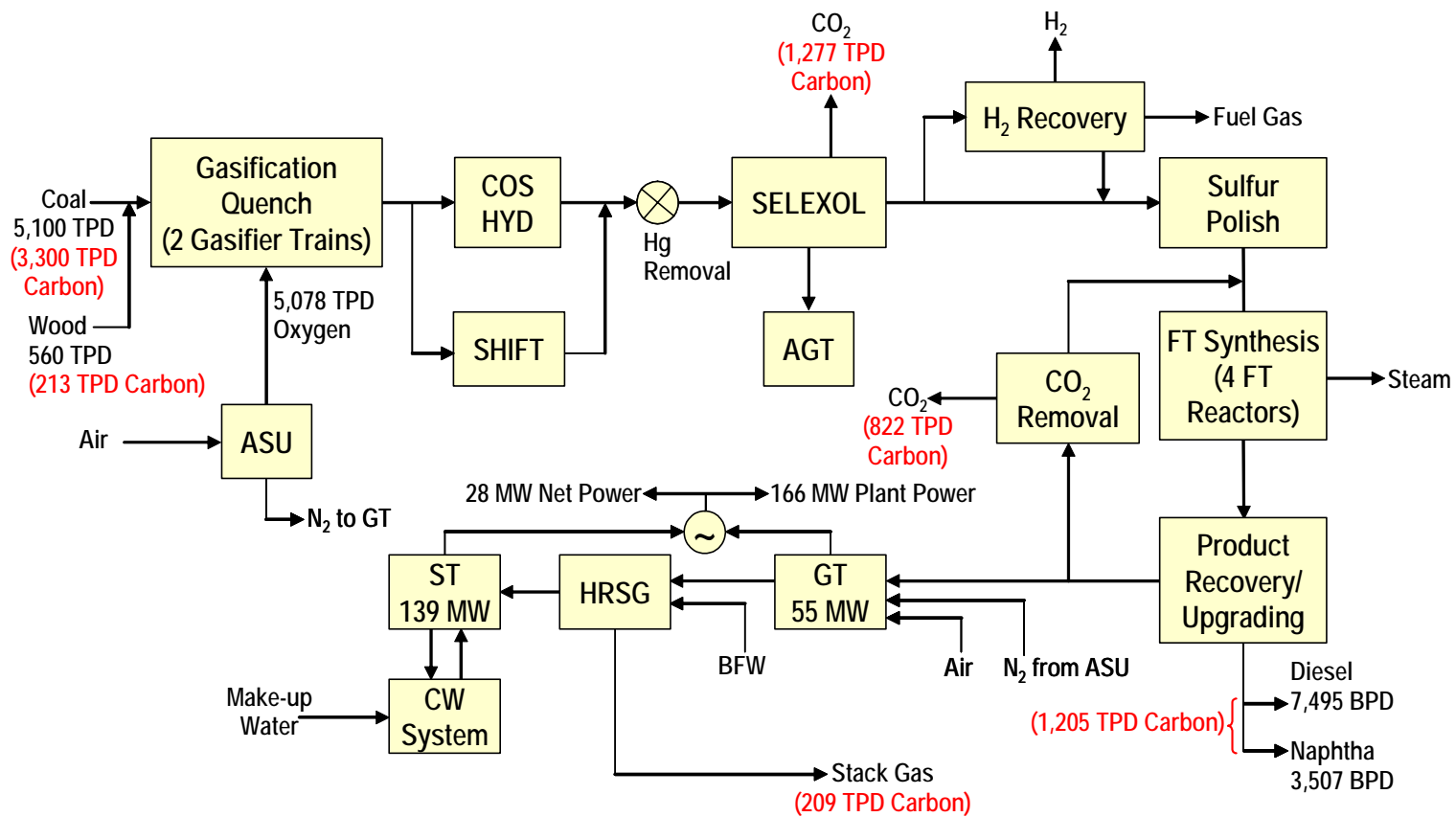

Figure 17. Case 15 – 10,000 BPD, Bituminous Coal and 10% Woody Biomass, with Recycle

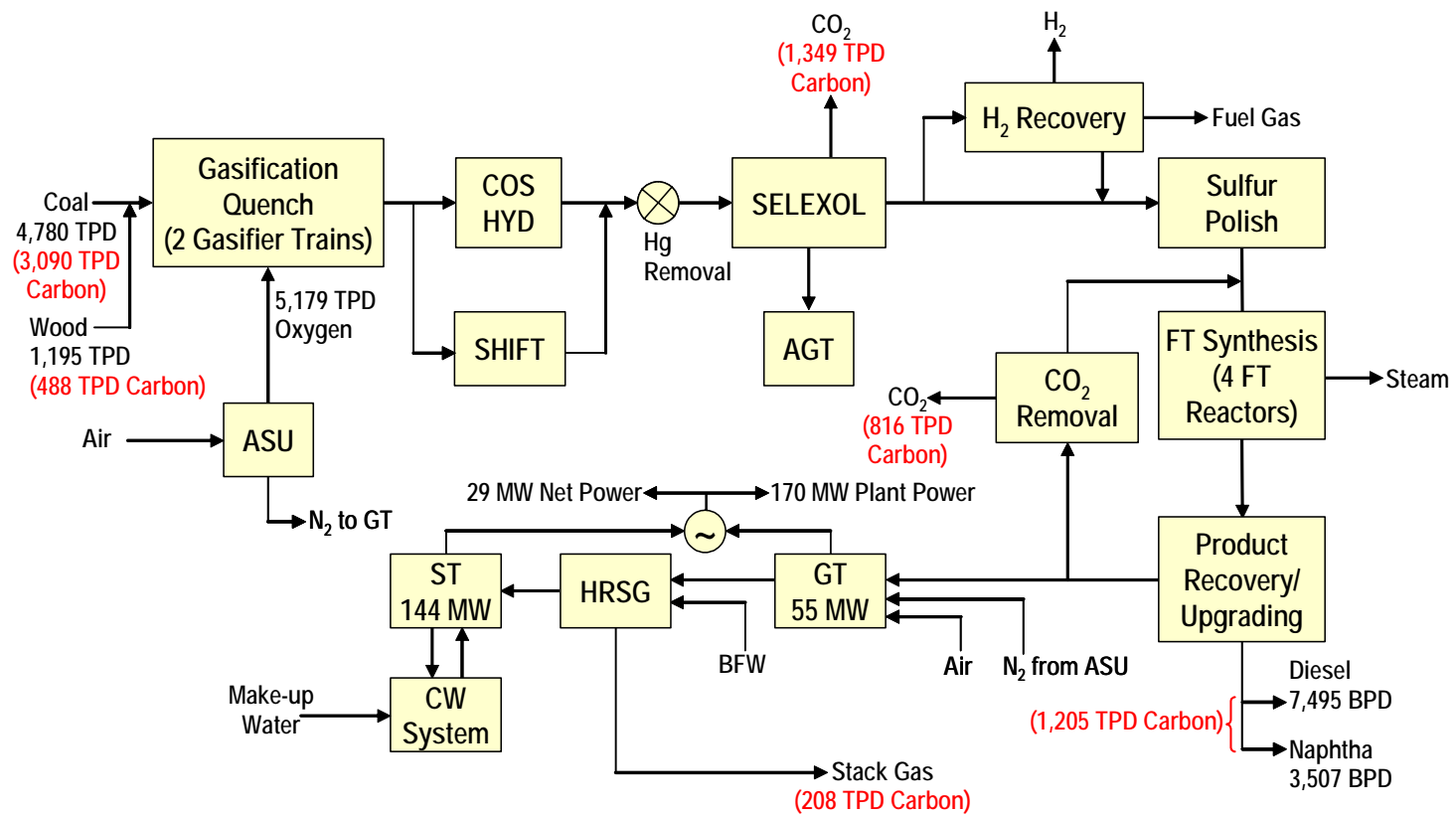

Figure 18. Case 16 – 10,000 BPD, Bituminous Coal and 20% Woody Biomass, with Recycle

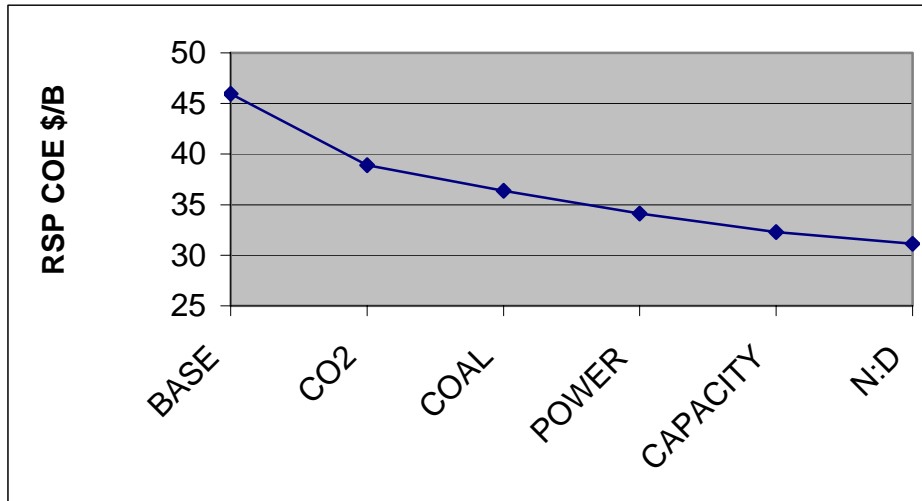

Figure 19: Sensitivities that would reduce the RSP

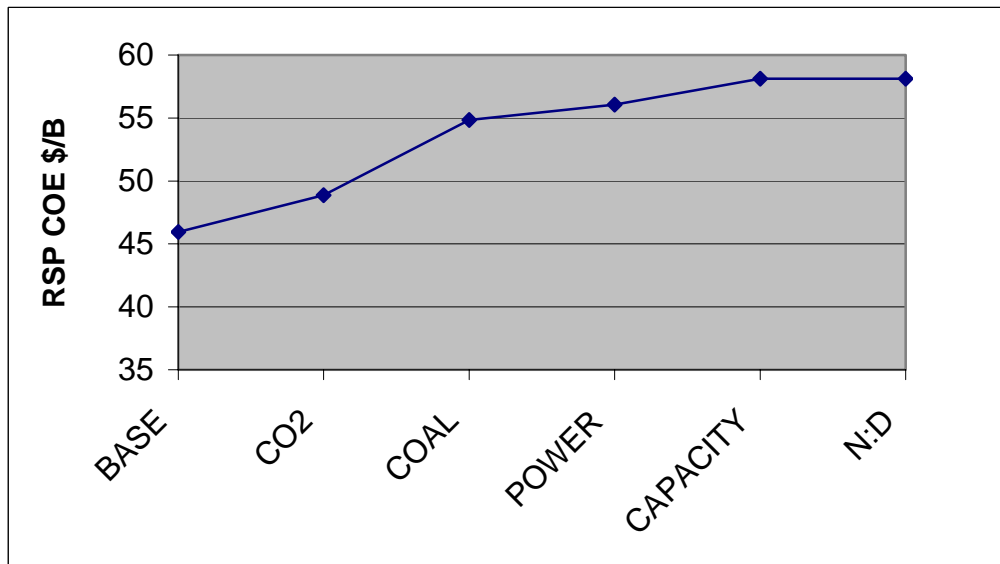

Figure 20: Sensitivities that would increase the RSP

Table 1. Case Studies

| Case Number | Capacity (BPD) | Configuration | Coal Type |
|-------------|----------------|---------------|-------------------------|
| 1 | 10,000 | Recycle | Bituminous |
| 2 | 10,000 | Once-through | Bituminous |
| 3 | 30,000 | Recycle | Bituminous |
| 4 | 30,000 | Once-through | Bituminous |
| 5 | 60,000 | Recycle | Bituminous |
| 6 | 10,000 | Recycle | Subbituminous |
| 7 | 10,000 | Once-through | Subbituminous |
| 8 | 30,000 | Recycle | Subbituminous |
| 9 | 60,000 | Recycle | Subbituminous |
| 10 | 10,000 | Recycle | Lignite |
| 11 | 10,000 | Once-through | Lignite |
| 12 | 30,000 | Recycle | Lignite |
| 13 | 30,000 | Once-through | Lignite |
| 14 | 60,000 | Recycle | Lignite |
| 15 | 10,000 | Recycle | Bituminous, 10% biomass |
| 16 | 10,000 | Recycle | Bituminous, 20% biomass |

Table 2. Bituminous Coal Analysis

| | DRY | AR | MAF |
|-----------|--------|--------|--------|
| C | 70.65 | 64.82 | 81.77 |
| H | 4.75 | 4.36 | 5.50 |
| N | 1.35 | 1.24 | 1.56 |
| CL | 0.20 | 0.18 | 0.23 |
| S | 3.20 | 2.94 | 3.70 |
| O | 6.25 | 5.73 | 7.23 |
| ASH | 13.60 | 12.48 | 15.74 |
| MOISTURE | | 8.25 | 0.00 |
| | 100.00 | 100.00 | 115.74 |
| BTU/(HHV) | 12862 | 11800 | 14886 |

Table 3. Subbituminous Coal Analysis

| | DRY | AR | MAF | AF |
|----------|--------|--------|--------|-------|
| C | 70.20 | 49.21 | 75.48 | 63.18 |
| H | 5.00 | 3.51 | 5.38 | 4.50 |
| N | 1.00 | 0.70 | 1.08 | 0.90 |
| CL | 0.01 | 0.01 | 0.01 | 0.01 |
| S | 0.50 | 0.35 | 0.54 | 0.45 |
| O | 16.29 | 11.42 | 17.52 | 14.66 |
| ASH | 7.00 | 4.91 | 7.53 | 6.30 |
| MOISTURE | | 29.90 | 0.00 | 10.00 |
| | 100.00 | 100.00 | 107.53 | 100 |
| BTU/#HHV | 12125 | 8500 | 13038 | 10913 |

Table 4. Lignite Coal Analysis

| | DRY | AR | MAF | AF |
|----------|--------|--------|--------|--------|
| C | 58.40 | 37.08 | 69.11 | 52.56 |
| H | 4.20 | 2.67 | 4.97 | 3.78 |
| N | 0.80 | 0.51 | 0.95 | 0.72 |
| CL | 0.06 | 0.04 | 0.07 | 0.05 |
| S | 1.87 | 1.19 | 2.21 | 1.68 |
| O | 19.17 | 12.17 | 22.69 | 17.25 |
| ASH | 15.50 | 9.84 | 18.34 | 13.95 |
| MOISTURE | | 36.50 | 0.00 | 10.00 |
| | 100.00 | 100.00 | 118.34 | 100.00 |
| BTU/#HHV | 9975 | 6334 | 11805 | 8978 |

Table 5. Woody Biomass Analysis

| | DRY | AF |
|----------|--------|--------|
| C | 48.45 | 41.18 |
| H | 5.85 | 4.97 |
| N | 0.47 | 0.40 |
| CL | 0.10 | 0.09 |
| S | 0.01 | 0.01 |
| O | 43.69 | 37.14 |
| ASH | 1.43 | 1.22 |
| MOISTURE | 0.00 | 15.00 |
| | 100.00 | 100.00 |
| BTU | 8358 | 7104 |

Table 6. Capital Equipment Costs (MM\$) for Bituminous Coal Cases

| | Case 1 | Case 2 | Case 3 | Case 4 | Case 5 |
|--------------------------------|--------------------------|----------------------------------|--------------------------|----------------------------------|--------------------------|
| | 10,000 BPD Recycle | 10,000 BPD Once through | 30,000 BPD Recycle | 30,000 BPD Once through | 60,000 BPD Recycle |
| Solids Handling | 58 | 77 | 163 | 175 | 278 |
| Gasification | 190 | 276 | 545 | 626 | 1,051 |
| Air Separation Unit | 92 | 121 | 256 | 274 | 436 |
| Gas Cleanup | 104 | 135 | 294 | 315 | 500 |
| CO ₂ Capture | 44 | 55 | 136 | 86 | 240 |
| Fischer-Tropsch | 95 | 95 | 279 | 260 | 469 |
| Power Block | 155 | 275 | 435 | 552 | 739 |
| Balance of Plant | 46 | 46 | 116 | 113 | 195 |
| Total Capital Equipment | 784 | 1,080 | 2,224 | 2,401 | 3,908 |

Table 7. Additional Capital Costs (MM\$) for Bituminous Coal Cases

| | Case 1 | Case 2 | Case 3 | Case 4 | Case 5 |
|----------------------------------|--------------------------|----------------------------------|--------------------------|----------------------------------|--------------------------|
| | 10,000 BPD Recycle | 10,000 BPD Once through | 30,000 BPD Recycle | 30,000 BPD Once through | 60,000 BPD Recycle |
| Home Office | 66 | 91 | 187 | 202 | 328 |
| Process Contingency | 0 | 0 | 0 | 0 | 0 |
| Project Contingency | 39 | 54 | 111 | 120 | 195 |
| License Fees | 25 | 25 | 25 | 25 | 25 |
| Financing / Legal | 25 | 25 | 25 | 25 | 25 |
| Non-depreciable Capital | 38 | 51 | 106 | 115 | 187 |
| Total Capital Equipment | 784 | 1,080 | 2,224 | 2,401 | 3,908 |
| Total Capital Requirement | 977 | 1,326 | 2,678 | 2,888 | 4,668 |

Table 8. Annual Operating Costs (MM\$/yr) for Bituminous Coal Cases

| | Case 1 | Case 2 | Case 3 | Case 4 | Case 5 |
|----------------------------|--------------------------|----------------------------------|--------------------------|----------------------------------|--------------------------|
| | 10,000 BPD Recycle | 10,000 BPD Once through | 30,000 BPD Recycle | 30,000 BPD Once through | 60,000 BPD Recycle |
| Royalties | 4.3 | 4.3 | 4.3 | 4.3 | 4.3 |
| Coal feed | 63.7 | 87.9 | 212.7 | 230.8 | 397.8 |
| Catalyst / Chemicals | 8.0 | 9.3 | 24.4 | 24.1 | 44.2 |
| Labor / Overhead | 18.2 | 24.8 | 50.1 | 54.0 | 87.3 |
| Administrative | 3.0 | 4.0 | 8.1 | 8.7 | 14.1 |
| Local Taxes & Insurance | 18.8 | 25.5 | 51.4 | 55.5 | 89.6 |
| Maintenance & Materials | 7.8 | 10.8 | 22.2 | 24.0 | 39.1 |
| Other Operating Costs | 3.4 | 4.2 | 0.0 | 10.2 | 17.4 |
| Gross Annual Op Costs | 127.2 | 170.8 | 373.2 | 411.6 | 693.8 |
| Byproduct credit | 4.1 | 5.7 | 13.8 | 15.0 | 25.9 |
| Net Annual Op Costs | 123.1 | 165.1 | 359.4 | 396.6 | 667.9 |

Table 9. Inputs and Outputs for Bituminous Coal Cases

| | Case 1 | Case 2 | Case 3 | Case 4 | Case 5 |
|-----------------------------------|--------------------------|----------------------------------|--------------------------|----------------------------------|--------------------------|
| | 10,000 BPD Recycle | 10,000 BPD Once through | 30,000 BPD Recycle | 30,000 BPD Once through | 60,000 BPD Recycle |
| Coal feed (TPD as received) | 5,386 | 7,435 | 17,987 | 19,517 | 33,640 |
| Naptha (BPD) | 3,507 | 3,507 | 11,398 | 10,521 | 21,042 |
| Diesel (BPD) | 7,495 | 7,495 | 24,359 | 22,485 | 44,970 |
| Naphtha & Diesel (BPD) | 11,002 | 11,002 | 35,757 | 33,006 | 66,012 |
| Equivalent Diesel (BPD) | 10,000 | 10,000 | 32,502 | 30,001 | 60,002 |
| Net Power Sales (MWe) | 27 | 241 | 204 | 537 | 386 |
| Gross Power (MWe) | 190 | 456 | 725 | 1,044 | 1,360 |
| Parasitic Power (MWe) | 163 | 216 | 520 | 508 | 973 |
| Sulfur (TPD) | 157 | 217 | 526 | 571 | 984 |
| CO ₂ for capture (TPD) | 7,408 | 9,586 | 24,734 | 25,903 | 46,099 |
| Coal HHV (MMBtu/D) | 127,110 | 175,466 | 424,493 | 460,601 | 793,904 |
| Products HHV (MMBtu/D) | 59,913 | 77,401 | 204,194 | 216,983 | 377,693 |
| Overall Efficiency (HHV) | 47.1% | 44.1% | 48.1% | 47.1% | 47.6% |

Table 10. Economic Summary for Bituminous Coal Cases

| | Case 1 | Case 2 | Case 3 | Case 4 | Case 5 |
|---|--------------------------|----------------------------------|--------------------------|----------------------------------|--------------------------|
| | 10,000 BPD Recycle | 10,000 BPD Once through | 30,000 BPD Recycle | 30,000 BPD Once through | 60,000 BPD Recycle |
| Capital (\$/DB) | 88,700 | 120,400 | 74,900 | 87,500 | 70,700 |
| Annualized Capital (MM\$/yr, \$/B) | 119.01 36.23 | 161.65 49.21 | 335.80 31.45 | 351.95 35.71 | 568.53 28.84 |
| Coal feed (MM\$/yr, \$/B) | 63.69 19.39 | 87.93 26.76 | 212.71 19.92 | 230.81 23.42 | 397.83 20.18 |
| Net O&M Costs (less coal) (MM\$/yr, \$/B) | 59.40 18.08 | 77.20 23.50 | 146.70 13.74 | 165.80 16.82 | 270.10 13.70 |
| Total Annual Costs (MM\$/yr, \$/B) | 242.10 73.70 | 326.78 99.47 | 695.22 65.11 | 748.55 75.95 | 1,236.46 62.73 |
| Net Power Sales (MM\$/yr, \$/B) | 7.66 2.33 | 67.59 20.57 | 57.37 5.37 | 150.61 15.28 | 108.39 5.50 |
| Diesel Req Selling Price (MM\$/yr, \$/B) | 234.44 71.36 | 259.19 78.90 | 637.85 59.74 | 597.95 60.67 | 1,128.06 57.23 |
| COE Req Selling Price (MM\$/yr, \$/B) | 180.34 54.90 | 199.38 60.69 | 490.65 45.96 | 459.96 46.67 | 867.74 44.02 |

Table 11. Capital Equipment Costs (MM\$) for Subbituminous Coal Cases

| | Case 6 | Case 7 | Case 8 | Case 9 |
|--------------------------------|--------------------------|----------------------------------|--------------------------|--------------------------|
| | 10,000 BPD Recycle | 10,000 BPD Once through | 30,000 BPD Recycle | 60,000 BPD Recycle |
| Solids Handling | 68 | 89 | 189 | 304 |
| Gasification | 176 | 258 | 512 | 921 |
| Air Separation Unit | 76 | 96 | 178 | 263 |
| Gas Cleanup | 107 | 140 | 302 | 484 |
| CO ₂ Capture | 39 | 49 | 121 | 203 |
| Fischer-Tropsch | 95 | 95 | 275 | 469 |
| Power Block | 166 | 235 | 415 | 601 |
| Balance of Plant | 46 | 46 | 115 | 195 |
| Total Capital Equipment | 773 | 1,008 | 2,107 | 3,440 |

Table 12. Additional Capital Costs (MM\$) for Subbituminous Coal Cases

| | Case 6 | Case 7 | Case 8 | Case 9 |
|----------------------------------|--------------------------|----------------------------------|--------------------------|--------------------------|
| | 10,000 BPD Recycle | 10,000 BPD Once through | 30,000 BPD Recycle | 60,000 BPD Recycle |
| Home Office | 65 | 85 | 177 | 289 |
| Process Contingency | 0 | 0 | 0 | 0 |
| Project Contingency | 39 | 50 | 105 | 172 |
| License Fees | 25 | 25 | 25 | 25 |
| Financing / Legal | 25 | 25 | 25 | 25 |
| Non-depreciable Capital | 35 | 44 | 91 | 149 |
| Total Capital Equipment | 773 | 1,008 | 2,107 | 3,440 |
| Total Capital Requirement | 962 | 1,237 | 2,530 | 4,100 |

Table 13. Annual Operating Costs (MM\$/yr) for Subbituminous Coal Cases

| | Case 6 | Case 7 | Case 8 | Case 9 |
|----------------------------|--------------------------|----------------------------------|--------------------------|--------------------------|
| | 10,000 BPD Recycle | 10,000 BPD Once through | 30,000 BPD Recycle | 60,000 BPD Recycle |
| Royalties | 4.3 | 4.3 | 4.3 | 4.3 |
| Coal feed | 24.8 | 34.2 | 83.1 | 144.9 |
| Catalyst / Chemicals | 8.8 | 10.0 | 26.3 | 46.8 |
| Labor / Overhead | 17.9 | 23.1 | 47.3 | 76.6 |
| Administrative | 2.9 | 3.7 | 7.7 | 12.4 |
| Local Taxes & Insurance | 18.5 | 23.9 | 48.8 | 79.0 |
| Maintenance & Materials | 7.7 | 10.1 | 21.1 | 34.4 |
| Other Operating Costs | 1.8 | 2.1 | 4.3 | 7.1 |
| Gross Annual Op Costs | 86.7 | 111.4 | 242.9 | 405.5 |
| Byproduct credit | 0.6 | 0.9 | 2.1 | 3.7 |
| Net Annual Op Costs | 86.1 | 110.5 | 240.8 | 401.8 |

Table 14. Inputs and Outputs for Subbituminous Coal Cases

| | Case 6 | Case 7 | Case 8 | Case 9 |
|-----------------------------------|--------------------------|----------------------------------|--------------------------|--------------------------|
| | 10,000 BPD Recycle | 10,000 BPD Once through | 30,000 BPD Recycle | 60,000 BPD Recycle |
| Coal feed (TPD as received) | 6,866 | 9,454 | 22,988 | 40,089 |
| Coal feed (TPD as fed) | 5,348 | 7,364 | 17,905 | 31,225 |
| Naptha (BPD) | 3,507 | 3,507 | 11,222 | 21,042 |
| Diesel (BPD) | 7,495 | 7,495 | 23,984 | 44,970 |
| Naphtha & Diesel (BPD) | 11,002 | 11,002 | 35,206 | 66,012 |
| Equivalent Diesel (BPD) | 10,000 | 10,000 | 32,001 | 60,002 |
| Net Power Sales (MWe) | 19 | 162 | 146 | 44 |
| Gross Power (MWe) | 162 | 353 | 597 | 829 |
| Parasitic Power (MWe) | 143 | 191 | 451 | 784 |
| Sulfur (TPD) | 24 | 33 | 80 | 140 |
| CO ₂ for capture (TPD) | 6,833 | 9,194 | 22,834 | 39,984 |
| Coal HHV (MMBtu/D) | 116,722 | 160,718 | 390,796 | 681,513 |
| Products HHV (MMBtu/D) | 59,208 | 70,979 | 196,538 | 349,704 |
| Overall Efficiency (HHV) | 50.7% | 44.2% | 50.3% | 51.3% |

Table 15. Economic Summary for Subbituminous Coal Cases

| | Case 6 | Case 7 | Case 8 | Case 9 |
|---|--------------------------|----------------------------------|--------------------------|--------------------------|
| | 10,000 BPD Recycle | 10,000 BPD Once through | 30,000 BPD Recycle | 60,000 BPD Recycle |
| Capital (\$/DB) | 87,300 | 112,400 | 71,900 | 62,100 |
| Annualized Capital (MM\$/yr, \$/B) | 116.83 35.56 | 150.79 45.90 | 307.79 29.28 | 497.93 25.26 |
| Coal feed (MM\$/yr, \$/B) | 24.81 7.55 | 34.16 10.40 | 83.07 7.90 | 144.86 7.35 |
| Net O&M Costs (less coal) (MM\$/yr, \$/B) | 61.30 18.66 | 76.30 23.22 | 157.70 15.00 | 256.90 13.03 |
| Total Annual Costs (MM\$/yr, \$/B) | 202.94 61.78 | 261.25 79.53 | 548.55 52.18 | 899.69 45.64 |
| Net Power Sales (MM\$/yr, \$/B) | 5.25 1.60 | 45.58 13.87 | 41.03 3.90 | 12.49 0.63 |
| Diesel Req Selling Price (MM\$/yr, \$/B) | 197.69 60.18 | 215.67 65.65 | 507.52 48.28 | 887.20 45.01 |
| COE Req Selling Price (MM\$/yr, \$/B) | 152.07 46.29 | 165.90 50.50 | 390.40 37.14 | 682.46 34.62 |

Table 16. Capital Equipment Costs (MM\$) for Lignite Cases

| | Case 10 | Case 11 | Case 12 | Case 13 | Case 14 |
|--------------------------------|--------------------------|----------------------------------|--------------------------|----------------------------------|--------------------------|
| | 10,000 BPD Recycle | 10,000 BPD Once through | 30,000 BPD Recycle | 30,000 BPD Once through | 60,000 BPD Recycle |
| Solids Handling | 97 | 122 | 262 | 289 | 420 |
| Gasification | 238 | 308 | 725 | 811 | 1,238 |
| Air Separation Unit | 83 | 101 | 189 | 205 | 279 |
| Gas Cleanup | 122 | 155 | 334 | 368 | 535 |
| CO ₂ Capture | 44 | 54 | 134 | 80 | 223 |
| Fischer-Tropsch | 95 | 95 | 278 | 260 | 469 |
| Power Block | 180 | 275 | 436 | 590 | 633 |
| Balance of Plant | 46 | 46 | 115 | 113 | 195 |
| Total Capital Equipment | 905 | 1,156 | 2,473 | 2,716 | 3,992 |

Table 17. Additional Capital Costs (MM\$) for Lignite Cases

| | Case 10 | Case 11 | Case 12 | Case 13 | Case 14 |
|----------------------------------|--------------------------|----------------------------------|--------------------------|----------------------------------|--------------------------|
| | 10,000 BPD Recycle | 10,000 BPD Once through | 30,000 BPD Recycle | 30,000 BPD Once through | 60,000 BPD Recycle |
| Home Office | 76 | 97 | 208 | 228 | 335 |
| Process Contingency | 0 | 0 | 0 | 0 | 0 |
| Project Contingency | 45 | 58 | 124 | 136 | 200 |
| License Fees | 25 | 25 | 25 | 25 | 25 |
| Financing / Legal | 25 | 25 | 25 | 25 | 25 |
| Non-depreciable Capital | 40 | 51 | 109 | 120 | 176 |
| Total Capital Equipment | 905 | 1,156 | 2,473 | 2,716 | 3,992 |
| Total Capital Requirement | 1,116 | 1,412 | 2,964 | 3,250 | 4,753 |

Table 18. Annual Operating Costs (MM\$/yr) for Lignite Cases

| | Case 10 | Case 11 | Case 12 | Case 13 | Case 14 |
|----------------------------|--------------------------|----------------------------------|--------------------------|----------------------------------|--------------------------|
| | 10,000 BPD Recycle | 10,000 BPD Once through | 30,000 BPD Recycle | 30,000 BPD Once through | 60,000 BPD Recycle |
| Royalties | 4.3 | 4.3 | 4.3 | 4.3 | 4.3 |
| Coal feed | 34.4 | 45.1 | 110.7 | 124.1 | 192.4 |
| Catalyst / Chemicals | 9.5 | 10.7 | 28.3 | 28.4 | 49.5 |
| Labor / Overhead | 20.9 | 26.4 | 55.4 | 60.8 | 88.8 |
| Administrative | 3.4 | 4.3 | 9.0 | 9.8 | 14.4 |
| Local Taxes & Insurance | 21.5 | 27.2 | 57.1 | 62.6 | 91.5 |
| Maintenance & Materials | 9.0 | 11.5 | 24.7 | 27.2 | 39.9 |
| Other Operating Costs | 4.0 | 5.0 | 11.6 | 12.9 | 19.6 |
| Gross Annual Op Costs | 192.9 | 134.5 | 301.1 | 330.1 | 500.4 |
| Byproduct credit | 3.3 | 4.3 | 10.5 | 11.7 | 18.2 |
| Net Annual Op Costs | 189.6 | 130.2 | 290.6 | 318.4 | 482.2 |

Table 19. Inputs and Outputs for Lignite Cases

| | Case 10 | Case 11 | Case 12 | Case 13 | Case 14 |
|-----------------------------------|--------------------------|----------------------------------|--------------------------|----------------------------------|--------------------------|
| | 10,000 BPD Recycle | 10,000 BPD Once through | 30,000 BPD Recycle | 30,000 BPD Once through | 60,000 BPD Recycle |
| Coal feed (TPD as received) | 10,459 | 13,744 | 33,697 | 37,780 | 58,564 |
| Coal feed (TPD as fed) | 7,379 | 9,697 | 23,775 | 26,656 | 41,320 |
| Naptha (BPD) | 3,507 | 3,507 | 11,362 | 10,521 | 21,042 |
| Diesel (BPD) | 7,495 | 7,495 | 24,284 | 22,485 | 44,970 |
| Naphtha & Diesel (BPD) | 11,002 | 11,002 | 35,646 | 33,006 | 66,012 |
| Equivalent Diesel (BPD) | 10,000 | 10,000 | 32,401 | 30,001 | 60,002 |
| Net Power Sales (MWe) | 6 | 163 | 91 | 432 | 9 |
| Gross Power (MWe) | 178 | 384 | 617 | 960 | 922 |
| Parasitic Power (MWe) | 172 | 221 | 526 | 528 | 912 |
| Sulfur (TPD) | 124 | 163 | 399 | 447 | 693 |
| CO ₂ for capture (TPD) | 8,125 | 10,399 | 26,180 | 29,032 | 45,686 |
| Coal HHV (MMBtu/D) | 132,495 | 174,109 | 426,874 | 478,597 | 741,889 |
| Products HHV (MMBtu/D) | 58,160 | 71,036 | 194,291 | 208,391 | 346,804 |
| Overall Efficiency (HHV) | 43.9% | 40.8% | 45.5% | 43.5% | 46.7% |

Table 20. Economic Summary for Lignite Cases

| | Case 10 | Case 11 | Case 12 | Case 13 | Case 14 |
|---|--------------------------|----------------------------------|--------------------------|----------------------------------|--------------------------|
| | 10,000 BPD Recycle | 10,000 BPD Once through | 30,000 BPD Recycle | 30,000 BPD Once through | 60,000 BPD Recycle |
| Capital (\$/DB) | 101,500 | 128,200 | 83,100 | 98,500 | 72,000 |
| Annualized Capital (MM\$/yr, \$/B) | 135.84 41.35 | 171.72 52.27 | 359.57 33.78 | 394.79 40.06 | 575.88 29.22 |
| Coal feed (MM\$/yr, \$/B) | 34.36 10.46 | 45.15 13.74 | 110.69 10.40 | 124.11 12.59 | 192.38 9.76 |
| Net O&M Costs (less coal) (MM\$/yr, \$/B) | 69.40 21.13 | 85.20 25.93 | 179.90 16.90 | 194.30 19.71 | 289.80 14.70 |
| Total Annual Costs (MM\$/yr, \$/B) | 239.59 72.93 | 302.07 91.95 | 650.16 61.08 | 713.19 72.37 | 1,058.06 53.68 |
| Net Power Sales (MM\$/yr, \$/B) | 1.66 0.50 | 45.78 13.93 | 25.43 2.39 | 121.17 12.29 | 2.55 0.13 |
| Diesel Req Selling Price (MM\$/yr, \$/B) | 237.94 72.43 | 256.29 78.02 | 624.74 58.70 | 592.03 60.07 | 1,055.50 53.55 |
| COE Req Selling Price (MM\$/yr, \$/B) | 183.03 55.71 | 197.15 60.01 | 480.57 45.15 | 455.41 46.21 | 811.93 41.19 |

Table 21. Capital Equipment Costs (MM\$) for Bituminous Coal - Biomass Cases

| | Case 1 | Case 15 | Case 16 |
|--------------------------------|--|--|--|
| | 10,000 BPD Recycle 0% Biomass | 10,000 BPD Recycle 10% Biomass | 10,000 BPD Recycle 20% Biomass |
| Solids Handling | 58 | 61 | 64 |
| Gasification | 190 | 189 | 187 |
| Air Separation Unit | 92 | 93 | 95 |
| Gas Cleanup | 104 | 107 | 111 |
| CO ₂ Capture | 44 | 45 | 46 |
| Fischer-Tropsch | 95 | 95 | 95 |
| Power Block | 155 | 157 | 160 |
| Balance of Plant | 46 | 46 | 46 |
| Total Capital Equipment | 784 | 793 | 804 |

Table 22. Additional Capital Costs (MM\$) for Bituminous Coal - Biomass Cases

| | Case 1 | Case 15 | Case 16 |
|----------------------------------|--|--|--|
| | 10,000 BPD Recycle 0% Biomass | 10,000 BPD Recycle 10% Biomass | 10,000 BPD Recycle 20% Biomass |
| Home Office | 66 | 67 | 67 |
| Process Contingency | 0 | 0 | 0 |
| Project Contingency | 39 | 40 | 40 |
| License Fees | 25 | 25 | 25 |
| Financing / Legal | 25 | 25 | 25 |
| Non-depreciable Capital | 38 | 38 | 39 |
| Total Capital Equipment | 784 | 793 | 804 |
| Total Capital Requirement | 977 | 988 | 1,000 |

Table 23. Annual Operating Costs (MM\$/yr) for Bituminous Coal - Biomass Cases

| | Case 1 | Case 15 | Case 16 |
|----------------------------|--|--|--|
| | 10,000 BPD Recycle 0% Biomass | 10,000 BPD Recycle 10% Biomass | 10,000 BPD Recycle 20% Biomass |
| Royalties | 4.3 | 4.3 | 4.3 |
| Coal feed | 63.7 | 63.5 | 63.4 |
| Catalyst / Chemicals | 8.0 | 8.0 | 8.0 |
| Labor / Overhead | 18.2 | 18.2 | 18.2 |
| Administrative | 3.0 | 3.0 | 3.0 |
| Local Taxes & Insurance | 18.8 | 18.8 | 18.8 |
| Maintenance & Materials | 7.8 | 7.8 | 7.8 |
| Other Operating Costs | 3.4 | 3.4 | 3.4 |
| Gross Annual Op Costs | 127.2 | 127.0 | 126.9 |
| Byproduct credit | 4.1 | 3.9 | 3.7 |
| Net Annual Op Costs | 123.1 | 123.1 | 123.2 |

Table 24. Inputs and Outputs for Bituminous Coal - Biomass Cases

| | Case 1 | Case 15 | Case 16 |
|-----------------------------------|--|--|--|
| | 10,000 BPD Recycle 0% Biomass | 10,000 BPD Recycle 10% Biomass | 10,000 BPD Recycle 20% Biomass |
| Coal feed (TPD as received) | 5,386 | 5,100 | 4,780 |
| Wood feed (TPD as received) | 0 | 560 | 1,195 |
| Naptha (BPD) | 3,507 | 3,507 | 3,507 |
| Diesel (BPD) | 7,495 | 7,495 | 7,495 |
| Naptha & Diesel (BPD) | 11,002 | 11,002 | 11,002 |
| Equivalent Diesel (BPD) | 10,000 | 10,000 | 10,000 |
| Net Power Sales (MWe) | 27 | 28 | 29 |
| Gross Power (MWe) | 190 | 194 | 199 |
| Parasitic Power (MWe) | 163 | 166 | 170 |
| Sulfur (TPD) | 157 | 149 | 140 |
| CO ₂ for capture (TPD) | 7,408 | 7,680 | 7,923 |
| Coal HHV (MMBtu/D) | 127,110 | 128,316 | 129,787 |
| Products HHV (MMBtu/D) | 59,913 | 59,962 | 60,019 |
| Overall Efficiency (HHV) | 47.1% | 46.7% | 46.2% |

Table 25. Economic Summary for Bituminous Coal - Biomass Cases

| | Case 1 | Case 15 | Case 16 |
|---|--|--|--|
| | 10,000 BPD Recycle 0% Biomass | 10,000 BPD Recycle 10% Biomass | 10,000 BPD Recycle 20% Biomass |
| Capital (\$/DB) | 88,700 | 89,700 | 90,900 |
| Annualized Capital (MM\$/yr, \$/B) | 119.01 36.23 | 120.96 36.82 | 123.12 37.48 |
| Coal feed (MM\$/yr, \$/B) | 63.69 19.39 | 63.51 19.33 | 63.35 19.29 |
| Net O&M Costs (less coal) (MM\$/yr, \$/B) | 59.40 18.08 | 59.60 18.14 | 59.80 18.20 |
| Total Annual Costs (MM\$/yr, \$/B) | 242.10 73.70 | 244.08 74.30 | 246.27 74.97 |
| Net Power Sales (MM\$/yr, \$/B) | 7.66 2.33 | 7.83 2.38 | 8.03 2.44 |
| Diesel Req Selling Price (MM\$/yr, \$/B) | 234.44 71.36 | 236.25 71.91 | 238.24 72.52 |
| COE Req Selling Price (MM\$/yr, \$/B) | 180.34 54.90 | 181.73 55.32 | 183.26 55.79 |

Table 26. Parameters and Assumptions Used in Economic Analysis

| Economic Parameter / Assumption | Value |
|--|-------------------------------------|
| Construction Period | 3 years |
| Incurred Capital Cost Construction Year 1 | 20% |
| Incurred Capital Cost Construction Year 2 | 50% |
| Incurred Capital Cost Construction Year 3 | 30% |
| 1 st Year Availability | 45% |
| 2 nd Year Availability | 81% |
| 3 rd Year and Beyond Availability | 90% |
| Plant Lifetime | 25 years |
| Return on Equity | 15% |
| Depreciation Method | Double declining balance (16 years) |
| Debt:Equity Ratio | 67:33 |
| Interest Rate | 8% |
| Inflation Rate | 3% |
| Tax Rate | 36% |
| Electricity Selling Price | \$35.6 per MWhr |
| Sulfur Price | \$80 per ton |
| Bituminous Coal Price | \$36 per ton |
| Subbituminous Coal Price | \$11 per ton |
| Lignite Price | \$10 per ton |
| Woody Biomass Price | \$20 per ton dry |
| Naphtha Value | 0.714 times diesel value |

Table 27. Emissions Summaries for CO₂, NO_x, and SO_x

| Case Number | CO ₂ | | | | | NO _x | SO _x |
|-------------|-----------------|---------------|--------------|-----------------|------------|-----------------|-----------------|
| | Produced TPD | Emissions TPD | Captured TPD | Captured MMSCFD | Captured % | TPD | TPD |
| 1 | 8,177 | 770 | 7,407 | 127.4 | 91% | 0.093 | 0.019 |
| 2 | 12,934 | 3,348 | 9,586 | 164.9 | 74% | 0.354 | 0.026 |
| 3 | 27,887 | 3,153 | 24,734 | 425.4 | 89% | 0.363 | 0.063 |
| 4 | 32,587 | 6,684 | 25,903 | 445.5 | 79% | 1.455 | 0.069 |
| 5 | 52,505 | 6,406 | 46,099 | 792.8 | 88% | 1.441 | 0.118 |
| 6 | 7,526 | 693 | 6,833 | 117.5 | 91% | 0.091 | 0.003 |
| 7 | 12,039 | 2,845 | 9,194 | 158.1 | 76% | 0.321 | 0.004 |
| 8 | 25,870 | 3,036 | 22,834 | 392.7 | 88% | 0.368 | 0.010 |
| 9 | 42,899 | 2,915 | 39,984 | 687.6 | 93% | 0.371 | 0.017 |
| 10 | 8,906 | 781 | 8,125 | 139.7 | 91% | 0.095 | 0.015 |
| 11 | 13,270 | 2,871 | 10,399 | 178.8 | 78% | 0.320 | 0.020 |
| 12 | 29,099 | 2,919 | 26,180 | 450.2 | 90% | 0.353 | 0.048 |
| 13 | 34,968 | 5,936 | 29,032 | 499.3 | 83% | 0.680 | 0.054 |
| 14 | 48,381 | 2,695 | 45,686 | 785.7 | 94% | 0.741 | 0.083 |
| 15 | 8,446 | 766 | 7,680 | 132.1 | 91% | 0.093 | 0.018 |
| 16 | 8,686 | 763 | 7,923 | 136.3 | 91% | 0.093 | 0.017 |

Table 28. Summary of Results for Techno-economic Feasibility Study

| Case Number - Configuration | Diesel Production (BPD) | Exported Power (MW) | Capital Required (\$/DB) | Diesel RSP COE (\$/B) | Efficiency (% HHV) |
|------------------------------------|--------------------------------|----------------------------|---------------------------------|------------------------------|---------------------------|
| 1 – Bitumin, Recycle | 10,000 | 27 | 88,700 | 54.9 | 47.1 |
| 2 – Bitumin, Once-through | 10,000 | 241 | 120,400 | 60.69 | 44.1 |
| 3 – Bitumin, Recycle | 30,000 | 204 | 74,900 | 45.96 | 48.1 |
| 4 – Bitumin, Once-through | 30,000 | 537 | 87,500 | 46.67 | 47.1 |
| 5 - Bitumin, Recycle | 60,000 | 386 | 70,700 | 44.02 | 47.6 |
| 6 – Subbitum, Recycle | 10,000 | 19 | 87,300 | 46.29 | 50.7 |
| 7 – Subbitum, Once-through | 10,000 | 162 | 112,400 | 50.50 | 44.2 |
| 8 – Subbitum, Recycle | 30,000 | 146 | 71,900 | 37.14 | 50.3 |
| 9 – Subbitum, Recycle | 60,000 | 44 | 62,100 | 34.62 | 51.3 |
| 10 – Lignite, Recycle | 10,000 | 6 | 101,500 | 55.71 | 43.9 |
| 11 – Lignite, Once-through | 10,000 | 163 | 128,200 | 60.01 | 40.8 |
| 12 – Lignite, Recycle | 30,000 | 91 | 83,100 | 45.15 | 45.5 |
| 13 – Lignite, Once-through | 30,000 | 432 | 98,500 | 46.21 | 43.5 |
| 14 – Lignite, Recycle | 60,000 | 9 | 72,000 | 41.19 | 46.7 |
| 15 – Bitumin/biomass Recycle | 10,000 | 28 | 89,700 | 55.32 | 46.7 |
| 16 – Bitumin/biomass Recycle | 10,000 | 29 | 90,900 | 55.79 | 46.2 |

APPENDIX E: ANALYTICAL APPROACH AND DATABASE

The Overall Framework for the Study

In order to develop estimates of the economic requirements and impacts of the AES initiatives, it was necessary to adopt reasonable project and process cost estimates, to utilize established cost and other parameters associated with actual or similar activities, and then to utilize such estimates in an established econometric input-output model. This is what was done in this study. In this Appendix we describe the approach, database, and models.

The MISI Model

The economic and employment effects of the AES initiatives were estimated using the Management Information Services, Inc. (MISI) input-output model and related databases, built upon and derived from a variety of sources, as described below. A simplified depiction of the MISI model as used in this study is shown in Figure 1.

The model includes elements from the following sources:

- The U.S. Commerce Department's national input-output model
- A modified version of the Commerce Department's regional econometric forecasting model
- A modified version of the Regional Input-Output Modeling System (RIMS) supplemented with the Census Bureau/BLS industry-occupation matrix -- adapted to state and sub-state economies by MISI

The first step involves estimating the direct requirements for the AES initiatives from key supporting industries. For example, construction of a coal liquefaction plant will require hardware and services from one set of suppliers, while development of biomass plants will generate requirements for hardware and services from a very different set. Construction of a coal liquefaction plant will generate large direct requirements in the construction, mining, coal, chemicals, and related industries, whereas the biomass plants will generate large direct requirements in other types of supporting industries.

Figure 1
Use of the MISI Model to Estimate the Economic, Employment,
and Occupational Impacts of the AES initiatives

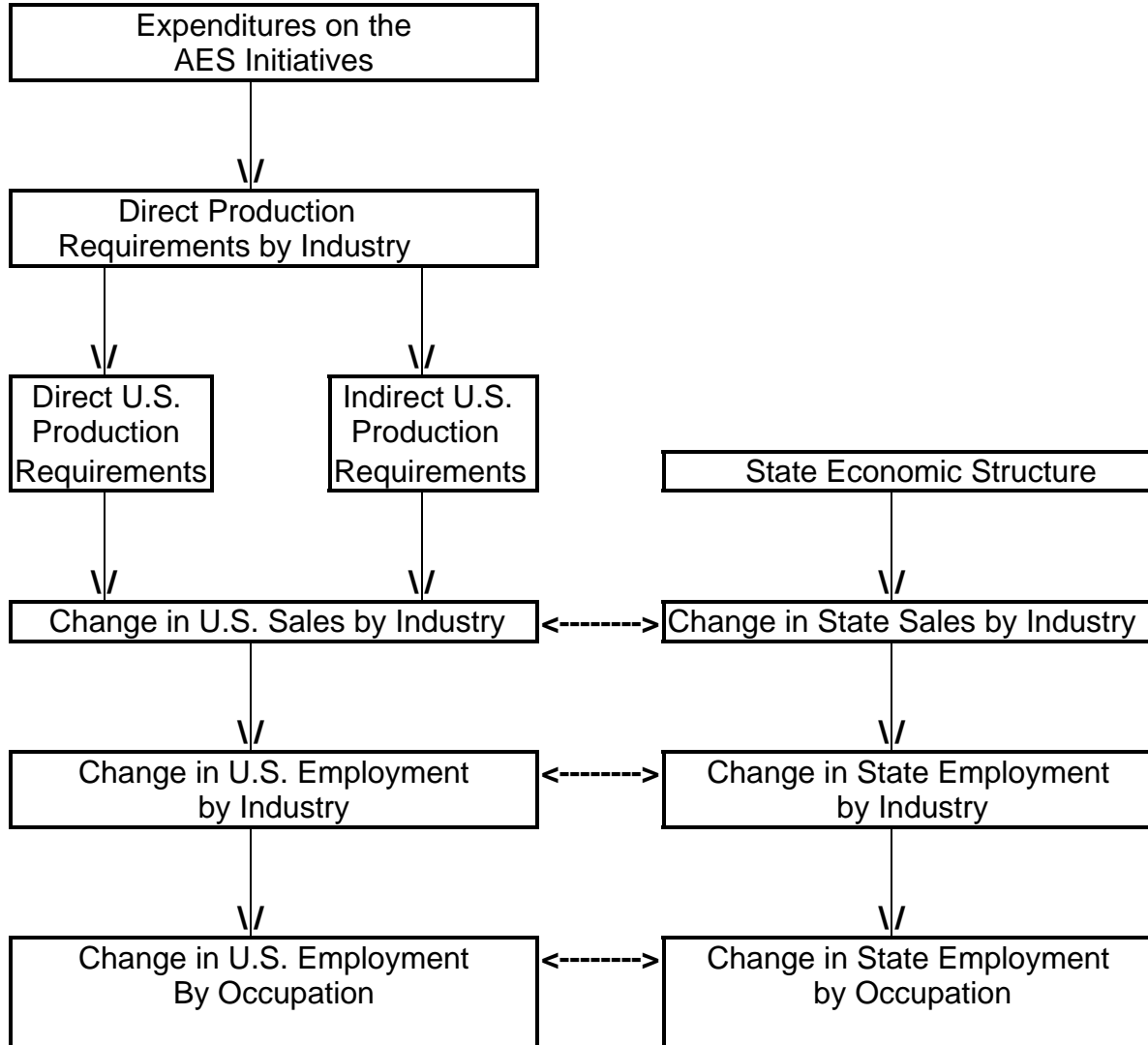

Expenditures for AES initiatives are translated into per unit output requirements from various suppliers. Key determinants include: 1) the specific initiative, 2) the specific expenditure/technology configuration selected, 3) the industry requirements structure, and 4) the distribution of expenditures among suppliers.

Direct output requirements for each supplier are estimated, based on our best judgments of the production and technology requirements for the option. Our judgments are often guided by obvious, open literature specifics and sometimes by analogies, e.g., a CTL plant will have similarities with certain chemical plants. These

direct requirements dictate how much a supplier must purchase from other industries to produce one unit of output.

Direct requirements give rise to subsequent rounds of indirect requirements. For example, a coal liquefaction plant will require steel, and steel mills require electricity to produce steel. But an electric utility requires turbines to produce electricity, and the turbine factory requires steel from steel mills, while steel mills require electricity, etc.

The sum of the direct plus the indirect requirements represents the total output requirements necessary to produce one unit of output for the initiative option. Economic input-output (I-O) techniques allow the computation of the direct as well as the indirect production requirements. These total requirements are represented by the "inverse" equations in the model. The ratio of the total requirements to the direct requirements is called the input-output multiplier.

In the next step in the modeling sequence, the direct industry output requirements are converted into total output requirements by means of the input-output inverse equations. These equations provide not only direct requirements, but also second, third, fourth, and nth round indirect industry and service sector requirements.

The total output requirements from each industry are used to compute sales volumes and value added (including profits and taxes) for each industry. Using data on man-hours, labor requirements, and productivity, employment requirements within each supplier industry are estimated, e.g., the total number of jobs created within an industry.

It is next necessary to convert total employment requirements by industry into job requirements for specific occupations and skills. To accomplish this, data on the occupational composition of the labor force within each industry are used to estimate job requirements for 700 occupations within 22 occupational groups encompassing the entire U.S. labor force. This permits estimation of the impact of the mitigation option on jobs for specific occupations and on skills, education, and training requirements.

Overall, this procedure provides an estimate of the effects on employment, personal income, corporate sales and profits, and government tax revenues in the United States and in each state. Estimates can then be developed for detailed industries and occupations.

Industry Profits

The increase in industry sales generated by the AES initiatives will create substantial profits for the industries involved. However, estimating and forecasting profits by industry is difficult for conceptual and definitional reasons and because industry profits differ widely from year-to-year across different sectors and companies. For example, over the past decade profits per dollar of sales varied by a factor of two in the manufacturing sector, by a factor of five in the mining sector, and by a factor of three in the wholesale trade sector. Even for a given year, profits by company vary greatly

within sectors. For example, within the manufacturing sector profits in the iron and steel industry, the textile mill products industry, and the rubber and plastics products industry are usually in the range of one to three percent of sales, whereas profits in the electrical and electronic equipment industry, the instruments and related products industry, and the chemical products industry are typically in the range of seven to nine percent of sales. Further, even the profit margins within a specific industry differ markedly -- whereas profits in the chemical products industry are in the range of seven to nine percent of sales, within this industry, profits in the drug industry are usually in the range of 14 - 16 percent of sales, but profits in the industrial chemicals industry are usually in the range of five to seven percent of sales.

Thus, to estimate the profits generated by the increased industry sales resulting from the mitigation initiatives the increased sales in each of the 70 NAICS industries requires applying average profit margins in each industry to the increased sales in that industry. Summation of the profits in all industries yields an estimate of total industry profits generated.

Federal, State, and Local Government Tax Revenues

The increased sales and incomes created by the AES initiatives will generate substantial federal, state, and local government tax revenues. Over the past decade, tax revenues for all levels of government have fluctuated between about 29 and 33 percent of income: Federal tax revenues have varied between 19 and 22 percent and combined state and local government taxes (primarily property, income, and sales taxes) have varied between 10 and 11 percent. However, tax revenues as a portion of income differ considerably by state: In some states, such as Connecticut and New York, combined federal-state-local tax revenues total about 33 percent of income, whereas in other states, such as Alabama and South Dakota, combined federal-state-local tax revenues total about 26 percent of income. Accordingly, in estimating the increased tax revenues resulting from the mitigation options we used national averages for both federal and state-local taxes.

Metropolitan Statistical Areas (MSAs)

The final step in the analysis (not carried out in this study) entails assessing the economic impact on specific cities -- Metropolitan Statistical Areas (MSAs). The approach utilized in this work permits disaggregation to the level of most U.S. MSAs and, if desired, to the county level. Empirically, the basis of the sub-state estimates is the MISI version of the Regional Input-Output Modeling System (RIMS II) developed by the U.S. Commerce Department's Bureau of Economic Analysis (BEA).

The MISI model and database permit economic impacts to be estimated for any region composed of one or more counties and for any industry in the national I-O table. MISI can estimate the impacts of project and program expenditures by industry on regional output (gross receipts or sales), earnings (the sum of wages and salaries,

proprietors' income, and other labor income, less employer contributions to private pension and welfare funds), and employment.

For the MSAs there may be further interest in estimating the impact on requirements for specific occupations. This can be accomplished using an occupation-by-industry matrix, the coefficients of which show the percent distribution of occupational employment among all industries. A 500-by-700 matrix was developed from the *Current Population Survey* and was modified to conform to the available data.

The methodology employed has been refined and used by MISI for three decades in a variety of studies of energy and environmental projects, economic initiatives, proposed legislation, government programs, etc.

IV.C. Databases and Data Sources

In the work reported here, the 70-order industry array shown in Table 1 was used.

The databases used in our analysis are derived from a variety of sources including the following:

- The Bureau of Economic Analysis of the U.S. Commerce Department
- The Bureau of the Census of the U.S. Commerce Department
- The Bureau of Labor Statistics of the U.S. Labor Department
- The Energy Information Administration of the U.S. Energy Department
- The U.S. Department of the Treasury

In addition, economic forecasting databases for the U.S. and for most states were utilized. They have been developed and utilized over the past three decades. Using these databases and related experience, the direct and indirect effects of AES initiatives on the national and state economies can be disaggregated into the impacts on:

- Industry sales (490 4-digit NAICS industries)
- Jobs (700 occupations and skills)
- Corporate profits
- Federal, state, and local government tax revenues
- Employment and unemployment (by industry and occupation)
- Net growth or displacement of new businesses
- Major economic, technological, social, and environmental parameters and externalities

Table 1
U.S. Input-Output Industry Codes and Titles, 70-Order

National Industry Codes and Titles by NAICS

| Industry Code | Industry Title | NAICS Code |
|---------------|--|------------|
| 111CA | Farms | 111,112 |
| 113FF | Forestry, fishing, and related activities | 113-115 |
| 211 | Oil and gas extraction | 211 |
| 212 | Mining, except oil and gas | 212 |
| 213 | Support activities for mining | 213 |
| 22 | Utilities | 22 |
| 23 | Construction | 23 |
| 311FT | Food and beverage and tobacco products | 311, 312 |
| 313TT | Textile mills and textile product mills | 313, 314 |
| 315AL | Apparel and leather and allied products | 315, 316 |
| 321 | Wood products | 321 |
| 322 | Paper products | 322 |
| 323 | Printing and related support activities | 323 |
| 324 | Petroleum and coal products | 324 |
| 325 | Chemical products | 325 |
| 326 | Plastics and rubber products | 326 |
| 327 | Nonmetallic mineral products | 327 |
| 331 | Primary metals | 331 |
| 332 | Fabricated metal products | 332 |
| 333 | Machinery | 333 |
| 334 | Computer and electronic products | 334 |
| 335 | Electrical equipment, appliances, and components | 335 |
| 3361MV | Motor vehicles, bodies and trailers, and parts | 3361-3363 |
| 3364OT | Other transportation equipment | 3364-3369 |
| 337 | Furniture and related products | 337 |
| 339 | Miscellaneous manufacturing | 339 |
| 42 | Wholesale trade | 42 |
| 44RT | Retail trade | 44, 45 |
| 481 | Air transportation | 481 |
| 482 | Rail transportation | 482 |
| 483 | Water transportation | 483 |
| 484 | Truck transportation | 484 |
| 485 | Transit and ground passenger transportation | 485 |
| 486 | Pipeline transportation | 486 |
| 487OS | Other transportation and support activities | 487-492 |
| 493 | Warehousing and storage | 493 |

Table IV-1 (continued)
U.S. Input-Output Industry Codes and Titles, 70-Order

| Industry Code | Industry Title | NAICS Code |
|---------------|--|----------------------|
| 511 | Publishing industries (includes software) | 511 |
| 512 | Motion picture and sound recording industries | 512 |
| 513 | Broadcasting and telecommunications | 513 |
| 514 | Information and data processing services | 514 |
| 521CI | Federal Reserve banks, credit intermediation, and related activities | 521, 522 |
| 523 | Securities, commodity contracts, and investments | 523 |
| 524 | Insurance carriers and related activities | 524 |
| 525 | Funds, trusts, and other financial vehicles | 525 |
| 531 | Real estate | 531 |
| 532RL | Rental and leasing services and lessors of intangible assets | 532, 533 |
| 5411 | Legal services | 5411 |
| 5412OP | Miscellaneous professional, scientific and technical services | 5412-5414, 5416-5419 |
| 5415 | Computer systems design and related services | 5415 |
| 55 | Management of companies and enterprises | 55 |
| 561 | Administrative and support services | 561 |
| 562 | Waste management and remediation services | 562 |
| 61 | Educational services | 61 |
| 621 | Ambulatory health care services | 621 |
| 622HO | Hospitals and nursing and residential care facilities | 622, 623 |
| 624 | Social assistance | 624 |
| 711AS | Performing arts, spectator sports, museums, and related activities | 711, 712 |
| 713 | Amusements, gambling, and recreation industries | 713 |
| 721 | Accommodation | 721 |
| 722 | Food services and drinking places | 722 |
| 81 | Other services, except government | 81 |
| GFE | Federal government enterprises | n/a |
| GFG | Federal general government | n/a |
| GSLE | State and local government enterprises | n/a |
| GSLG | State and local general government | n/a |
| S004 | Inventory valuation adjustment | n/a |

Notes: n/a - Not applicable

Source: Management Information Services, Inc. and U.S. Department of Commerce, Bureau of Economic Analysis, 2006.

Appendix F: Fact Sheet: U.S. Oil Shale Economics

DOE Office of Petroleum Reserves

What are the Economic Requirements for Oil Shale Feasibility?

- Oil shale technologies must be demonstrated at commercial scale before definitive capital and operating costs of oil shale projects will be known.
- Oil shale projects must demonstrate capability to achieve a minimum rate of return at expected sustained average world oil prices.

What are the Major Cost Elements of Oil Shale Projects?

For Mining and Surface Retorting:

- Mine development: surface or underground
- Retorting & upgrading facilities: design, manufacture, and construction of facilities
- Infrastructure: roads, pipelines, powerlines, utilities, storage tanks, waste treatment and pollution control.

For In-Situ (underground) Processing:

- Subsurface facilities: wells or shafts to access and heat the shale, recover liquids and gases, and isolate and protect subsurface environments.
- Surface facilities: production pumps and gathering systems, process controls, and upgrading facilities.

How Big is a Commercial Scale Project?

- Commercial oil shale projects could range in size from 10,000 to 50,000 barrels per day for surface retorts to as much as 300,000 barrels per day for full-scale in-situ projects.

How Much Will Commercial Scale Projects Cost?

- Cost estimates will vary according to the oil shale resource and the process selected. In the 1980s, cost estimates for a 100,000 barrel/day surface retort ranged from \$8 - \$12 billion (2005\$)¹.
- Capital costs are expected to be less today, i.e., \$3.0 to \$10.0 billion (2005\$).

Can Costs be Expected to Decrease Over Time?

- Yes. Capital and operating costs can be expected to decrease over time with operating experience, improved understanding, design enhancements, and improved operating efficiencies, analogous to the experience of the Province of Alberta in developing its oil sands resources.

Figure 1. Tar Sand Economics and Production

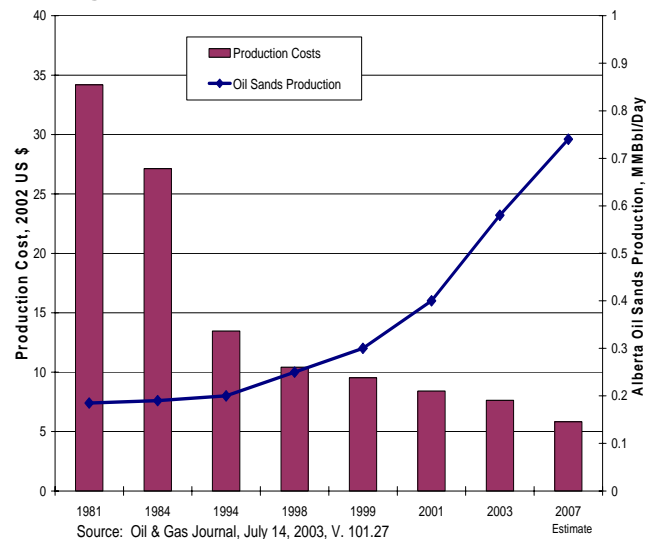

- Production costs in Alberta's tar sands have decreased by as much as 80 percent since the early 1980s. Oil shale cost reductions of 40 to 50 percent could occur as lessons from first of a kind facilities are learned and applied (Figure 1)².
- Mining capital costs have risen with the trend toward more mechanized mining operations. Mine operating costs have decreased significantly as mining efficiency has improved.
- Rapid industry growth may tax limited resources of skilled labor and materials and manufacturing facilities for retorting technologies and mining and processing equipment, increasing costs.

What Sustained Oil Prices are Required for Oil Shale Projects to be Economic?

- First of a kind mining and surface retorting plants may be economic, providing a minimum 15% rate of return, at sustained average world oil prices between \$44 and \$54 per barrel. (Table 1)
- In-situ processes may be economic at sustained average world oil prices above \$30 per barrel.

Table I – Estimated Costs and Minimum Economic Prices for Oil Shale Processes (see pg.2)

| Technology | Number of Tracts | Average Minimum Economic Price (\$/Bbl) | Capital Costs (K\$/SDB) | Operating Costs (\$/Bbl) |
|--------------------|------------------|---|-------------------------|--------------------------|
| Surface Mining | 7 | \$44.24 | \$40 - \$41 | \$12 - \$13 |
| Underground Mining | 7 | \$54.00 | \$41 - \$42 | \$16 - \$17 |
| Modified In-Situ | 7 | \$65.21 | \$27 - \$40 | \$18 - \$26 |
| True In-Situ | 4 | \$37.75 | \$36 - \$56 | \$19 - \$20 |

What are the Potential Public Economic Benefits of Oil Shale Development?

- The Federal treasury, State and local governments, and the overall domestic economy stand to benefit from the direct contributions of a domestic oil shale industry and from the additional economic activity and growth that will result from industry development.
- Direct benefits can be measured in terms of: (1) Direct Federal revenues (from Federal taxes and the Federal share of royalties) (2) Direct state/local revenues (from State and local taxes plus the state share of Federal royalties); (3) Contributions to Gross Domestic Product (GDP) and (4) the value of avoided oil imports.
- At a sustained annual production of about 2.5 million barrels of shale oil per year the cumulative value of these benefits over a 25 year period could exceed \$500 billion.

With Oil Prices at \$60/ Bbl, What are the Impediments to Investment in Oil Shale?

- Large initial capital requirements
- Insufficient private tracts of high-grade oil shale
- Restricted access to resources on public lands
- Oil price uncertainty and volatility
- Technology not demonstrated at commercially-representative scale
- Competing investment opportunities, including investments in other conventional and unconventional oil and gas resources

How Have Current Oil Shale Economics Been Modeled by DOE?

- DOE has performed an analysis of the economics of oil shale. DOE developed a model to evaluate project economics for the application of oil shale technologies to selected resource tracts, and the impacts of various incentives on project economics.
- As there are no commercial facilities currently operating in the United States, capital cost and production cost data used in the analyses were updated from past technology processes and from current vendor cost information to construct plausible cost scenarios.
- The analysis applied resource characterization data from surveys conducted by the U.S. Geological Survey in preparation for the 1974 Prototype Oil Shale Leasing Program. The economic analysis examined 27 USGS defined resource tracts, which were nominated by

industry, to determine the most efficient technology for use at each location.

- The production cost and resource characterization data were then used to calculate minimum economic prices.
- The minimum economic price is defined as the breakeven price assuming a return on capital of 15 percent, and represents our best cost estimates for a mature industry.
- These cost estimates do not take into account research and development costs, permitting costs, land access issues, or production inefficiencies that are characteristic of first-of-a-kind plants. All of these other factors could contribute significantly to early development costs and have the potential to double production costs for the first plants.
- The model estimates cash flow for the various projects by evaluating plant capacity, development schedule, market prices for oil and natural gas, leasing royalty structure, operating costs, capital costs, and tax structure.
- Table 1, presented above, summarizes the model results for the four known extraction technologies. The average minimum economic cost shown in the table below represents the average of the breakeven prices for a given technology across the resource tracts where it is being applied.
- Capital costs are the sum of investments needed per barrel of installed capacity. These costs include investments in mining, retorting, solid waste disposal, refining and upgrading, plant utilities, and other facilities.
- Operating costs include fuel, operating and maintenance personnel, consumable equipment and other non-capital costs for mining, retorting, refining and upgrading.
- The components of both capital and operating costs are different for various technologies used for mining, retorting, and upgrading. These costs were derived from information available from a variety of sources, particularly the Prototype Leasing Program in the early 1980's. These costs were escalated to 2004 dollars using Bureau of Labor Statistics data and were further validated with current vendor quotes.

References

¹ U.S. Office of Technology Assessment. "An Assessment of Oil Shale Technologies", 1980.

² Oil and Gas Journal, July 13, 2003.

APPENDIX G

Biomass Parameters

Pyrolysis Learning Curve

Learning Curve Pyro

$$T_n = T_1 * N^b$$

b = log of learning rate/log 2

NOTE

use .9 for cap costs

use .85 for O&M costs

learning rate 85% @ 200 units

| | | | | |
|----------|--------------|--------------|--------------|--------------|
| b | -0.234465254 | Cap cost | intall cost | total cost |
| T1 cap c | \$ 9,000,000 | \$ 2,583,548 | \$ 1,085,090 | \$ 3,668,638 |

| N | Tn | Cap cost | intall cost | total cost |
|-----|--------------|----------|--------------|------------|
| 1 | \$ 9,000,000 | 555 | \$ 2,045,508 | |
| 5 | \$ 6,171,040 | 565 | \$ 2,036,961 | |
| 15 | \$ 4,769,688 | 575 | \$ 2,028,599 | |
| 25 | \$ 4,231,303 | 585 | \$ 2,020,415 | |
| 35 | \$ 3,910,319 | 595 | \$ 2,012,402 | |
| 45 | \$ 3,686,563 | 605 | \$ 2,004,553 | |
| 55 | \$ 3,517,126 | 615 | \$ 1,996,863 | |
| 65 | \$ 3,382,029 | 625 | \$ 1,989,325 | |
| 75 | \$ 3,270,437 | 635 | \$ 1,981,935 | |
| 85 | \$ 3,175,856 | 645 | \$ 1,974,688 | |
| 95 | \$ 3,094,105 | 655 | \$ 1,967,577 | |
| 105 | \$ 3,022,344 | 665 | \$ 1,960,600 | |
| 115 | \$ 2,958,561 | 675 | \$ 1,953,750 | |
| 125 | \$ 2,901,282 | 685 | \$ 1,947,025 | |
| 135 | \$ 2,849,399 | 695 | \$ 1,940,420 | |
| 145 | \$ 2,802,056 | 705 | \$ 1,933,932 | |
| 155 | \$ 2,758,582 | 715 | \$ 1,927,556 | |
| 165 | \$ 2,718,439 | 725 | \$ 1,921,289 | |
| 175 | \$ 2,681,193 | 735 | \$ 1,915,128 | |
| 185 | \$ 2,646,485 | 745 | \$ 1,909,069 | |
| 195 | \$ 2,614,020 | 755 | \$ 1,903,110 | |
| 205 | \$ 2,583,548 | 765 | \$ 1,897,248 | |
| 215 | \$ 2,554,858 | 775 | \$ 1,891,480 | |
| 225 | \$ 2,527,769 | 785 | \$ 1,885,802 | |
| 235 | \$ 2,502,128 | 795 | \$ 1,880,214 | |
| 245 | \$ 2,477,799 | 805 | \$ 1,874,711 | |
| 255 | \$ 2,454,666 | 815 | \$ 1,869,292 | |
| 265 | \$ 2,432,627 | 825 | \$ 1,863,955 | |
| 275 | \$ 2,411,592 | 835 | \$ 1,858,697 | |
| 285 | \$ 2,391,480 | 845 | \$ 1,853,516 | |
| 295 | \$ 2,372,221 | 855 | \$ 1,848,410 | |
| 305 | \$ 2,353,751 | 865 | \$ 1,843,378 | |
| 315 | \$ 2,336,014 | 875 | \$ 1,838,416 | |
| 325 | \$ 2,318,959 | 885 | \$ 1,833,524 | |
| 335 | \$ 2,302,540 | 895 | \$ 1,828,700 | |
| 345 | \$ 2,286,715 | 905 | \$ 1,823,943 | |
| 355 | \$ 2,271,447 | 915 | \$ 1,819,249 | |
| 365 | \$ 2,256,700 | 925 | \$ 1,814,619 | |
| 375 | \$ 2,242,444 | 935 | \$ 1,810,049 | |
| 385 | \$ 2,228,650 | 945 | \$ 1,805,540 | |
| 395 | \$ 2,215,291 | 955 | \$ 1,801,089 | |
| 405 | \$ 2,202,343 | 965 | \$ 1,796,696 | |
| 415 | \$ 2,189,784 | 975 | \$ 1,792,358 | |
| 425 | \$ 2,177,593 | 985 | \$ 1,788,075 | |
| 435 | \$ 2,165,751 | 995 | \$ 1,783,845 | |
| 445 | \$ 2,154,240 | 1005 | \$ 1,779,668 | |
| 455 | \$ 2,143,045 | 1015 | \$ 1,775,541 | |
| 465 | \$ 2,132,149 | 1025 | \$ 1,771,464 | |
| 475 | \$ 2,121,538 | 1035 | \$ 1,767,436 | |
| 485 | \$ 2,111,200 | 1045 | \$ 1,763,456 | |
| 495 | \$ 2,101,122 | 1055 | \$ 1,759,523 | |
| 505 | \$ 2,091,292 | 1065 | \$ 1,755,635 | |
| 515 | \$ 2,081,699 | 1075 | \$ 1,751,792 | |
| 525 | \$ 2,072,334 | 1085 | \$ 1,747,993 | |
| 535 | \$ 2,063,186 | 1095 | \$ 1,744,237 | |
| 545 | \$ 2,054,247 | | | |

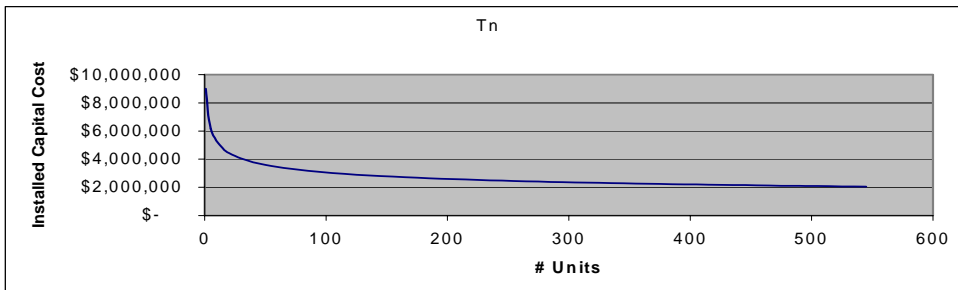

Pyrolysis

| Table 1 | | Dynamotive | | Renewable Oil International | |
|---------------------------------------|-------------------------|------------|---|-----------------------------|-----------|
| Category | Units | Value | Comment | Units | Value |
| Capacity | dry tons/day | 121.3 | Dynamotive-Numbers from a 200 wet ton/day plant (220.402 wet ton/day). | dry tons/day | 150 |
| Construction Period | Months | 6-12 | 65% IAC | Months | 6-12 |
| Capital Cost | US \$ | 8,900,000 | include start up commissioning | US \$ | 2,782,500 |
| Labor | # Personnel | 14 | installed cost or purchase cost? | # Personnel | 10 |
| Variable Costs | | | | | |
| Feedstock | \$/bbl | 30.00 | dependent on site location, feedstock source | \$/bbl | 30.00 |
| Utilities | \$/year | 691,686 | Electricity, Natural Gas, Water (excludes nitrogen and miscellaneous chemicals) | \$/year | 187,000 |
| Royalties | % of gross revenue | 3-10% | | % of gross revenue | 3-10% |
| Capital Replacement | % of capital costs/year | 2% | | % of capital costs/year | 2% |
| Energy input/yard (Btu in vs Btu out) | Mtu/Btu/day | 1,705 | | Mtu/Btu/day | 2,254 |

To put them both on 150tpd scale is all I can do is raise each category in dynamotive by 19%

0.191639333

| Table 2 | | Dynamotive | | Renewable Oil International | |
|---------------------------------------|-------------------------|------------|--|-----------------------------|-----------|
| Category | Units | Value | Comment | Units | Value |
| Capacity | dry tons/day | 150.0 | Dynamotive-Numbers from a 200 wet ton/day plant (220.402 wet ton/day). | dry tons/day | 150 |
| Construction Period | Months | 6-12 | 65% IAC | Months | 6-12 |
| Capital Cost | US \$ | 10,486,428 | include start up commissioning | US \$ | 2,782,500 |
| Labor | # Personnel | 17 | 16.88295067 | # Personnel | 10 |
| Variable Costs | | | | | |
| Feedstock | \$/bbl | 30.00 | dependent on site location, feedstock source | \$/bbl | 30.00 |
| Utilities | \$/year | 824,216 | Electricity, Natural Gas, Water | \$/year | 187,000 |
| Royalties | % of gross revenue | 3-10% | | % of gross revenue | 3-10% |
| Capital Replacement | % of capital costs/year | 2% | | % of capital costs/year | 2% |
| Energy input/yard (Btu in vs Btu out) | Mtu/Btu/day | 1,378 | | Mtu/Btu/day | 2,254 |

Source for Dynamotive: Technical, Environmental and Economic Feasibility of BioOil in New Hampshire's North Country

Numbers provided below are scaled up versions from Table 2, above 150 dtpd to 500 dtpd.

| Table 3 | | Dynamotive | | Renewable Oil International | |
|---------------------------------------|-------------------------|------------|--|-----------------------------|-----------|
| Category | Units | Value | Comment | Units | Value |
| Capacity | dry tons/day | 500.0 | scaled by .3 from 150 dtpd | dry tons/day | 500 |
| Construction Period | Months | 12 to 18 | include start up commissioning | Months | 12 to 18 |
| Capital Cost | US \$ | 33,632,354 | installed cost or purchase cost? | US \$ | 3,630,250 |
| Labor | # Personnel | 22 | 22.1 | # Personnel | 13 |
| Variable Costs | | | | | |
| Feedstock | \$/bbl | 30.00 | dependent on site location, feedstock source | \$/bbl | 30.00 |
| Utilities | \$/year | 1,071,481 | Electricity, Natural Gas, Water | \$/year | 374,000 |
| Royalties | % of gross revenue | 3-10% | | % of gross revenue | 3-10% |
| Capital Replacement | % of capital costs/year | 2% | | % of capital costs/year | 2% |
| Energy input/yard (Btu in vs Btu out) | Mtu/Btu/day | 7,455 | | Mtu/Btu/day | 7,597 |

| Dynamotive, Energy Input yield calculation | |
|---|--|
| Btu in/Btu out | |
| 8500 | Btu/dry lb (av. Of hardwood and softwood) |
| 121.3 | dry tons/day (feed stock processed), Dynamotive |
| 78,779,526 | Btu/day, ((962 kWh)/operating hour), Electricity |
| 346.75 | days of operation per year |
| 71,440,487 | Btu of Natural Gas/day(75374 MJ/day) |
| 24 | hours/day |
| $\frac{8500 \text{ btu}}{1 \text{ dry lb}} \times \frac{2000 \text{ lb}}{1 \text{ ton}} \times \frac{121.3 \text{ tons}}{1 \text{ day}} = \frac{2,061,319,700 \text{ btu}}{\text{day}} \quad \text{going in}$ | |
| Assuming only Btu loss is through energy used in process for Electricity and Natural Gas and plant is 90% efficient | |
| 1,855,187,730 | Btu in / day |
| - | 150,220,013 Btu used for energy / day |
| = | 1,704,967,717 Net Btu's/day |
| = | 1,705 Mmbtu/day |

| Renewable Oil International , Energy Input yield calculation | |
|---|---|
| Btu in/Btu out | |
| 8500 | Btu/dry lb (av. Of hardwood and softwood) |
| 150.0 | dry tons/day (feed stock processed) |
| 21,270,472 | Btu/day, based on a percentage from Dynamotive, \$ /Electric to \$/capital cost |
| 346.75 | days of operation per year |
| 19,288,932 | Btu of Natural Gas/day(75374 MJ) |
| 24 | hours/day |
| $\frac{8500 \text{ btu}}{1 \text{ dry lb}} \times \frac{2000 \text{ lb}}{1 \text{ ton}} \times \frac{150.0 \text{ tons}}{1 \text{ day}} = \frac{2,550,000,000 \text{ btu}}{\text{day}} \quad \text{going in}$ | |
| Assuming only Btu loss is through energy used in process for Electricity and Natural Gas and plant is 90% efficient | |
| 2,295,000,000 | Btu in / day |
| - | 40,559,404 Btu used for energy / day |
| = | 2,254,440,596 Net Btu's/day |
| = | 2,254 Mmbtu/day |

| Dynamotive, Energy Input yield calculation | |
|---|--|
| Btu in/Btu out | |
| 8500 | Btu/dry lb (av. Of hardwood and softwood) |
| 500.0 | dry tons/day (feed stock processed), Dynamotive |
| 102,413,384 | Btu/day, ((962 kWh)/operating hour), Electricity |
| 346.75 | days of operation per year |
| 92,872,633 | Btu of Natural Gas/day(75374 MJ/day) |
| 24 | hours/day |
| $\frac{8500 \text{ btu}}{1 \text{ dry lb}} \times \frac{2000 \text{ lb}}{1 \text{ ton}} \times \frac{500.0 \text{ tons}}{1 \text{ day}} = \frac{8,500,000,000 \text{ btu}}{\text{day}} \quad \text{going in}$ | |
| Assuming only Btu loss is through energy used in process for Electricity and Natural Gas and plant is 90% efficient | |
| 7,650,000,000 | Btu in / day |
| - | 195,286,017 Btu used for energy / day |
| = | 7,454,713,983 Net Btu's/day |
| = | 7,455 Mmbtu/day |

| Renewable Oil International , Energy Input yield calculation | |
|---|---|
| Btu in/Btu out | |
| 8500 | Btu/dry lb (av. Of hardwood and softwood) |
| 500.0 | dry tons/day (feed stock processed) |
| 27,651,614 | Btu/day, based on a percentage from Dynamotive, \$ /Electric to \$/capital cost |
| 346.75 | days of operation per year |
| 25,075,611 | Btu of Natural Gas/day(75374 MJ) |
| 24 | hours/day |
| $\frac{8500 \text{ btu}}{1 \text{ dry lb}} \times \frac{2000 \text{ lb}}{1 \text{ ton}} \times \frac{500.0 \text{ tons}}{1 \text{ day}} = \frac{8,500,000,000 \text{ btu}}{\text{day}} \quad \text{going in}$ | |
| Assuming only Btu loss is through energy used in process for Electricity and Natural Gas and plant is 90% efficient | |
| 7,650,000,000 | Btu in / day |
| - | 52,727,225 Btu used for energy / day |
| = | 7,597,272,775 Net Btu's/day |
| = | 7,597 Mmbtu/day |

Cellulose Ethanol

| Units | Value | Adj Value | Reference | Comment |
|-------------------|-----------|-----------|-------------------|---|
| dry tons per day | 3,000 | | | |
| Months | 24 | | | |
| Million \$ | \$ 113.7 | \$ 123.4 | NREL/TP-510-32438 | Include start up commissioning |
| Million \$ | \$ 83.7 | \$ 90.9 | | installed 2002\$, needs to be scaled to 2006, see chemical engineering purchased equip. index |
| Million \$ | \$ 197.4 | \$ 214.3 | | |
| Million \$/year | \$ 12.7 | \$ 13.8 | | |
| Million \$/year | \$ 2.0 | \$ 2.2 | | 0.424012158 |
| Million \$/year | \$ 7.5 | \$ 8.1 | | |
| Million \$/year | \$ 22.2 | \$ 24.1 | | |
| # Personnel | 70-80 | | NREL/TP-510-32438 | |
| \$ Personnel (MM) | \$ 1.80 | | NREL/TP-510-32438 | Fully loaded |
| \$/bdt | \$ 30.00 | | NREL/TP-510-32438 | 2002\$, needs to be scaled to 2006, see inorganic chemical index |
| \$/year (credit) | \$ (6.05) | | NREL/TP-510-32438 | Electricity, water |
| \$MM/yr | \$ 14.20 | | NREL/TP-510-32438 | |
| | \$ 9.94 | | | |

Gasification Learning Curve

Learning Curve

Gas

$$T_n = T_1 \cdot N^b$$

b = log of learning rate/log 2

NOTE

use .9 for cap costs

use .85 for O&M costs

learning rate

85% @ 200 units

b

-0.234465254

Cap cost

intall cost

total cost

T1 cap cost

\$ 26,000,000

\$ 7,463,583

\$ 2,686,890

\$ 10,150,473

N

Tn

| | | | |
|-----|---------------|------|--------------|
| 1 | \$ 26,000,000 | 545 | \$ 5,934,491 |
| 5 | \$ 17,827,448 | 555 | \$ 5,909,245 |
| 15 | \$ 13,779,099 | 565 | \$ 5,884,555 |
| 25 | \$ 12,223,765 | 575 | \$ 5,860,398 |
| 35 | \$ 11,296,478 | 585 | \$ 5,836,755 |
| 45 | \$ 10,650,070 | 595 | \$ 5,813,605 |
| 55 | \$ 10,160,586 | 605 | \$ 5,790,931 |
| 65 | \$ 9,770,306 | 615 | \$ 5,768,714 |
| 75 | \$ 9,447,929 | 625 | \$ 5,746,940 |
| 85 | \$ 9,174,695 | 635 | \$ 5,725,591 |
| 95 | \$ 8,938,525 | 645 | \$ 5,704,653 |
| 105 | \$ 8,731,215 | 655 | \$ 5,684,112 |
| 115 | \$ 8,546,953 | 665 | \$ 5,663,954 |
| 125 | \$ 8,381,482 | 675 | \$ 5,644,168 |
| 135 | \$ 8,231,597 | 685 | \$ 5,624,740 |
| 145 | \$ 8,094,828 | 695 | \$ 5,605,659 |
| 155 | \$ 7,969,236 | 705 | \$ 5,586,914 |
| 165 | \$ 7,853,268 | 715 | \$ 5,568,494 |
| 175 | \$ 7,745,668 | 725 | \$ 5,550,390 |
| 185 | \$ 7,645,402 | 735 | \$ 5,532,591 |
| 195 | \$ 7,551,614 | 745 | \$ 5,515,089 |
| 205 | \$ 7,463,583 | 755 | \$ 5,497,874 |
| 215 | \$ 7,380,700 | 765 | \$ 5,480,939 |
| 225 | \$ 7,302,445 | 775 | \$ 5,464,274 |
| 235 | \$ 7,228,369 | 785 | \$ 5,447,873 |
| 245 | \$ 7,158,086 | 795 | \$ 5,431,728 |
| 255 | \$ 7,091,258 | 805 | \$ 5,415,832 |
| 265 | \$ 7,027,590 | 815 | \$ 5,400,178 |
| 275 | \$ 6,966,820 | 825 | \$ 5,384,759 |
| 285 | \$ 6,908,719 | 835 | \$ 5,369,569 |
| 295 | \$ 6,853,082 | 845 | \$ 5,354,601 |
| 305 | \$ 6,799,725 | 855 | \$ 5,339,851 |
| 315 | \$ 6,748,486 | 865 | \$ 5,325,313 |
| 325 | \$ 6,699,216 | 875 | \$ 5,310,980 |
| 335 | \$ 6,651,783 | 885 | \$ 5,296,848 |
| 345 | \$ 6,606,067 | 895 | \$ 5,282,912 |
| 355 | \$ 6,561,957 | 905 | \$ 5,269,167 |
| 365 | \$ 6,519,356 | 915 | \$ 5,255,608 |
| 375 | \$ 6,478,172 | 925 | \$ 5,242,231 |
| 385 | \$ 6,438,321 | 935 | \$ 5,229,031 |
| 395 | \$ 6,399,729 | 945 | \$ 5,216,005 |
| 405 | \$ 6,362,323 | 955 | \$ 5,203,147 |
| 415 | \$ 6,326,042 | 965 | \$ 5,190,455 |
| 425 | \$ 6,290,823 | 975 | \$ 5,177,923 |
| 435 | \$ 6,256,613 | 985 | \$ 5,165,550 |
| 445 | \$ 6,223,360 | 995 | \$ 5,153,331 |
| 455 | \$ 6,191,018 | 1005 | \$ 5,141,262 |
| 465 | \$ 6,159,540 | 1015 | \$ 5,129,340 |
| 475 | \$ 6,128,888 | 1025 | \$ 5,117,563 |
| 485 | \$ 6,099,022 | 1035 | \$ 5,105,927 |
| 495 | \$ 6,069,907 | 1045 | \$ 5,094,429 |
| 505 | \$ 6,041,509 | 1055 | \$ 5,083,065 |
| 515 | \$ 6,013,797 | 1065 | \$ 5,071,834 |
| 525 | \$ 5,986,742 | 1075 | \$ 5,060,733 |
| 535 | \$ 5,960,315 | 1085 | \$ 5,049,758 |
| | | 1095 | \$ 5,038,907 |

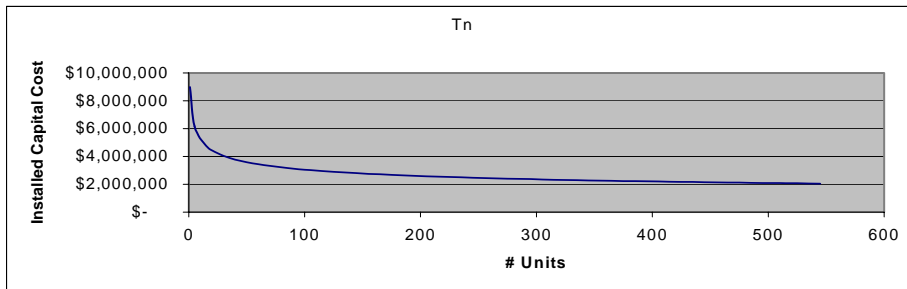

Gasification

| Category | Units | Value | Scale | Reference | Comment |
|------------------------------|------------------|---------|----------|-----------|---------|
| Capacity | dry tons per day | 100 | 1,000 | | |
| Construction Period | Months | 18 | | | |
| Equipment Cost | Million \$ | \$ 9.5 | \$ 94.6 | | |
| Installation Cost | Million \$ | \$ 5.3 | \$ 53.0 | | |
| Total Project Investment | Million \$ | \$ 14.8 | \$ 147.5 | 36% | |
| Non-Feedstock Operating Exp. | Million \$/year | \$ 1.3 | \$ 12.5 | | |
| Waste Disposal | Million \$/year | \$ - | \$ - | | |
| Fixed Cost | Million \$/year | \$ 1.4 | \$ 13.6 | | |
| | | \$ - | \$ - | | |
| Total O&M | Million \$/year | \$ 2.6 | \$ 26.1 | | |

| Category | 100 dtpd | | % |
|-----------------------------------|---------------|--|-----|
| Engineered equipment | \$ 9,455,000 | | 64% |
| Bulk commodities and construction | \$ 1,645,093 | | 11% |
| Labor and other costs | \$ 781,643 | | 5% |
| Other costs | \$ 2,870,238 | | 19% |
| Total | \$ 14,751,973 | | |

| | |
|----------|-----------------|
| Debt | \$ 660,420.72 |
| Fixed | \$ 147,627.24 |
| Fuel | \$ 1,764,048.00 |
| Payroll | \$ 563,530.07 |
| Variable | \$ 541,745.23 |

NREL Data on Gasification

| Raw Material | kg/hr | cost (\$/lb) | | MM\$/yr |
|-------------------------|-----------|--------------|----|--------------|
| Clarifier Polymer | 28.0 | \$ 1.2500 | \$ | 0.64 |
| Sulfuric Acid | 3,288.0 | \$ 0.0124 | \$ | 0.75 |
| Lime | 2,395.0 | \$ 0.0348 | \$ | 1.53 |
| Corn Steep Liquor | 1,306.0 | \$ 0.0804 | \$ | 1.92 |
| Purchased Cellulase | 6,824.0 | \$ 0.0552 | \$ | 6.90 |
| Diammonimu Phosphate | 163.0 | \$ 0.0706 | \$ | 0.21 |
| Propane | 20.0 | \$ 0.0022 | \$ | 0.00 |
| BFW Chemicals | 1.0 | \$ 1.3497 | \$ | 0.02 |
| Cooling Water Chemicals | 1.9 | \$ 1.0204 | \$ | 0.04 |
| WWT Chemicals | 57.9 | \$ 0.1579 | \$ | 0.17 |
| WWT Polymer | 0.2 | \$ 2.5510 | \$ | 0.01 |
| Ash Disposal | 4,492.0 | \$ 0.0094 | \$ | 0.77 |
| Gypsum Disposal | 7,217.0 | \$ 0.0094 | \$ | 1.24 |
| Subtotal | | | \$ | 14.20 |
| | | | \$ | - |
| Utilities | | | \$ | - |
| Make-up Water | 186,649.0 | \$ 0.0001 | \$ | 0.34 |
| Electricity (credit) | 18,747.0 | \$ 0.0410 | \$ | 6 |

Biofuels Yields

IOGEN

$$\frac{1,235,000,000 \text{ dry tons}}{\text{year}} \times \frac{90 \text{ gal EtOH}}{\text{dry ton}} = \frac{1.1115 \times 10^{11} \text{ gal EtOH}}{\text{yr}} \times \frac{80,000 \text{ Btu}}{\text{gal EtOH}} \times \frac{\text{bbl oil}}{5,825,000 \text{ Btu}} = 1.53 \times 10^9 \text{ BOE}$$

ROI Fast Pyrolysis

$$\frac{1,235,000,000 \text{ dry tons}}{\text{year}} \times \frac{120 \text{ gal BO}}{\text{dry ton}} = \frac{1.482 \times 10^{11} \text{ gal BO}}{\text{yr}} \times \frac{80,000 \text{ Btu}}{\text{gal BO}} \times \frac{\text{bbl oil}}{5,825,000 \text{ Btu}} = 2.04 \times 10^9 \text{ BOE}$$

Fischer-Tropsch (Based on Choren)

$$\frac{1,235,000,000 \text{ dry tons}}{\text{year}} \times \frac{59.7 \text{ gal Biofuel}}{\text{dry ton}} = \frac{73688846832 \text{ gal Biofuel}}{\text{yr}} \times \frac{\text{assumed } 130,000 \text{ Btu}}{\text{gal BF}} \times \frac{\text{bbl oil}}{5,825,005 \text{ Btu}} = 1.64 \times 10^9 \text{ BOE}$$

According to the Choren Website at <http://www.choren.com/en/faq/>

$$\frac{1.7 \text{ t BF}}{\text{hr}} = \frac{16,500,000 \text{ Liters BF}}{\text{yr}} = \frac{67,000 \text{ dt biomass}}{\text{yr}} \quad \text{where BF = biofuels}$$

$$\text{then } \frac{16,500,000 \text{ Liters BF}}{\text{yr}} \times \frac{\text{yr}}{340 \text{ day}} \times \frac{\text{day}}{24 \text{ hr}} \times \frac{\text{hr}}{1.7 \text{ t BF}} = \frac{1,189 \text{ L BF}}{\text{tonne BF}}$$

$$\frac{\text{tonne BF}}{1,189 \text{ L BF}} \times \frac{3.75 \text{ L BF}}{\text{gal BF}} \times \frac{2200 \text{ lb BF}}{\text{tonne BF}} = \frac{6.94 \text{ lb BF}}{\text{gal BF}}$$

$$\text{and } \frac{1.7 \text{ t BF}}{\text{hr}} \times \frac{24 \text{ hr}}{\text{day}} \times \frac{\text{day}}{\text{yr}} = \frac{13,872 \text{ t BF}}{\text{yr}}$$

$$\text{then } \frac{13,872 \text{ t BF/yr}}{67,000 \text{ dt BM/yr}} = \frac{0.21 \text{ ton BF}}{\text{dt BM}}$$

$$\frac{0.21 \text{ ton BF}}{\text{dt BM}} \times \frac{2000 \text{ lb BF}}{\text{ton BF}} \times \frac{\text{gal BF}}{6.94 \text{ lb BF}} = \frac{59.7 \text{ gal BF}}{\text{dt ton BM}}$$

Summary

Product - Total MM BOE/d

| | Cellulosic | Gas. & F-T | Pyrolysis | Total |
|------|------------|------------|-----------|-------------|
| 2005 | 0.00 | 0.00 | 0.00 | 0.00 |
| 2006 | 0.00 | 0.00 | 0.00 | 0.00 |
| 2007 | 0.00 | 0.00 | 0.00 | 0.00 |
| 2008 | 0.00 | 0.00 | 0.02 | 0.02 |
| 2009 | 0.00 | 0.01 | 0.04 | 0.04 |
| 2010 | 0.00 | 0.01 | 0.06 | 0.08 |
| 2011 | 0.01 | 0.02 | 0.07 | 0.11 |
| 2012 | 0.03 | 0.02 | 0.09 | 0.14 |
| 2013 | 0.05 | 0.03 | 0.10 | 0.18 |
| 2014 | 0.07 | 0.03 | 0.12 | 0.22 |
| 2015 | 0.10 | 0.04 | 0.14 | 0.28 |
| 2016 | 0.13 | 0.05 | 0.16 | 0.34 |
| 2017 | 0.16 | 0.07 | 0.18 | 0.41 |
| 2018 | 0.20 | 0.08 | 0.21 | 0.49 |
| 2019 | 0.24 | 0.11 | 0.24 | 0.59 |
| 2020 | 0.29 | 0.13 | 0.28 | 0.70 |
| 2021 | 0.34 | 0.16 | 0.33 | 0.84 |
| 2022 | 0.40 | 0.21 | 0.38 | 0.99 |
| 2023 | 0.48 | 0.26 | 0.44 | 1.18 |
| 2024 | 0.56 | 0.32 | 0.51 | 1.39 |
| 2025 | 0.65 | 0.40 | 0.60 | 1.65 |
| 2026 | 0.76 | 0.50 | 0.69 | 1.95 |
| 2027 | 0.88 | 0.63 | 0.80 | 2.31 |
| 2028 | 1.01 | 0.79 | 0.93 | 2.73 |
| 2029 | 1.17 | 0.98 | 1.08 | 3.24 |
| 2030 | 1.35 | 1.23 | 1.25 | 3.83 |
| % | 35% | 32% | 33% | |

Cellulosic Gas. & F-T Pyrolysis
1.35 1.23 1.25

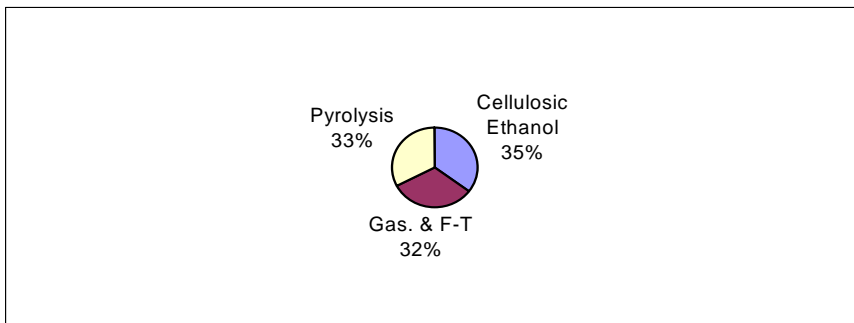
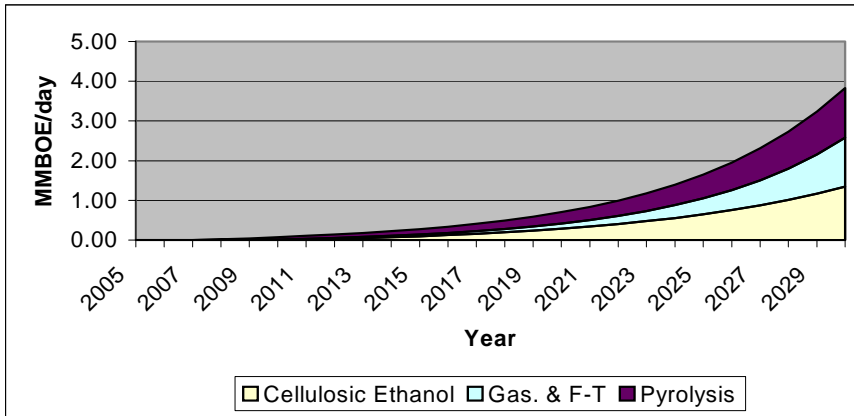

Pyrolysis

Annual Growth rate 16.0%
 BOE/d/plant (500) 927 3,832.52
 1000 1,854
 1500 2,781

| Year | Facilities | | | Total #/yr | Cumulative total | Total MM BOE/d |
|------|------------|------------|------------|------------|------------------|----------------|
| | 500 tpd # | 1000 tpd # | 1500 tpd # | | | |
| 2005 | | | | - | | |
| 2006 | | | | - | | |
| 2007 | | | | - | | |
| 2008 | 20 | | | 20 | 20 | 0.02 |
| 2009 | 23 | 8 | | 31 | 51 | 0.04 |
| 2010 | 27 | 9 | 8 | 44 | 75 | 0.06 |
| 2011 | 31 | 11 | 9 | 51 | 95 | 0.07 |
| 2012 | 36 | 12 | 11 | 59 | 111 | 0.09 |
| 2013 | 42 | 14 | 12 | 69 | 128 | 0.10 |
| 2014 | 49 | 17 | 14 | 80 | 149 | 0.12 |
| 2015 | 57 | 19 | 17 | 93 | 173 | 0.14 |
| 2016 | 66 | 23 | 19 | 108 | 200 | 0.16 |
| 2017 | 76 | 26 | 23 | 125 | 233 | 0.18 |
| 2018 | 88 | 30 | 26 | 145 | 270 | 0.21 |
| 2019 | 102 | 35 | 30 | 168 | 313 | 0.24 |
| 2020 | 119 | 41 | 35 | 195 | 363 | 0.28 |
| 2021 | 138 | 47 | 41 | 226 | 421 | 0.33 |
| 2022 | 160 | 55 | 47 | 262 | 488 | 0.38 |
| 2023 | 185 | 64 | 55 | 304 | 567 | 0.44 |
| 2024 | 215 | 74 | 64 | 353 | 657 | 0.51 |
| 2025 | 249 | 86 | 74 | 409 | 762 | 0.60 |
| 2026 | 289 | 100 | 86 | 475 | 884 | 0.69 |
| 2027 | 336 | 116 | 100 | 551 | 1,026 | 0.80 |
| 2028 | 389 | 134 | 116 | 639 | 1,190 | 0.93 |
| 2029 | 451 | 156 | 134 | 741 | 1,381 | 1.08 |
| 2030 | 524 | 181 | 156 | 860 | 1,601 | 1.25 |

Pyrolysis & Gas-FT

Pyrolysis and gasification FT (assume balance not supplied by EFC to be split 50/50 between pyrolysis and Gas/FT)
 EFC will supply 9%, therefore pyrolysis and gas-FT will supply 91%, or 3.5E6 BOE/day by 2030 starting in 2008 (22 years)
 or one technology would supply 1.73 E6 BOE/day by 2030 starting in 2008 (22 years)
 thus the technology would have to average 78,636 BOE/day/yr in growth
 assume an average plant size of 500 dt/day for pyrolysis, use 80 gal/dt to account for upgrading losses

Assume for pyrolysis that we get 140 gal BF/dt at 80,000 Btu/gal
 after upgrading we would have 135,000 Btu/gal with 80 gal BF/dt yield

For pyrolysis?

| | | | | | | | | |
|-----------|---|-----------|---|------------|---|---------------|---|-----|
| 500 dt | X | 80 gal BF | X | 135000 Btu | X | bbl oil | = | 927 |
| day-plant | | dt | | gal BF | | 5,825,005 Btu | | |

which is equivalent to an average of 85 new plants /yr

for a year = 305,922 BOE/yr/plant

75,217 BOE/day/yr
 81 new BO plants/yr

For FT

| | | | | | | | | |
|-----------|---|-----------|---|------------|---|---------------|---|-----|
| 500 dt | X | 65 gal BF | X | 135000 Btu | X | bbl oil | = | 753 |
| day-plant | | dt | | gal BF | | 5,825,005 Btu | | |

which is equivalent to an average of 104 new plants /yr

for a year = 248,562 BOE/yr/plant

75,217 BOE/day/yr
 100 new BO plants/yr

| Category | Units | Value | Reference | Source |
|--------------------------------------|----------------|------------|-------------|--------|
| Existing capacity | Billion gal/yr | | | |
| Under construction capacity | Billion gal/yr | | | |
| Total capacity, 2007 | Billion gal/yr | - | calculation | |
| Total capacity, 2007 | gallons/year | - | calculation | |
| Barrel conversion (crude oil) | gallon/bbl | 42 | | |
| Energy content, pyrolysis oil | Btu/gallon | 135,000 | | |
| Energy content, #2 oil | Btu/bbl | 5,825,005 | | |
| Ethanol barrel of oil equivalent | gallons | 43 | calculation | |
| Barrel of Oil equivalent | BOE/yr | - | calculation | |
| Barrel of Oil equivalent | BOE/d | - | calculation | |
| New capacity | gallons/yr | | | |
| Est. # of plants @ 15 million/gal ea | # | 0 | | |
| Avg plant capacity | gallons/yr | 14,600,000 | nominal | |
| Capacity factor | % | 80% | | |
| Plant production (average) | gal/d | 32,000 | | |
| Plant production (average) | BOE/d | 742 | | |
| Annual Growth rate | %/yr | 5% | | |
| 15 million gal/yr plant capacity | BOE/d | 742 | | |
| Possible limit to EFC | gallons/yr | 7,00E+09 | | |
| Limit | BOE/d | 444,470 | | |
| Limit | MMBOE/d | 0.44 | | |

| Category | Units | Value | Reference | Source |
|--------------------------------------|----------------|------------|-------------|--------|
| Existing capacity | Billion gal/yr | | | |
| Under construction capacity | Billion gal/yr | | | |
| Total capacity, 2007 | Billion gal/yr | - | calculation | |
| Total capacity, 2007 | gallons/year | - | calculation | |
| Barrel conversion (crude oil) | gallon/bbl | 42 | | |
| Energy content, FT oil | Btu/gallon | 135,000 | | |
| Energy content, #2 oil | Btu/bbl | 5,825,005 | | |
| Ethanol barrel of oil equivalent | gallons | 43 | calculation | |
| Barrel of Oil equivalent | BOE/yr | - | calculation | |
| Barrel of Oil equivalent | BOE/d | - | calculation | |
| New capacity | gallons/yr | | | |
| Est. # of plants @ 12 million/gal ea | # | 0 | | |
| Avg plant capacity | gallons/yr | 11,862,500 | nominal | |
| Capacity factor | % | 80% | | |
| Plant production (average) | gal/d | 26,000 | | |
| Plant production (average) | BOE/d | 603 | | |
| Annual Growth rate | %/yr | 5% | | |
| 12 million gal/yr plant capacity | BOE/d | 603 | | |
| Possible limit to EFC | gallons/yr | 7,00E+09 | | |
| Limit | BOE/d | 444,470 | | |
| Limit | MMBOE/d | 0.44 | | |

| Year | 15,000,000 gal/day | Cumulative total | Total MM BOE/d | % of limit |
|------|--------------------|------------------|----------------|------------|
| 2005 | | | | |
| 2006 | | | | |
| 2007 | | | | |
| 2008 | 5 | 5 | 0.00 | 0% |
| 2009 | 5 | 10 | 0.01 | 0% |
| 2010 | 5 | 15 | 0.01 | 0% |
| 2011 | 5 | 20 | 0.01 | 0% |
| 2012 | 5 | 25 | 0.02 | 0% |
| 2013 | 5 | 30 | 0.02 | 0% |
| 2014 | 5 | 35 | 0.03 | 0% |
| 2015 | 5 | 40 | 0.03 | 0% |
| 2016 | 5 | 45 | 0.03 | 0% |
| 2017 | 5 | 50 | 0.04 | 0% |
| 2018 | 5 | 55 | 0.04 | 0% |
| 2019 | 5 | 60 | 0.04 | 0% |
| 2020 | 5 | 65 | 0.05 | 0% |
| 2021 | 5 | 70 | 0.05 | 0% |
| 2022 | 5 | 75 | 0.06 | 0% |
| 2023 | 5 | 80 | 0.06 | 0% |
| 2024 | 5 | 85 | 0.06 | 0% |
| 2025 | 5 | 90 | 0.07 | 0% |
| 2026 | 5 | 95 | 0.07 | 0% |
| 2027 | 5 | 100 | 0.07 | 0% |
| 2028 | 5 | 105 | 0.08 | 0% |
| 2029 | 5 | 110 | 0.08 | 0% |

| Year | 12,000,000 gal/day | Cumulative total | Total MM BOE/d | % of limit |
|------|--------------------|------------------|----------------|------------|
| 2005 | | | | |
| 2006 | | | | |
| 2007 | | | | |
| 2008 | 5 | 5 | 0.00 | 0% |
| 2009 | 5 | 10 | 0.01 | 0% |
| 2010 | 5 | 15 | 0.01 | 0% |
| 2011 | 5 | 20 | 0.01 | 0% |
| 2012 | 5 | 25 | 0.02 | 0% |
| 2013 | 5 | 30 | 0.02 | 0% |
| 2014 | 5 | 35 | 0.02 | 0% |
| 2015 | 5 | 40 | 0.02 | 0% |
| 2016 | 5 | 45 | 0.03 | 0% |
| 2017 | 5 | 50 | 0.03 | 0% |
| 2018 | 5 | 55 | 0.03 | 0% |
| 2019 | 5 | 60 | 0.04 | 0% |
| 2020 | 5 | 65 | 0.04 | 0% |
| 2021 | 5 | 70 | 0.04 | 0% |
| 2022 | 5 | 75 | 0.05 | 0% |
| 2023 | 5 | 80 | 0.05 | 0% |
| 2024 | 5 | 85 | 0.05 | 0% |
| 2025 | 5 | 90 | 0.05 | 0% |
| 2026 | 5 | 95 | 0.06 | 0% |
| 2027 | 5 | 100 | 0.06 | 0% |
| 2028 | 5 | 105 | 0.06 | 0% |
| 2029 | 5 | 110 | 0.07 | 0% |

Gas FT Growth

| | | | |
|--------------------|-------|----------|--|
| Annual Growth rate | 25% | | |
| BOE/d/plant (500) | 753 | 3,832.52 | |
| 1000 | 1,506 | | |
| 1500 | 2,260 | | |

| Year | Facilities | | | | Cumulative total | Total MM BOE/d |
|------|------------|------------|------------|------------|------------------|----------------|
| | 500 tpd # | 1000 tpd # | 1500 tpd # | Total #/yr | | |
| 2005 | | | | - | | |
| 2006 | | | | - | | |
| 2007 | | | | - | | |
| 2008 | 5 | | | 5 | 5 | 0.0 |
| 2009 | 6 | 2 | | 8 | 13 | 0.0 |
| 2010 | 8 | 3 | 2 | 12 | 21 | 0.0 |
| 2011 | 10 | 3 | 3 | 15 | 28 | 0.0 |
| 2012 | 12 | 4 | 3 | 19 | 35 | 0.0 |
| 2013 | 15 | 5 | 4 | 24 | 43 | 0.0 |
| 2014 | 19 | 6 | 5 | 30 | 54 | 0.0 |
| 2015 | 24 | 8 | 6 | 38 | 68 | 0.0 |
| 2016 | 30 | 10 | 8 | 47 | 85 | 0.1 |
| 2017 | 37 | 12 | 10 | 59 | 106 | 0.1 |
| 2018 | 47 | 15 | 12 | 73 | 132 | 0.1 |
| 2019 | 58 | 19 | 15 | 92 | 165 | 0.1 |
| 2020 | 73 | 23 | 19 | 115 | 206 | 0.1 |
| 2021 | 91 | 29 | 23 | 143 | 258 | 0.2 |
| 2022 | 114 | 36 | 29 | 179 | 323 | 0.2 |
| 2023 | 142 | 45 | 36 | 224 | 403 | 0.3 |
| 2024 | 178 | 57 | 45 | 280 | 504 | 0.3 |
| 2025 | 222 | 71 | 57 | 350 | 630 | 0.4 |
| 2026 | 278 | 89 | 71 | 437 | 787 | 0.5 |
| 2027 | 347 | 111 | 89 | 547 | 984 | 0.6 |
| 2028 | 434 | 139 | 111 | 683 | 1,230 | 0.8 |
| 2029 | 542 | 173 | 139 | 854 | 1,538 | 1.0 |
| 2030 | 678 | 217 | 173 | 1,068 | 1,922 | 1.2 |

EFC

| | | | | |
|--|---|--|--|---|
| $\frac{3000 \text{ dry ton}}{\text{day/plant}} \times$ | $\frac{90 \text{ gal}}{\text{dry ton}} \times$ | $\frac{\text{Btu}}{\text{gal}} \times$ | $\frac{\text{bbl oil}}{\text{\# Btu}} =$ | $\frac{\# \text{ BOE}}{\text{day/EFC plant}}$ |
| we need 3.8 E6 BOE/day by 2030 starting in 2012 (18 years) | | | | |
| if all growth came from EFC, then we would have to average | | | | |
| | | 211,111 | BOE/day/yr in growth | |
| which is equivalent to an average of | | | | |
| | 57 | new plants /yr | | |
| However, this growth will be a ramp up. | | | | |
| DOE EIA assumes that by 2020 we will be producing 2.8 E9 gal ETOH/yr from EFC using the Hi Tech growth curve | | | | |
| $\frac{2,800,000,000 \text{ gal ETOH}}{\text{yr}} \times$ | $\frac{80,000 \text{ Btu}}{\text{gal ETOH}} \times$ | $\frac{\text{bbl oil}}{\# \text{ Btu}} =$ | $\frac{\# \text{ BOE}}{\text{yr}} =$ | $\# \text{ BOE/day}$ |
| Extrapolating to 2030, DOE EIA projects we will be producing 8 E9 gal EFC/yr using the hi tech growth curve | | | | |
| $\frac{8,000,000,000 \text{ gal ETOH}}{\text{yr}} \times$ | $\frac{80,000 \text{ Btu}}{\text{gal ETOH}} \times$ | $\frac{\text{bbl oil}}{\# \text{ Btu}} =$ | $\frac{\# \text{ BOE}}{\text{yr}} =$ | $\# \text{ BOE/day}$ |
| | | | | $\frac{\# \# \text{ of daily production}}{\text{day/yr}}$ |
| | $\frac{80,000 \text{ Btu}}{\text{gal ETOH}} \times$ | $\frac{\text{bbl oil}}{\# \text{ Btu}} \times$ | $\frac{\text{yr}}{\# \# \text{ day}} =$ | $\frac{0 \text{ BOE/gal ETOH}}{\text{day/yr}}$ |

| Category | Units | Value | Reference | Source |
|---------------------------------------|----------------|------------|-------------|----------|
| Existing capacity | Billion gal/yr | | | |
| Under construction capacity | Billion gal/yr | | | |
| Total capacity, 2007 | Billion gal/yr | - | calculation | |
| Total capacity, 2007 | gallons/year | - | calculation | |
| Barrel conversion (crude oil) | gallon/bbl | 42 | | |
| Energy content, ethanol | Btu/gallon | 80,000 | | |
| Energy content, #2 oil | Btu/bbl | 5,825,005 | | |
| Ethanol barrel of oil equivalent | gallons | 73 | calculation | |
| Barrel of Oil equivalent | BOE/yr | - | calculation | |
| Barrel of Oil equivalent | BOE/d | - | calculation | |
| New capacity | gallons/yr | | | |
| Est. # of plants @ 100 million/gal ea | # | 0 | | |
| Avg plant capacity | dtpy | 3000 | | |
| Avg plant capacity | gallons/yr | 98,550,000 | nominal | |
| Capacity factor | % | 80% | | |
| Plant production (average) | gal/d | 216,000 | | |
| Plant production (average) | BOE/d | 2,967 | | |
| Annual Growth rate | %/yr | 14.0% | | 3,832.52 |
| 100 million gal/yr plant capacity | BOE/d | 2,967 | | |
| Possible limit to EFC | gallons/yr | | | |
| Limit | BOE/d | 0 | | |
| Limit | MMBOE/d | - | | |

| Year | 100,000,000 gal/day | Cumulative total | Total MM BOE/d | % limit |
|------|---------------------|------------------|----------------|---------|
| 2005 | | | | |
| 2006 | | | | |
| 2007 | - | - | - | |
| 2008 | - | - | - | |
| 2009 | - | - | - | |
| 2010 | - | - | - | |
| 2011 | 5 | 5 | 0.01 | |
| 2012 | 6 | 11 | 0.03 | |
| 2013 | 6 | 17 | 0.05 | |
| 2014 | 7 | 25 | 0.07 | |
| 2015 | 8 | 33 | 0.10 | |
| 2016 | 10 | 43 | 0.13 | |
| 2017 | 11 | 54 | 0.16 | |
| 2018 | 13 | 66 | 0.20 | |
| 2019 | 14 | 80 | 0.24 | |
| 2020 | 16 | 97 | 0.29 | |
| 2021 | 19 | 115 | 0.34 | |
| 2022 | 21 | 136 | 0.40 | |
| 2023 | 24 | 160 | 0.48 | |
| 2024 | 27 | 188 | 0.56 | |
| 2025 | 31 | 219 | 0.65 | |
| 2026 | 36 | 255 | 0.76 | |
| 2027 | 41 | 296 | 0.88 | |
| 2028 | 46 | 342 | 1.01 | |
| 2029 | 53 | 395 | 1.17 | |
| 2030 | 60 | 455 | 1.35 | 406% |

332,943 boe/d

DOE EFC Curve

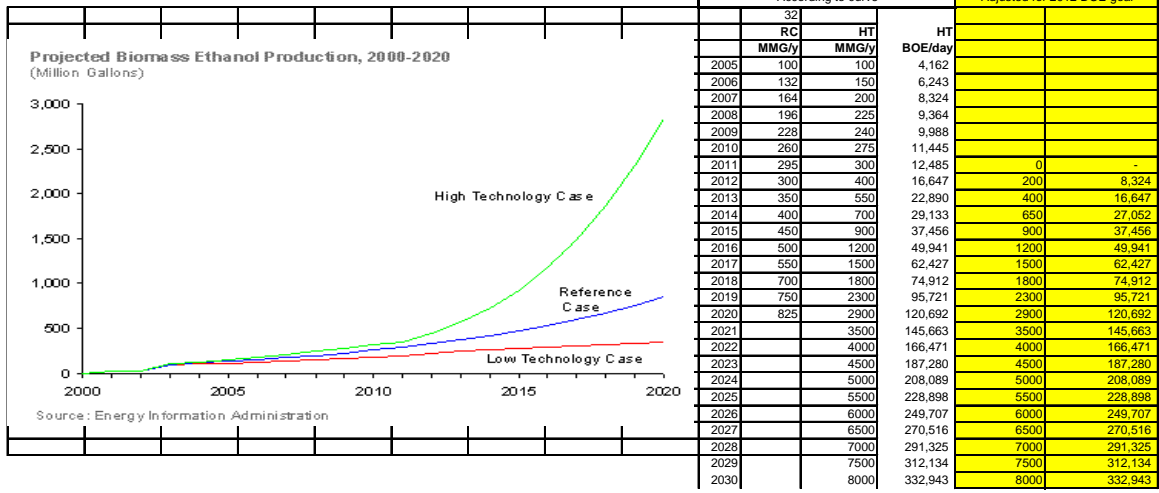

Conversion factor =

4.1618E-05 BOE/gal ETOH
day/yr

Corn Ethanol

| Category | Units | Value | Reference | Source |
|--------------------------------------|----------------|---------------|-------------|----------------------|
| Existing capacity | Billion gal/yr | 4.4 | | 97 plants |
| Under construction capacity | Billion gal/yr | 2.1 | | 4.30E+09 gallons |
| Total capacity, 2007 | Billion gal/yr | 6.5 | calculation | 44,329,897 gal/plant |
| Total capacity, 2007 | gallons/year | 6,500,000,000 | calculation | |
| Barrel conversion (crude oil) | gallon/bbl | 42 | | |
| Energy content, ethanol | Btu/gallon | 80,000 | | |
| Energy content, #2 oil | Btu/bbl | 5,825,005 | | |
| Ethanol barrel of oil equivalent | gallons | 73 | calculation | |
| Barrel of Oil equivalent | BOE/yr | 89,270,310 | calculation | |
| Barrel of Oil equivalent | BOE/d | 244,576 | calculation | |
| New capacity | gallons/yr | 2,100,000,000 | | |
| Est. # of plants @ 50 million/gal ea | # | 42 | | |
| Avg plant capacity | gallons/yr | 50,000,000 | | |
| Capacity factor | % | 80% | | |
| Plant production (average) | gal/d | 109,589 | | |
| Plant production (average) | BOE/d | 1,505 | | |
| Annual Growth rate | %/yr | 10% | | |
| 50 million gal/yr plant capacity | BOE/d | 1,505 | | |
| Possible limit to corn ethanol | gallons/yr | 7.00E+09 | | |
| Limit | BOE/d | 263,390 | | |
| Limit | MMBOE/d | 0.26 | | |

| Year | 50,000,000 gal/day | Cumulative total | Total MM BOE/d | % of limit |
|------|--------------------|------------------|----------------|------------|
| 2005 | | | | |
| 2006 | | | | |
| 2007 | | 139 | 0.21 | 79% |
| 2008 | 5 | 144 | 0.22 | 82% |
| 2009 | 6 | 150 | 0.23 | 86% |
| 2010 | 7 | 157 | 0.24 | 90% |
| 2011 | 8 | 165 | 0.25 | 94% |
| 2012 | 9 | 174 | 0.26 | 99% |
| 2013 | 10 | 184 | 0.28 | 105% |
| 2014 | 11 | 195 | 0.29 | 111% |
| 2015 | 12 | 207 | 0.31 | 118% |
| 2016 | 13 | 220 | 0.33 | 126% |
| 2017 | 14 | 234 | 0.35 | 134% |
| 2018 | 15 | 249 | 0.37 | 142% |
| 2019 | 17 | 266 | 0.40 | 152% |
| 2020 | 19 | 285 | 0.43 | 163% |
| 2021 | 21 | 306 | 0.46 | 175% |
| 2022 | 23 | 329 | 0.50 | 188% |
| 2023 | 25 | 354 | 0.53 | 202% |
| 2024 | 28 | 382 | 0.57 | 218% |
| 2025 | 31 | 413 | 0.62 | 236% |
| 2026 | 34 | 447 | 0.67 | 255% |
| 2027 | 37 | 484 | 0.73 | 277% |
| 2028 | 41 | 525 | 0.79 | 300% |
| 2029 | 45 | 570 | 0.86 | 326% |
| 2030 | 50 | 620 | 0.93 | 354% |

| Year | Ethanol Produced | Grain Used |
|----------------|----------------------|----------------------|
| 1997 | 1.3 billion gallons | 500 million bushels |
| 1998 | 1.4 billion gallons | 538 million bushels |
| 1999 | 1.47 billion gallons | 565 million bushels |
| 2000 | 1.63 billion gallons | 627 million bushels |
| 2001 | 1.77 billion gallons | 681 million bushels |
| 2002 | 2.13 billion gallons | 819 million bushels |
| 2003 | 2.81 billion gallons | |
| 2004 | 3.4 billion gallons | 1.22 billion bushels |
| 2005 | 3.9 billion gallons | 1.4 billion bushels |
| As of May 2006 | 4.5 billion gallons | 1.6 billion bushels |

The US ethanol industry is the fastest growing energy industry in the world.
Ethanol is blended in 30% of our nation's gasoline.
An annual record of 3.4 billion gallons of ethanol was produced in 2004.
As of May 5, 2006, the US had 97 plants in operation and with a capacity of 4.5 billion gallons per year. 35 additional plants are currently under construction and nine existing plants are in expansion. The plants under construction will add over 2.2 billion gallons of annual production capacity.

<http://www.ksgains.com/ethanol/useeth.html>
US ETHANOL FACTS

The Ethanol Industry Outlook can be found on the RFA webpage at:
http://www.ethanolrfa.org/objects/pdf/outlook/outlook_2006.pdf

Biodiesel

| Category | Units | Value | Reference | Source |
|------------------------------------|----------------|---------------|-------------|---|
| Existing capacity | million gal/yr | 395 | NBB | http://www.biodiesel.org/pdf_files/fuelsheets/Production_Capacity.pdf |
| Under construction capacity | million gal/yr | 714 | NBB | http://www.biodiesel.org/pdf_files/fuelsheets/Production_Capacity.pdf |
| Total capacity, 2007 | million gal/yr | 1,109 | calculation | |
| Total capacity, 2007 | gallons/year | 1,109,000,000 | calculation | |
| Barrel conversion | gallon/bbl | 42 | | |
| Energy content, biodiesel | Btu/gallon | 118,296 | NBB | http://www.biodiesel.org/pdf_files/fuelsheets/BTU_Content_Final_Oct2005.pdf |
| Energy content, #2 | Btu/bbl | 5,825,005 | crude oil | |
| Biodiesel barrel of oil equivalent | gallons | 49.2 | calculation | |
| Barrel of Oil equivalent | BOE/yr | 22,521,914 | calculation | |
| Barrel of Oil equivalent | BOE/d | 61,704 | | |

| | | | |
|----------------------------------|------------|-------------|---------------------|
| New capacity | gallons/yr | 713,700,000 | All plants combined |
| # of Plants | # | 58 | |
| Avg plant capacity | gallons/yr | 12,305,172 | |
| Capacity factor | % | 80% | |
| Plant production | gal/d | 26,970 | |
| Plant production | BOE/d | 548 | |
| Annual Growth rate | %/yr | 10% | |
| 50 million gal/yr plant capacity | BOE/d | 548 | |
| Possible limit to biodiesel | gallons/yr | 1.00E+09 | this is a guess |
| Limit | BOE/d | 55,639 | |
| Limit | MMBOE/d | 0.06 | |

| Year | # of Plants | Cumulative total | Total MM BOE/d | % of limit |
|------|-------------|------------------|----------------|------------|
| 2005 | | | | 62,987.80 |
| 2006 | | | | |
| 2007 | 115 | 115 | 0.06 | 113% |
| 2008 | 15 | 130 | 0.07 | 128% |
| 2009 | 17 | 147 | 0.08 | 145% |
| 2010 | 19 | 166 | 0.09 | 163% |
| 2011 | 21 | 187 | 0.10 | 184% |
| 2012 | 23 | 210 | 0.12 | 207% |
| 2013 | 25 | 235 | 0.13 | 231% |
| 2014 | 28 | 263 | 0.14 | 259% |
| 2015 | 31 | 294 | 0.16 | 289% |
| 2016 | 34 | 328 | 0.18 | 323% |
| 2017 | 37 | 365 | 0.20 | 359% |
| 2018 | 41 | 406 | 0.22 | 400% |
| 2019 | 45 | 451 | 0.25 | 444% |
| 2020 | 50 | 501 | 0.27 | 493% |
| 2021 | 55 | 556 | 0.30 | 547% |
| 2022 | 61 | 617 | 0.34 | 607% |
| 2023 | 67 | 684 | 0.37 | 673% |
| 2024 | 74 | 758 | 0.42 | 746% |
| 2025 | 81 | 839 | 0.46 | 826% |
| 2026 | 89 | 928 | 0.51 | 914% |
| 2027 | 98 | 1,026 | 0.56 | 1010% |
| 2028 | 108 | 1,134 | 0.62 | 1116% |
| 2029 | 119 | 1,253 | 0.69 | 1233% |
| 2030 | 131 | 1,384 | 0.76 | 1362% |